

ICs for CD/CD-ROM Player

**Panasonic**

# AN8807SB

## Three-Beam Method Head Amplifier IC for CD-ROM

### ■ Overview

The AN8807SB is a head amplifier IC supporting the digital servo.

Combination of this IC and the MN662710RA (digital servo processor + signal processing + DAC/DF) allows the rational CD ROM system to be constructed with small number of external parts.

### ■ Features

- Single supply operation
- I-V amplifier, tracking error amplifier, focus error amplifier, RF amplifier and APC built-in
- Detectors of DO, CROSS, OFTR and vibration built-in
- Combination with the MN662710RA providing complete automatic adjustment for tracking balance, tracking gain, tracking offset, focus balance, focus gain and focus offset

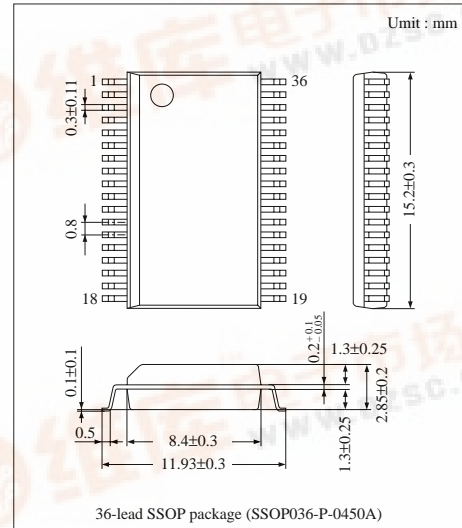

■ Block Diagram

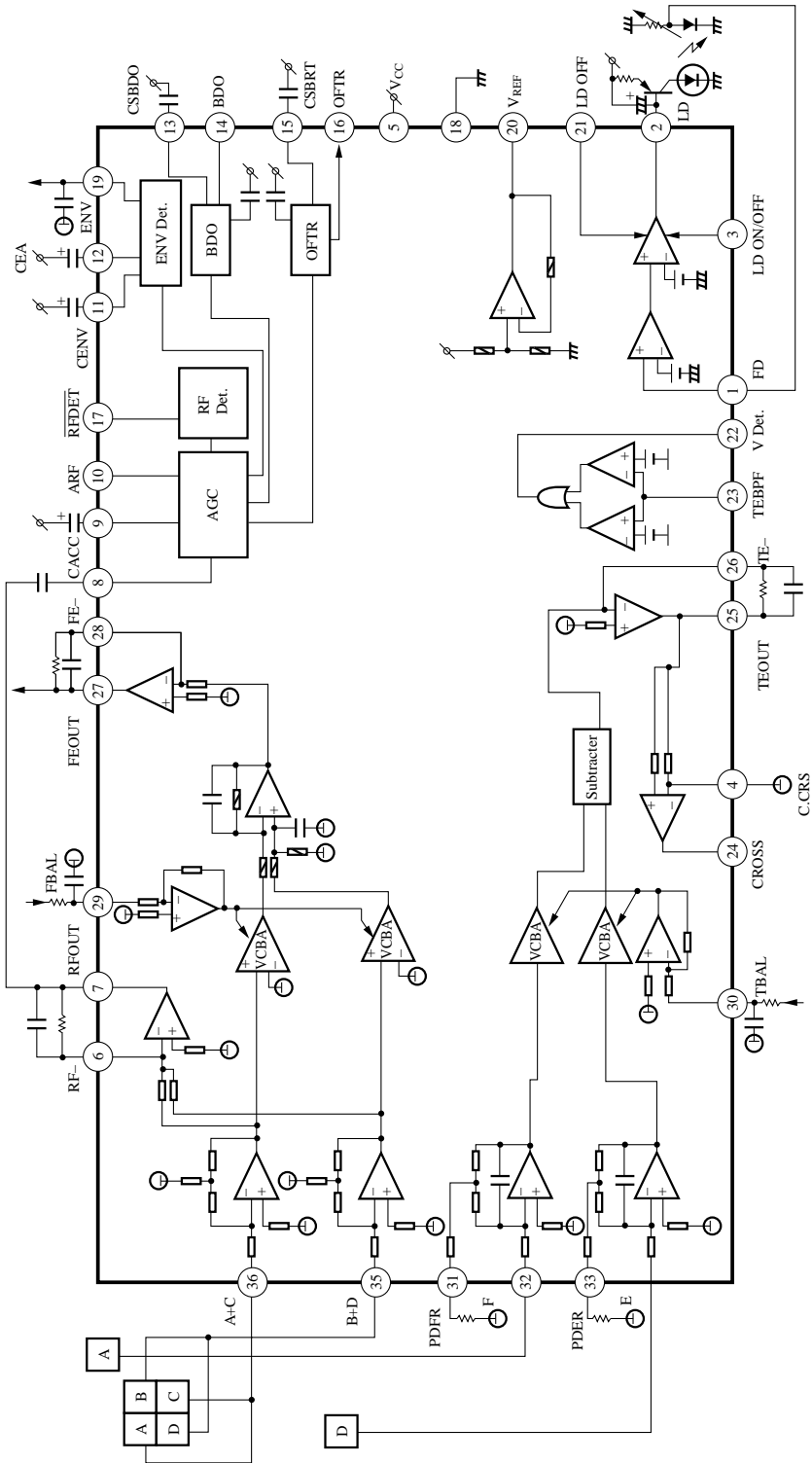

### ■ Pin Description

Pin No.	Pin Name	I/O	Function Description
1	P <sub>D</sub>	I	Signal input of P <sub>D</sub> for LD output monitor
2	LD	O	Connected to base of external Tr for LD drive
3	LDON	I	ON/OFF switching of LD APC
4	C. CRS	—	Capacity connecting pin for CROSS
5	V <sub>CC</sub>	—	Supply connecting pin
6	RF-	I	Reverse rotation input pin of RF Amp. for connecting a resistance
7	RFOUT	O	Output pin of RF Amp. (reverse rotation amp.)
8	RFIN	I	RF AGC input pin
9	C. AGC	—	C-connecting pin for RF AGC loop filter
10	ARF	O	RF output pin after AGC
11	C. ENV	—	C-connecting pin for RF
12	C. EA	—	C-connecting pin for amp.
13	C. SBDO	—	C-connecting pin for low speed detection of dark level DO
14	BDO	O	BDO detection output pin; positive logic
15	C. SBRT	—	C-connecting pin for OFTR low speed detection
16	OFTR	O	OFF TRACK detection output pin; positive logic
17	NRFDET	O	Output pin of RF signal amplitude detection; negative logic
18	GND	—	Ground pin
19	ENV	O	ENV output pin
20	V <sub>REF</sub>	O	V <sub>CC</sub> × 0.5 (V) output pin
21	LD OFF	I	Input pin for forced stop of LD APC
22	VDET	O	Output pin of vibration detection
23	TEBPF	I	Input pin of vibration detection
24	CROSS	O	Output pin of TE CROSS detection signal
25	TEOUT	O	Output pin of TE Amp.
26	TE-	I	Inverting input pin of TE Amp. for connecting a resistance
27	FEOUT	O	Output pin of FE Amp.
28	FE-	I	Inverting input pin of FE Amp. for connecting a resistance
29	FBAL	I	Control signal input pin for FO balance adjustment
30	TBAL	I	Control signal input pin for TE balance adjustment
31	PDFR	—	Resistance-connected pin setting the I-V conversion resistance value of PDE
32	PDER	—	Resistance-connected pin setting the I-V conversion resistance value of PDF
33	PDE	I	Connected to PIN Diode E
34	PDF	I	Connected to PIN Diode F
35	PDBD	I	Connected to B/D of astigmatic 4-division P <sub>D</sub>
36	PDAC	I	Connected to A/C of astigmatic 4-division P <sub>D</sub>

### ■ Absolute Maximum Ratings (Ta=25°C)

Parameter	Symbol	Rating	Unit
Supply Voltage	V <sub>CC</sub>	6	V
Supply Current	I <sub>CC</sub>	40	mA
Power Dissipation	P <sub>D</sub>	240	mW
Operating Ambient Temperature	T <sub>opr</sub>	-20 ~ +75	°C
Storage Temperature	T <sub>stg</sub>	-55 ~ +125	°C

### ■ Recommended Operating Range (Ta=25°C)

Parameter	Symbol	Range
Operating Supply Voltage Range	V <sub>CC</sub>	3.4V ~ 5.5V

### ■ Electrical Characteristics (Ta=25°C±2°C)

Parameter	Symbol	Condition	min.	typ.	max.	Unit
Total Circuit Current	I <sub>tot</sub>	V <sub>CC</sub> =5V	10.0	14.5	19.0	mA
V <sub>REF</sub> Output Voltage	V <sub>REF</sub>	V <sub>CC</sub> =5V	2.20	2.50	2.80	V

#### Focus Error Amp.

Output Offset Voltage of Focus Error Amp.	V <sub>FO-OF</sub>	V <sub>CC</sub> =5V	-300	0	300	mV
Crosstalk Quantity of Focus Error Offset Balance	V <sub>FO-OFB</sub>	V <sub>CC</sub> =5V, V <sub>FB</sub> =V <sub>REF</sub> ±1V Applied	-200	—	200	mV
I-V Conversion Gain of Focus Error Amp.	R <sub>FO</sub>	V <sub>CC</sub> =5V, V <sub>FB</sub> =V <sub>REF</sub>	65	93	121	kΩ
I-V Conversion Relative Gain of Focus Error Amp.	DR <sub>FO</sub>	V <sub>CC</sub> =5V, V <sub>FB</sub> =V <sub>REF</sub>	-12	0	12	%
Focus Balance Variable Range 1-H	B <sub>FO1-H</sub>	V <sub>CC</sub> =5V, V <sub>FB</sub> =V <sub>REF</sub> +1V	0.15	0.25	0.35	—
Focus Balance Variable Range 1-L	B <sub>FO1-L</sub>	V <sub>CC</sub> =5V, V <sub>FB</sub> =V <sub>REF</sub> -1V	1.19	1.70	2.21	—
Focus Balance Variable Range 2-H	B <sub>FO2-H</sub>	V <sub>CC</sub> =5V, V <sub>FB</sub> =V <sub>REF</sub> +1V	1.19	1.70	2.21	—
Focus Balance Variable Range 2-L	B <sub>FO2-L</sub>	V <sub>CC</sub> =5V, V <sub>FB</sub> =V <sub>REF</sub> -1V	0.15	0.25	0.35	—
Frequency Characteristics of Focus Error Amp.	G <sub>FO</sub>	V <sub>CC</sub> =5V, f=1kHz, 30kHz Input	-4.5	-3	-1.5	dB

#### Tracking Error Amp.

Output Offset Voltage of Tracking Error Amp.	V <sub>TR-OF</sub>	V <sub>CC</sub> =5V	-63	0	63	mV
Crosstalk Quantity of Tracking Error Offset Balance	V <sub>TR-OFB</sub>	V <sub>CC</sub> =5V, V <sub>TB</sub> =V <sub>REF</sub> ±1V Applied	-200	—	200	mV
I-V Conversion Gain of Tracking Error Amp.	R <sub>TR</sub>	V <sub>CC</sub> =5V, V <sub>TB</sub> =V <sub>REF</sub>	420	600	780	kΩ
I-V Conversion Relative Gain of Tracking Error Amp.	DR <sub>TR</sub>	V <sub>CC</sub> =5V, V <sub>TB</sub> =V <sub>REF</sub>	-15	0	15	%
Tracking Balance Variable Range 1-H	B <sub>TR1-H</sub>	V <sub>CC</sub> =5V, V <sub>TB</sub> =V <sub>REF</sub> +1V	0.185	0.285	0.385	—
Tracking Balance Variable Range 1-L	B <sub>TR1-L</sub>	V <sub>CC</sub> =5V, V <sub>TB</sub> =V <sub>REF</sub> -1V	1.20	1.75	2.30	—
Tracking Balance Variable Range 2-H	B <sub>TR2-H</sub>	V <sub>CC</sub> =5V, V <sub>TB</sub> =V <sub>REF</sub> +1V	1.20	1.75	2.30	—
Tracking Balance Variable Range 2-L	B <sub>TR2-L</sub>	V <sub>CC</sub> =5V, V <sub>TB</sub> =V <sub>REF</sub> -1V	0.175	0.275	0.375	—
Frequency Characteristics of Tracking Error Amp.	G <sub>TR</sub>	V <sub>CC</sub> =5V, f=10kHz, 100kHz	-3.8	-2.3	-0.8	dB

#### CROSS Detection

CROSS Output H Level	V <sub>CR-H</sub>	V <sub>CC</sub> =5V, V <sub>TB</sub> =V <sub>REF</sub> f=10kHz	4.2	—	—	V
CROSS Output L Level	V <sub>CR-L</sub>	V <sub>CC</sub> =5V, V <sub>TB</sub> =V <sub>REF</sub> f=10kHz	—	—	0.8	V

#### RF-Amp.

RF-Amp. Offset Voltage	V <sub>RF-OF</sub>	V <sub>CC</sub> =5V	-75	0	75	mV
RF-Amp. I-V Conversion Gain	R <sub>RF</sub>	V <sub>CC</sub> =5V	45.0	56.5	68.0	kΩ
RF-Amp. I-V Conversion Relative Gain 1	DR <sub>RF</sub>	V <sub>CC</sub> =5V	-10	0	10	%
RF-Amp. Frequency Characteristics 1 <sup>Note)</sup>	G <sub>RF</sub>	V <sub>CC</sub> =5V, f=500kHz, 3MHz	-2.5	0	2.5	dB

Note) The value may fluctuate by the influence of printed board, socket and etc.

■ Electrical Characteristics (Cont.) (Ta=25°C±2°C)

Parameter	Symbol	Condition	min.	typ.	max.	Unit
<b>AGC</b>						
AGC Max. Gain	G <sub>AGC</sub>	V <sub>CC</sub> =5V, f=500kHz, Sine Wave	10.0	14.5	19.0	dB
AGC Operation Gain	G <sub>OP-AGC</sub>	f=500kHz, V <sub>IN</sub> =500mV <sub>P-P</sub>	4	6	9	dB
AGC Compressibility	G <sub>cm-AGC</sub>	f=500kHz, V <sub>IN</sub> =100mV <sub>P-P</sub>	3	6	9	dB
AGC Frequency Characteristics	G <sub>f-AGC</sub>	f=3MHz, V <sub>IN</sub> =500mV <sub>P-P</sub>	-2	0	2	dB
<b>RFDET</b>						
RFDET Detection Operation	V <sub>NRF</sub>	f=500kHz	0.065	0.1	0.135	V <sub>P-P</sub>
RFDET H Level	V <sub>NRF-H</sub>	f=500kHz	4.2	—	—	V
RFDET L Level	V <sub>NRF-L</sub>	f=500kHz	—	—	0.8	V
<b>BDO</b>						
BDO Detection Current	I <sub>BDO</sub>	V <sub>CC</sub> =5V	1.0	1.4	1.8	μA
BDO H Level	V <sub>BDO-H</sub>	V <sub>CC</sub> =5V, f=2kHz Rectangle Wave	4.2	—	—	V
BDO L Level	V <sub>BDO-L</sub>	V <sub>CC</sub> =5V, f=2kHz Rectangle Wave	—	—	0.8	V
<b>OFTR</b>						
OFTR Detection Current	I <sub>OFTR</sub>	V <sub>CC</sub> =5V	1.0	1.4	1.8	μA
OFTR H Level	V <sub>OFTR-H</sub>	V <sub>CC</sub> =5V, f=2kHz Rectangle Wave	4.2	—	—	V
OFTR L Level	V <sub>OFTR-L</sub>	V <sub>CC</sub> =5V, f=2kHz Rectangle Wave	—	—	0.8	V
<b>LD – APC</b>						
LD ON H Input Level	V <sub>LDON-H</sub>	V <sub>CC</sub> =5V	3.5	—	—	V
LD OFF H Input Level	V <sub>LDOFF-H</sub>	V <sub>CC</sub> =5V	3.5	—	—	V
LD ON Operation Voltage (1)	V <sub>LD(1)</sub>	V <sub>CC</sub> =5V, V <sub>1</sub> : DC Sweep	0.135	0.170	0.205	V
<b>V. Detection</b>						
V. Det. Level (1)	V <sub>Det.(1)</sub>	V <sub>CC</sub> =5V, V <sub>23</sub> : DC Sweep	52	75	98	mV
V. Det. Level (2)	V <sub>Det.(2)</sub>	V <sub>CC</sub> =5V, V <sub>23</sub> : DC Sweep	-98	-75	-52	mV
V. Det. H Level	V <sub>Det.-H</sub>	V <sub>CC</sub> =5V, V <sub>23</sub> : DC Sweep	4.2	—	—	V
V. Det. L Level	V <sub>Det.-L</sub>	V <sub>CC</sub> =5V, V <sub>23</sub> : DC Sweep	—	—	0.8	V
<b>3TENV</b>						
CENV Detection Current	I <sub>CENV</sub>	V <sub>CC</sub> =5V	8.5	11	13.5	μA
CEA-ENV Transmission Characteristics	G <sub>CEA-ENV</sub>	V <sub>CC</sub> =5V	21	23	25	dB
CEA Input Impedance	R <sub>CEA</sub>	V <sub>CC</sub> =5V	6.5	8.25	9.5	kΩ
ENV Output Impedance	R <sub>ENV</sub>	V <sub>CC</sub> =5V	6.5	8.25	9.5	kΩ
ENV-Amp. Offset Voltage	V <sub>OP-ENV</sub>	V <sub>CC</sub> =5V	-70	0	70	mV
CEA-Amp. Operation Voltage	V <sub>OP-CEA</sub>	V <sub>CC</sub> =5V	50	125	200	mV

■ Operational Description (The values shown below are design values when supply voltage  $V_{CC}=5V$ .)

• RF Amplifier

As shown in Figure 1, RF signals are generated by three-beam method pick-up. Equivalent resistance to RFOUT (Pin7) is 57.6k $\Omega$ , when resistance between RF- and RFOUT is 12k $\Omega$ .

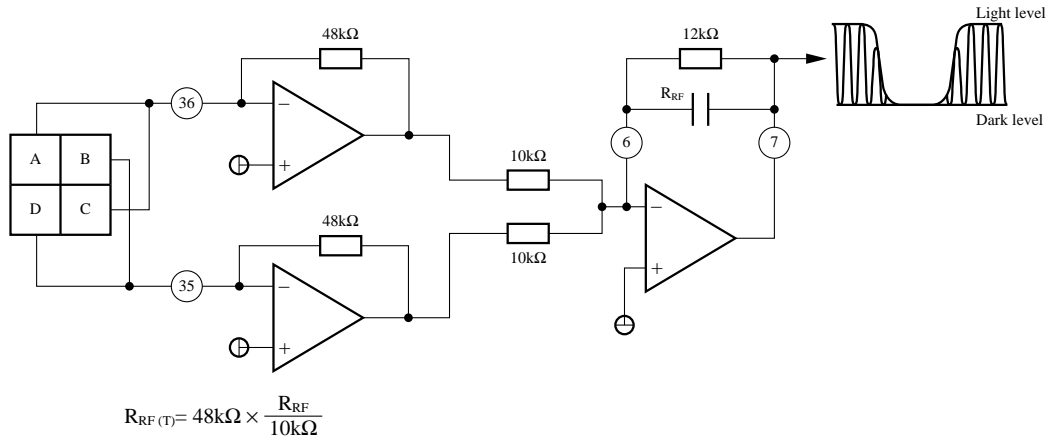

Figure 1 : RF Amplifier

• Focus Error Amplifier

As shown in Figure 2, the operation result of (A+C) – (B+D) is outputted to FEOUT (Pin27). Equivalent resistance to FEOUT is 96k $\Omega$ , when resistance between FE and FEOUT is 20k $\Omega$ .

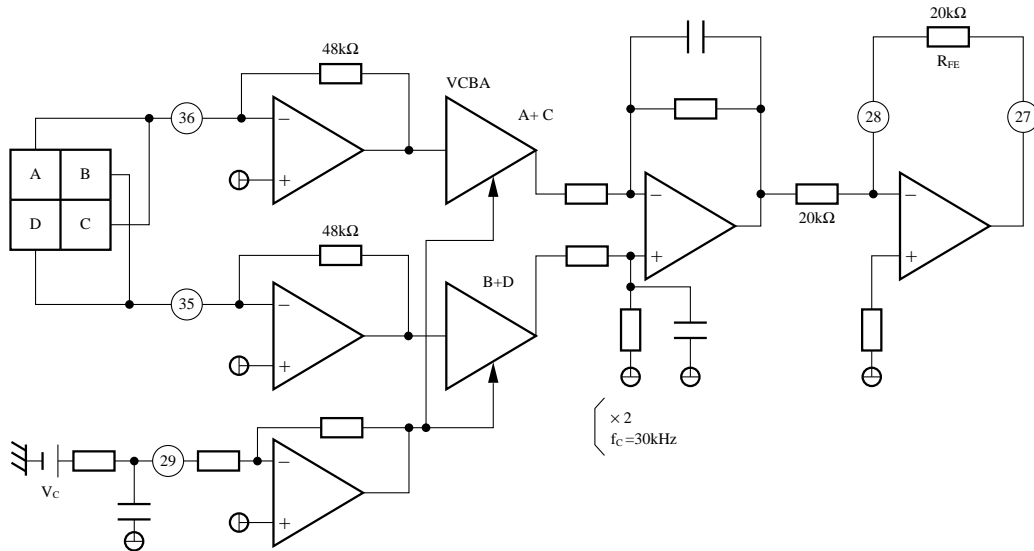

Figure 2 : Focus Error Amplifier

The VCBA is for focus balance adjustment. Connecting 47kΩ of external resistance to Pin299, signal ratio between A+C and B+D can be controlled as shown in Table 1.

Table 1

$V_c$	$\frac{A+C}{B+D}$	$\frac{B+D}{A+C}$
1.5V	0.14	7.0
2.5V	1.0	1.0
3.5V	7.0	0.14

• Tracking Error Amplifier

As shown in Figure 3, the tracking error amplifier receives the output currents E and F of three-beam method pin photo diode for sub-beam detection, and outputs the operation result of E-F to TEOOUT (Pin25).

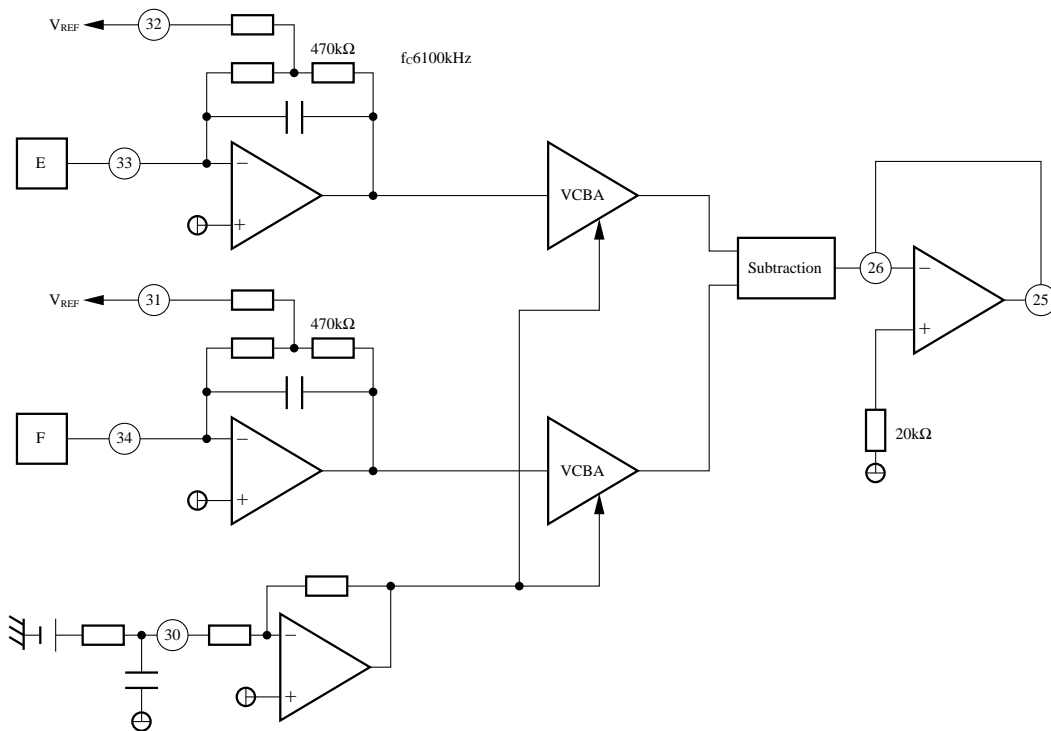

Figure 3 : Tracking Error Amplifier

Pin31, and 32 are used to make the resistance converting the current to voltage variable. When these pins are directly connected to  $V_{REF}$  and  $20k\Omega$  of resistance is connected between TE and TE-, and between TE and TEOUT respectively, equivalent resistance to TEOUT is  $629k\Omega$ .

Table 2

$V_c$	E/F	F/E
1.5V	0.14	7.0
2.5V	1.0	1.0
3.5V	7.0	0.14

The VCBA is for tracking balance adjustment in the same way of for focus. Table 2 shows the tracking balance ratio under the same conditions as shown in Table 1.

#### •AGC

In order to absorb the attenuation of RF signal by disk, pick-up dispersion, finger print and other factors, AGC circuit for RF is incorporated.

The input impedance of Pin8 is approx.  $27.9k\Omega$ . By Pin10 (ARF), the gain-controlled RF-signal is outputted. Input allowable level is approx.  $1V_{P-P} \sim 500mV_{P-P} \sim 250mV_{P-P}$ , and output is  $1V_{P-P}$ . Pin9 is a connecting pin with capacity for constructing the AGC loop filter. It is recommended that the external capacitor of  $1\mu F$  around should be connected to it for  $V_{CC}$ .

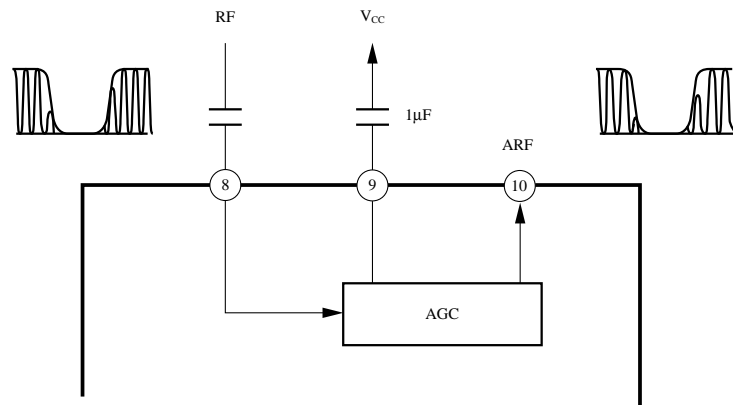

Figure 4 : AGC

#### •RFDET

The RFDET detects amplitude of RF signal inputted to Pin8. Threshold value is approx.  $100mV$  ( $f=500kHz$ ), and RF Present=L, RF Absent=H are outputted.



### •BDO Detection

BDO is detected by the low speed detection circuit and high speed detection circuit. The high speed detection circuit is incorporated. On the other hand, the capacitor of the low speed detection circuit must be connected to Pin13. The capacity value is 2200pF and it is recommended that it should be connected for  $V_{CC}$ . When the capacity value of Pin13 is increased, BDO is detected with large RF missing rate. When it is decreased, BDO can be detected with small RF missing rate.

BDO present=H

BDO absent=L

### •OFTR Detection

OFTR detection reversely corresponds with BDO detection. However, its detection method is the same as for BDO. Capacitor for the low speed detection must be connected to Pin15. It is recommended that it should be connected to  $V_{CC}$  at 2200pF in the same way as for Pin13. The relation between the capacity value and OFTR detection timing is as the same for BDO.

OFTR=H

Off from OFTR=L

### •APC

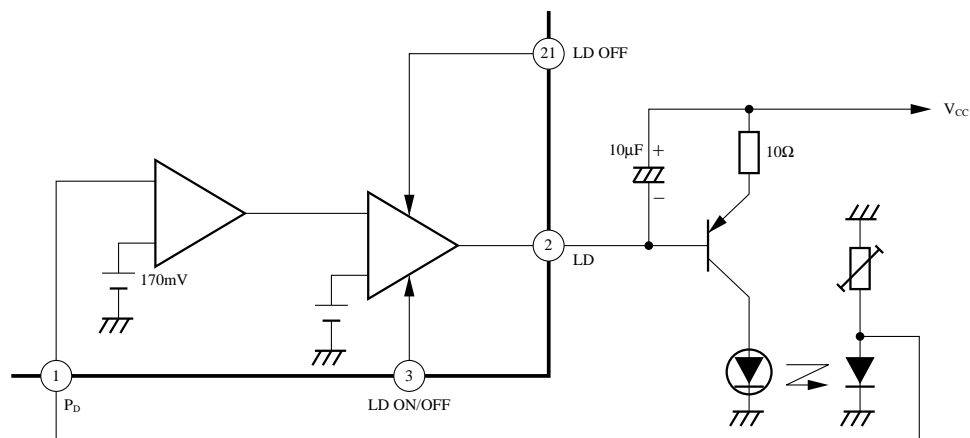

Figure 5 : APC

The reference voltage of LD is approx. 170mV fixed.

### •Reference Supply

Servo reference supply is incorporated. Pin20 outputs  $V_{CC}/2$ , and has approx. 3mA of current capacity for sink/source. It is recommended that it should be given 1µF to 10µF of capacity in addition.

### •Vibration Detection

The AN8807SB has a wind comparator of approx.  $\pm 75$  mV. Abnormal vibration components of tracking error are detected and the data for whether vibration is present or not is outputted to Pin22.

### •Envelope Detection

The envelope detection circuit extracts fluctuation of RF signal required for adjustment of focus balance.

Pin11 and 12 are connecting pins with capacity for constructing the filter. It is recommended that for Pin11, a capacitor of 100pF around, and for Pin12, an external capacitor of 0.027 $\mu$ F around should be connected against  $V_{CC}$ .

Pin19 is for output and must have external capacity for constructing the filter, and it is recommended that an external capacitor of 0.027 $\mu$ F around should be connected to it for  $V_{REF}$ .

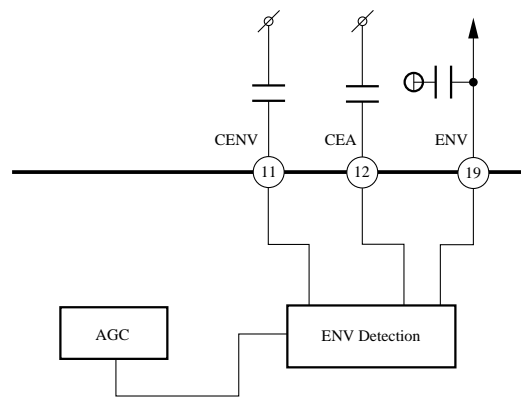

Figure 6 : Envelope Detection

### •CROSS Detection

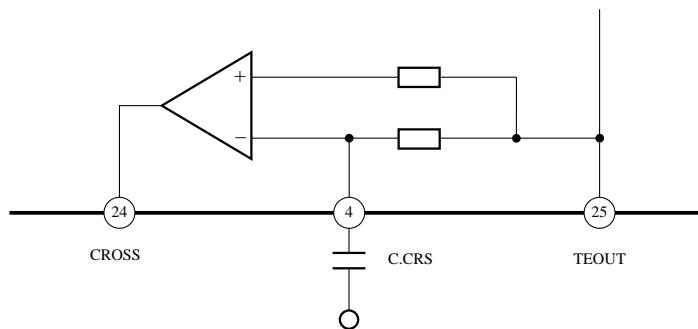

Figure 7 : CROSS Detection

Track cross signals are detected from tracking error output. Pin4 is a connecting pin for constructing the filter, and it is recommended that a capacitor of 2.2 $\mu$ F around should be connected to it for  $V_{REF}$ .