

AN8814SB

4-channel driver IC for optical disk drive

Overview

The AN8814SB is a BTL system 4-channel driver and is encapsulated in the SMD package which excels in heat radiation characteristic.

Features

- Wide output dynamic range regardless of reference voltage of the system
- Driver I/O gain setting is possible with an additional external resistor
- 3.3 V supply voltage is available due to an external PNP-tr.
- Additional OP-amp. built-in

Applications

- MD, CD/CD-ROM drive
- DVD/DVD-ROM drive

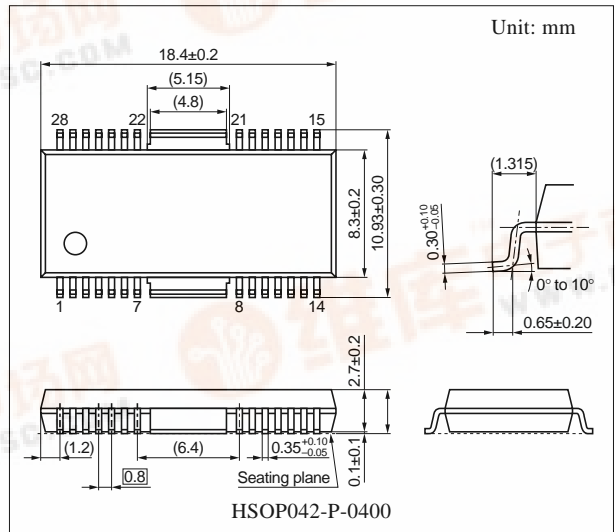

Block Diagram

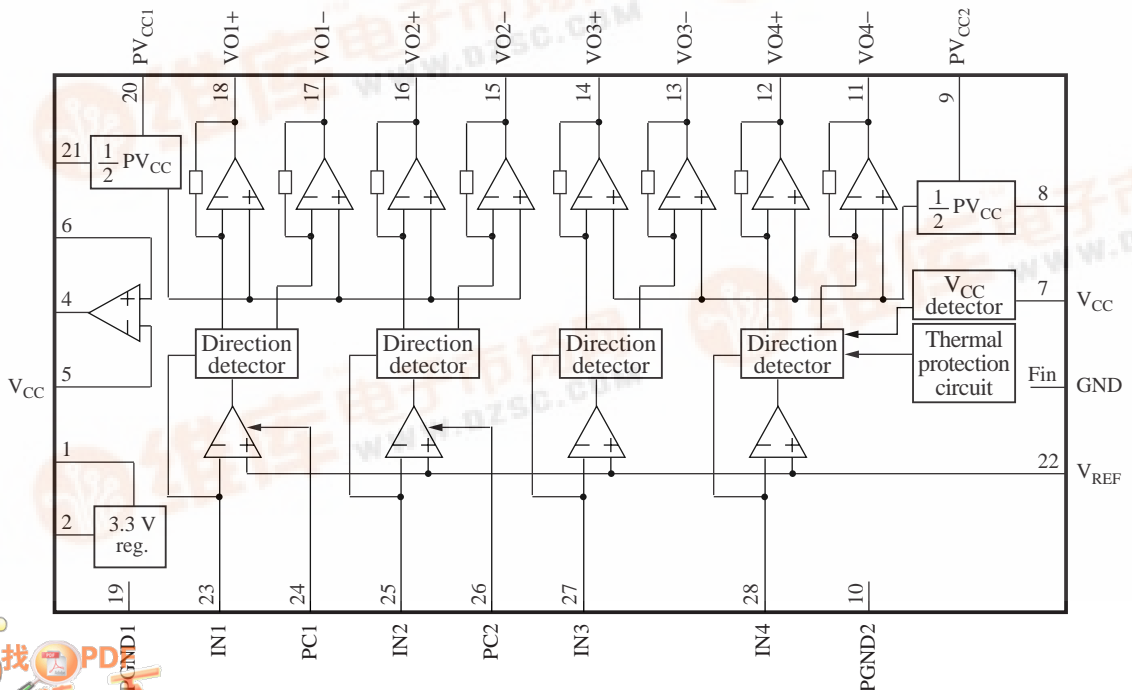

■ Pin Descriptions

Pin No.	Description	Pin No.	Description
1	Base control pin for an external transistor of 3.3 V regulator	15	Motor driver-2 reverse rotation output pin
		16	Motor driver-2 forward rotation output pin
2	3.3 V regulator output monitor pin	17	Motor driver-1 reverse rotation output pin
3	N.C. pin	18	Motor driver-1 forward rotation output pin
4	Op-amp. output pin	19	Driver GND pin 1
5	Op-amp. inverted input pin	20	Driver power supply pin 1
6	Op-amp. non-inverted input pin	21	1/2 PV _{CC} output pin 1
7	Power supply pin	22	V _{REF} input pin
8	1/2 PV _{CC} output pin 2	23	Motor driver-1 input pin
9	Driver power supply pin 2	24	PC (power cut) input pin 1
10	Driver GND pin 2	25	Motor driver-2 input pin
11	Motor driver-4 reverse rotation output pin	26	PC (power cut) input pin 2
12	Motor driver-4 forward rotation output pin	27	Motor driver-3 input pin
13	Motor driver-3 reverse rotation output pin	28	Motor driver-4 input pin
14	Motor driver-3 forward rotation output pin	Fin	GND pin

■ Absolute Maximum Ratings

Parameter	Symbol	Rating	Unit
Supply voltage	SV _{CC}	17	V
Supply current	I _{CC}	—	mA
Power dissipation *2	P _D	542	mW
Operating ambient temperature *1	T _{opr}	-30 to +85	°C
Storage temperature *1	T _{stg}	-55 to +150	°C

Note) *1: Except for the operating ambient temperature and storage temperature, all ratings are for T_a = 25°C.

*2: T_a = 85°C.

Referring to "■ Application Circuit Example", following the allowable power dissipation characteristic curve of "■ Application Notes".

■ Recommended Operating Range

Parameter	Symbol	Range	Unit
Supply voltage	SV _{CC} , PV _{CC1} , PV _{CC2}	4.0 to 14	V

■ Electrical Characteristics at $T_a = 25^\circ\text{C}$

Parameter	Symbol	Conditions	Min	Typ	Max	Unit
Current consumption with no load	I_{TOT}	$V_{\text{CC}} = 5\text{ V}$	5	10	15	mA
Motor driver 1 to motor driver 4						
Input offset voltage	V_{IOF}	$V_{\text{CC}} = 5\text{ V}$, $V_{\text{PC1}} = V_{\text{PC2}} = 0\text{ V}$, R_{L1} to $R_{\text{L4}} = 8\text{ k}\Omega$, R_1 to $R_4 = 10\text{ k}\Omega$	-10	0	10	mV
Output offset voltage	V_{OOF}	$V_{\text{CC}} = 5\text{ V}$, $V_{\text{PC1}} = V_{\text{PC2}} = 0\text{ V}$, R_{L1} to $R_{\text{L4}} = 8\text{ k}\Omega$, R_1 to $R_4 = 10\text{ k}\Omega$	-50	0	50	mV
Gain	G	$V_{\text{CC}} = 5\text{ V}$, $V_{\text{PC1}} = V_{\text{PC2}} = 0\text{ V}$, R_{L1} to $R_{\text{L4}} = 8\text{ k}\Omega$, R_1 to $R_4 = 10\text{ k}\Omega$	18.0	20.0	22.0	dB
Maximum output amplitude (+)	$V_{\text{L+}}$	$V_{\text{CC}} = 5\text{ V}$, $V_{\text{PC1}} = V_{\text{PC2}} = 0\text{ V}$, R_{L1} to $R_{\text{L4}} = 8\text{ k}\Omega$, R_1 to $R_4 = 10\text{ k}\Omega$	2.4	2.7	—	V
Maximum output amplitude (-)	$V_{\text{L-}}$	$V_{\text{CC}} = 5\text{ V}$, $V_{\text{PC1}} = V_{\text{PC2}} = 0\text{ V}$, R_{L1} to $R_{\text{L4}} = 8\text{ k}\Omega$, R_1 to $R_4 = 10\text{ k}\Omega$	—	-2.7	-2.4	V
Motor driver 1						
High-level threshold voltage	V_{PCH1}	$V_{\text{CC}} = 5\text{ V}$, $R_{\text{L1}} = 8\text{ }\Omega$, $R_1 = 10\text{ k}\Omega$	2.0	—	—	V
Low-level threshold voltage	V_{PCL1}	$V_{\text{CC}} = 5\text{ V}$, $R_{\text{L1}} = 8\text{ }\Omega$, $R_1 = 10\text{ k}\Omega$	—	—	0.5	V
Motor driver 2						
High-level threshold voltage	V_{PCH2}	$V_{\text{CC}} = 5\text{ V}$, $R_{\text{L2}} = 8\text{ }\Omega$, $R_2 = 10\text{ k}\Omega$	2.0	—	—	V
Low-level threshold voltage	V_{PCL2}	$V_{\text{CC}} = 5\text{ V}$, $R_{\text{L2}} = 8\text{ }\Omega$, $R_2 = 10\text{ k}\Omega$	—	—	0.5	V
Reset circuit						
Reset operation release supply voltage	V_{RST}	$I_{\text{IN}} = 10\text{ }\mu\text{A}$, R_1 to $R_4 = 10\text{ k}\Omega$	2.1	2.3	2.5	V
3.3 V regulator						
Output voltage	V_{REG}	$V_{\text{CC}} = 5\text{ V}$	3.1	3.3	3.5	V
Output load fluctuation	ΔV_{R}	$V_{\text{CC}} = 5\text{ V}$	-50	0	50	mV
Supply voltage fluctuation	ΔV_{V}	$V_{\text{CC}} = 5\text{ V}/12\text{ V}$	-5	0	5	mV
Op-amp.						
Input offset voltage	V_{OF}	$V_{\text{CC}} = 5\text{ V}$	-10	0	10	mV
Input bias current	I_{BOP}	$V_{\text{CC}} = 5\text{ V}$	—	150	500	nA
High-level output voltage	V_{OH}	$V_{\text{CC}} = 5\text{ V}$	4.0	—	—	V
Low-level output voltage	V_{OL}	$V_{\text{CC}} = 5\text{ V}$	—	—	1.5	V
Output driving current sink	I_{SIN}	$V_{\text{CC}} = 5\text{ V}$	2.0	—	—	mA
Output driving current source	I_{SOU}	$V_{\text{CC}} = 5\text{ V}$	2.0	—	—	mA

■ Electrical Characteristics at $T_a = 25^\circ\text{C}$ (continued)

• Design reference data

Note) The characteristics listed below are theoretical values based on the IC design and are not guaranteed.

Parameter	Symbol	Conditions	Min	Typ	Max	Unit
Thermal protection circuit						
Operating temperature equilibrium value	T_{THD}		—	180	—	$^\circ\text{C}$
Operating temperature hysteresis width	ΔT_{THD}		—	45	—	$^\circ\text{C}$

■ Usage Notes

1. Avoid the short-circuits between output and V_{CC} , and between output pin and GND. Otherwise, the IC is likely to break down or emit smoke.
2. An appropriate prior study should be done for use of dip soldering.

■ Application Notes

- $P_D - T_a$ curves of HSOP042-P-0400

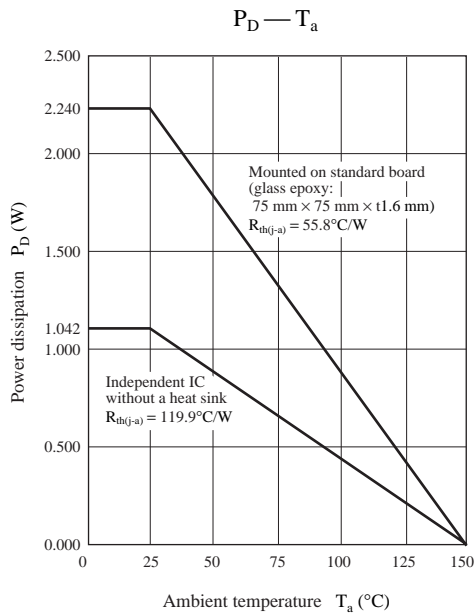

■ Application Circuit Example

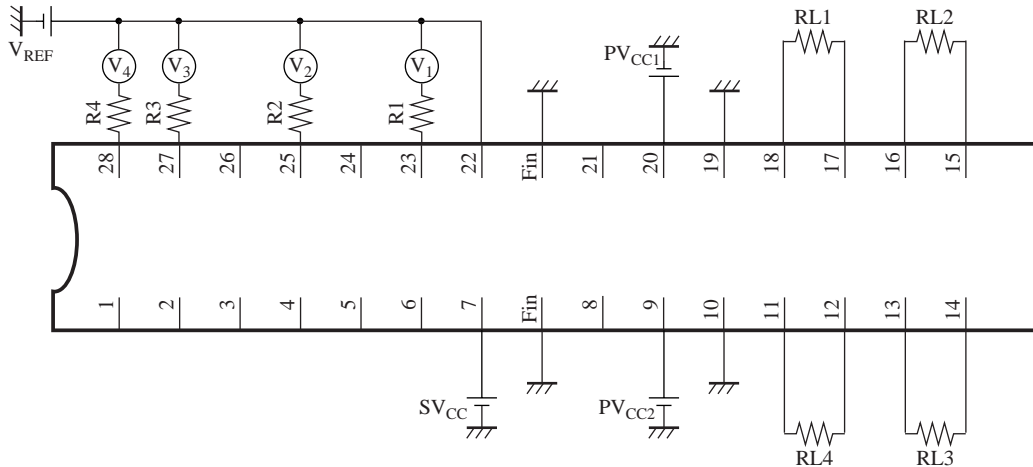

When the AN8814SB is use, take into account the following cautions and follow the power dissipation characteristic curve.

1. Load current I_{P1} flowing into load RL1, RL2 is supplied through pin 20.

$$I_{P1} = \frac{|V_{18} - V_{17}|}{R_{L1}} + \frac{|V_{16} - V_{15}|}{R_{L2}}$$

2. Load current I_{P2} flowing into load RL3, RL4 is supplied through pin 9.

$$I_{P2} = \frac{|V_{14} - V_{13}|}{R_{L3}} + \frac{|V_{12} - V_{11}|}{R_{L4}}$$

3. Dissipation increase (ΔP_D) inside the IC (power output stage) caused by loads RL1, RL2, RL3 and RL4 is as follows:

$$\begin{aligned} \Delta P_D &= (PV_{CC1} - |V_{18} - V_{17}|) \times \frac{|V_{18} - V_{17}|}{R_{L1}} + (PV_{CC1} - |V_{16} - V_{15}|) \times \frac{|V_{16} - V_{15}|}{R_{L2}} \\ &= (PV_{CC2} - |V_{14} - V_{13}|) \times \frac{|V_{14} - V_{13}|}{R_{L3}} + (PV_{CC2} - |V_{12} - V_{11}|) \times \frac{|V_{12} - V_{11}|}{R_{L4}} \end{aligned}$$

4. Dissipation increase (ΔP_S) inside the IC (signal block supplied from pin 7) caused by loads RL1, RL2, RL3 and RL4 comes roughly as follows:

$$\begin{aligned} \Delta P_S &= 3 \times \left\{ \frac{V_1}{R_1} \times (2 \times SV_{CC} + |V_{18} - V_{17}|) + \frac{V_2}{R_2} \times (2 \times SV_{CC} + |V_{16} - V_{15}|) \right. \\ &\quad \left. + \frac{V_3}{R_3} \times (2 \times SV_{CC} + |V_{14} - V_{13}|) + \frac{V_4}{R_4} \times (2 \times SV_{CC} + |V_{12} - V_{11}|) \right\} \end{aligned}$$

5. Dissipation increase in a driver operating mode is $\Delta P_D + \Delta P_S$.

6. Allowable power dissipation without load (P_{D1}) can be found as follows:

$$P_{D1} = SV_{CC} \times I_{SVCC} + PV_{CC1} \times I_{PVCC1} + PV_{CC2} \times I_{PVCC2}$$

7. Allowable power dissipation in a load operating mode (P_D) comes roughly as follows:

$$P_D = P_{D1} + \Delta P_D + \Delta P_S$$