

AN8946SB

FM demodulation IC for BS/CS broadcasting

Overview

The AN8946SB is a 5 V single power supply and low power consumption FM demodulation IC for BS/CS broadcasting. It features PLL · FM demodulation, 2nd IF AGC amp., AGC detection and AFC (applicable to both mean value and keyed types).

Features

- 5 V single power source
- Low power dissipation (typ. 170 mW)
- S/N 65 dB or more
- Inter-modulation interference ratio: 50 dB or more
- AGC amp built in (Reduction range: 55 dB)
- Adjustment-free VCO coil

Applications

- BS/CS tuner, television

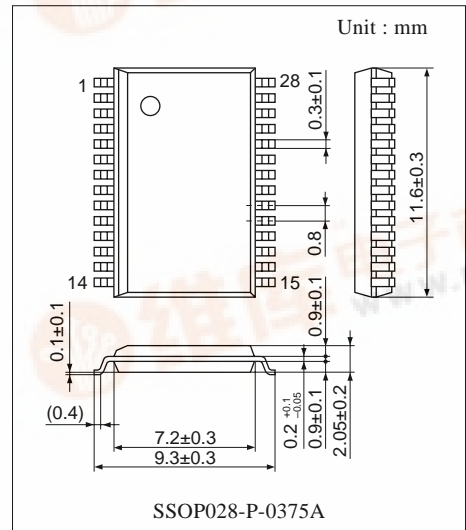

Block Diagram

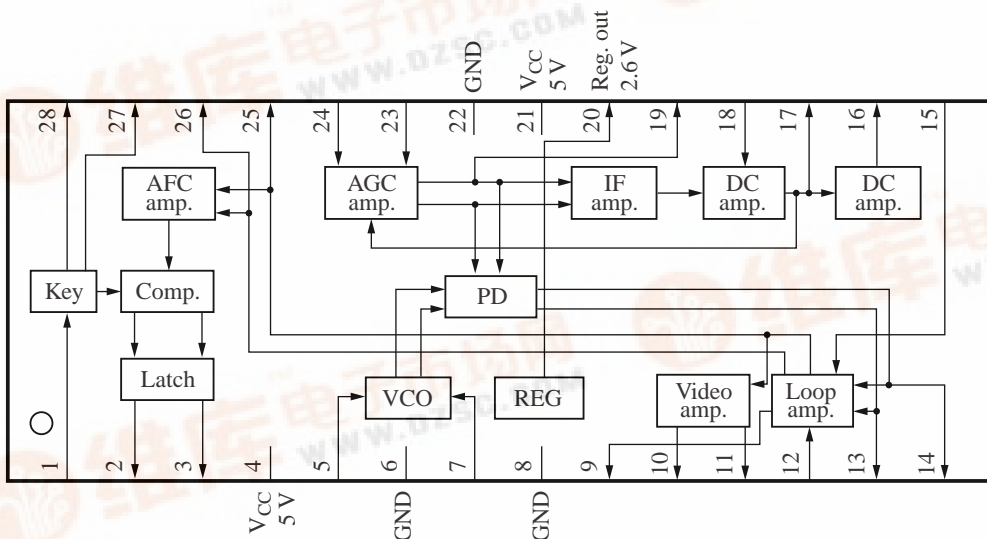

■ Pin Descriptions

Pin No.	Description	Pin No.	Description
1	Key pulse input	15	AFC adjustment
2	AFC output L	16	AGC output 2
3	AFC output H	17	AGC output 1
4	V _{CC2} (VCO, AFC system)	18	AGC adjustment
5	VCO1	19	IF amp. output
6	GND3 (VCO system)	20	Regulator output
7	VCO2	21	V _{CC1} (Main)
8	GND2 (Main)	22	GND1 (AGC amp., regulator system)
9	Loop amp. output	23	IF amp. input 2
10	Video amp. input	24	IF amp. input 1
11	Video amp. output	25	AFC output R
12	Free-run frequency adjustment	26	AFC LPF2
13	Loop amp. input 1	27	AFC LPF1
14	Loop amp. input 2	28	Key pulse LPF

■ Absolute Maximum Ratings

Parameter	Symbol	Rating	Unit
Supply voltage	V _{CC}	5.6	V
Supply current	I _{CC}	50	mA
Power dissipation	P _D	280	mW
Operating ambient temperature *	T _{opr}	-20 to +75	°C
Storage temperature *	T _{stg}	-55 to +150	°C

Note) 1. Be careful for static electricity damage of pin 1 to pin 5, pin 7, pin 21, pin 26 and pin 28.

2. *: Except for the operating ambient temperature and storage temperature, all ratings are for T_a = 25°C.

■ Recommended Operating Range

Parameter	Symbol	Range	Unit
Supply voltage	V _{CC}	4.5 to 5.5	V

■ Electrical Characteristics at $T_a = 25^\circ\text{C}$

Parameter	Symbol	Conditions	Min	Typ	Max	Unit
Total circuit current	I_{TOT}	$V_{\text{CC}} = 5\text{ V}$	28	34	40	mA
IF amp. maximum gain	GIF_{max}	$\text{PIF}_{\text{IN}} = -60\text{ dBm}$, $f = 402.78\text{ MHz}$ $V_{17} = 5\text{ V}$	22	25	28	dB
IF amp. minimum gain	GIF_{min}	$\text{PIF}_{\text{IN}} = 0\text{ dBm}$, $f = 402.78\text{ MHz}$ $V_{17} = 0\text{ V}$	—	-29	-25	dB
Loop amp. gain	G_{LA}	PLA in = -30 dBm, $f = 1\text{ MHz}$	22	24	26	dB
Video amp. gain	G_{VA}	PVA in = -10 dBm, $f = 1\text{ MHz}$	6.5	7.0	7.5	dB
VCO control sensitivity	β	$f = 402.78\text{ MHz}$	37	39	41	MHz/V
Signal to noise ratio ($C/N = \infty$)	S/N_{max}	$\text{PIF}_{\text{IN}} = -30\text{ dBm}$, 100%W, weighting LPF 4.2 MHz, HPF 10 kHz	62	67	—	dB
Inter-modulation interference ratio (2nd)	IM_2	$\text{PIF}_{\text{IN}} = -30\text{ dBm}$, $f_{\text{C}} = 3.58\text{ MHz}$ $f_{\text{S}} = 5.7272\text{ MHz}$	40	60	—	dB
Inter-modulation interference ratio (3rd)	IM_3	$\text{PIF}_{\text{IN}} = -30\text{ dBm}$, $f_{\text{C}} = 3.58\text{ MHz}$ $f_{\text{S}} = 5.7272\text{ MHz}$	40	60	—	dB
AFC dead-band width	BW_{AFC}	Pin 2: Low, Pin 3: High	310	360	420	kHz
AFC output maximum voltage	V_{AFCH}	$V_{\text{CC}} - V_3$ value, $f = 402.78\text{ MHz}$	—	0	0.5	V
AFC output minimum voltage	V_{AFCL}	V_2 value, $f = 402.78\text{ MHz}$	—	0.1	0.5	V
AGC output maximum voltage 1	V_{AGC1H}	$V_{\text{CC}} - V_{17}$ value, $\text{PIF}_{\text{IN}} = -70\text{ dBm}$	—	0	0.2	V
AGC output minimum voltage 1	V_{AGC1L}	$\text{PIF}_{\text{IN}} = +10\text{ dBm}$	—	0.3	0.5	V
AGC output maximum voltage 2	V_{AGC2H}	$V_{\text{CC}} - V_{16}$ value, $\text{PIF}_{\text{IN}} = -70\text{ dBm}$	—	0	0.2	V
AGC output minimum voltage 2	V_{AGC2L}	$\text{PIF}_{\text{IN}} = +10\text{ dBm}$	—	0.3	0.5	V
AGC SW level	Pin_{SW}	$f = 402.78\text{ MHz}$, $\text{PIF}_{\text{M}} = -50\text{ dBm}$ Input level at $V_{16} = 2.5\text{ V}$	-39	-35	-31	dBm
Key pulse input maximum voltage	V_{KEYH}	DC measurement	0.35	—	—	V
Key pulse input minimum voltage	V_{KEYL}	DC measurement	—	—	0.1	V
Noise amplitude	V_{N}	$f = 402.78\text{ MHz}$ with no modulation and with de-emphasis Measure it at Video out pin.	—	4	10	mV[p-p]
Pin 12 voltage	V_{12}	Voltage to get $V_{17} = 0\text{ V}$, $V_2 \leq 1\text{ V}$, $V_3 \geq 4\text{ V}$ with no PIF_{IN} .	1.0	1.35	1.7	V
Pin 15 voltage	V_{15}	Voltage to be AFC center with no PIF_{IN} , $V_{17} = 0\text{ V}$, $f_{\text{VCO}} = 402.78\text{ MHz}$	1.03	1.15	1.27	V

• Design reference data

Note) The characteristics listed below are theoretical values based on the IC design and are not guaranteed.

Parameter	Symbol	Conditions	Min	Typ	Max	Unit
IF amp. frequency characteristic	f_{CIF}	3 dB down frequency	600	700	—	MHz
IF amp. NF	NF_{IF}	$f = 402.78\text{ MHz}$, $V_{17} = 5\text{ V}$	—	12	15	dB
Loop amp. frequency characteristic	f_{CLA}	3 dB down frequency	200	250	—	MHz
Loop amp. phase	PH_{LA}	$f = 1\text{ MHz}$ to 20 MHz	—	± 5	± 10	$^\circ$

■ Electrical Characteristics at $T_a = 25^\circ\text{C}$ (continued)

• Design reference data

Note) The characteristics listed below are theoretical values based on the IC design and are not guaranteed.

Parameter	Symbol	Conditions	Min	Typ	Max	Unit
Video amp. frequency characteristic	ΔG_{VAF}	PVA in = -10 dBm, $G_{VA} = 7$ dB f = 50 Hz to 10 MHz	—	± 0.1	± 0.3	dB
Video amp. phase	PH_{VA}	f = 50 Hz to 10 MHz, $G_{VA} = 7$ dB	—	± 10	± 20	°
PD detection sensitivity	$K\phi$	f = 402.78 MHz, $PIF_M = -50$ dBm	80	90	100	mv/rad
PD frequency characteristic	$\Delta K\phi_F$	f = 400 MHz to 500 MHz	—	± 10	± 20	mv/red
VCO C/N	C/N	f = 402.78 MHz, ± 50 kHz	45	48	—	dB
IF amp. input return loss	RL	f = 402.78 MHz	—	-15	-10	dB
IF input level	PIF_{IN}	Pin 24 input level	-55	-30	-5	dBm
AGC regulation	ΔPIF_M	f = 402.78 MHz $PIF_{IN} = -50$ dBm to -10 dBm	—	± 0.5	± 1.0	dB
AGC detection sensitivity	ΔV_{AGC2}	Pin 16 output sensitivity	4	5	—	V/dB
Lock range	LR	$PIF_{IN} = -50$ dBm to -10 dBm	± 18	± 20	—	MHz
Capture range	CR	$PIF_{IN} = -50$ dBm to -10 dBm	± 14	± 18	—	MHz
Demodulation frequency characteristic	ΔV_{OF}	f = 50 Hz to 10 MHz	—	± 0.2	± 0.5	dB
Demodulation group delay characteristic	GD	f = 50 Hz to 10 MHz	—	± 5	± 10	ns
Differential gain	DG	APL 10% to 90%	—	0.5	1.0	%
Differential phase	DP	APL 10% to 90%	—	0.5	1.0	°
AGC SW level temperature characteristic	ΔP_{SWT}	$T_a = 25^\circ\text{C}$ typical $T_a = -10^\circ\text{C}$ to $+80^\circ\text{C}$	—	± 1.0	± 2.0	dB
Free-run frequency temperature characteristic	Δf_{OSCT}	$T_a = 25^\circ\text{C}$ typical $T_a = -10^\circ\text{C}$ to $+80^\circ\text{C}$	—	± 0.5	± 1.0	MHz
AFC center frequency temperature characteristic	Δf_{AFCT}	$T_a = 25^\circ\text{C}$ typical $T_a = -10^\circ\text{C}$ to $+80^\circ\text{C}$	—	± 0.5	± 1.0	MHz
AFC dead-band width temperature characteristic	ΔBW_{AFCT}	$T_a = 25^\circ\text{C}$ typical $T_a = -10^\circ\text{C}$ to $+80^\circ\text{C}$	—	+80 -40	+100 -50	kHz
IF monitor level temperature characteristic	ΔPIF_M	$T_a = 25^\circ\text{C}$ typical $T_a = -10^\circ\text{C}$ to $+80^\circ\text{C}$	—	± 0.5	± 1.0	dB
Free-run frequency SW on drift	Δf_{OSCSW}	t = 10 minutes later, referring to 3 s after V_{CC} SW on	—	± 0.2	± 0.5	MHz
Video amp. base current	I_{10}	Pin 9 open, R10 - R11 = 100 k Ω	1.0	2.4	5.2	μA
Regulator output voltage	V_{20}	$V_{CC} = 5$ V	2.4	2.6	2.8	V
Regulator output voltage fluctuation	ΔV_{20}	$V_{CC} = 4.5$ V to 5.5 V	—	± 5	± 15	mV

■ Terminal Equivalent Circuits

Pin No.	Equivalent circuit	Description	Voltage (Open)
1		<p>Key pulse input</p> <ul style="list-style-type: none"> No input at receiving NTSC signal. Input a key pulse in a direct DC connection at receiving MUSE signal. 	30 mV
2		<p>AFC output L</p> <ul style="list-style-type: none"> Output impedance can be lowered by adding an external resistor. 	0 V to 5 V
3		<p>AFC output H</p> <ul style="list-style-type: none"> Output impedance can be lowered by adding an external resistor. 	0 V to 5 V
4		<p>V_{CC2}</p> <ul style="list-style-type: none"> Supply power for VCO, AFC 	Apply 5 V from outside
5		<p>VCO1</p> <ul style="list-style-type: none"> Connects a resonance circuit between pin 5 and pin 7. 	Floating
6		<p>GND3</p> <ul style="list-style-type: none"> GND for VCO, AFC 	Apply 0 V from outside
7	<p>Same as VCO1</p>	<p>VCO2</p> <ul style="list-style-type: none"> Connects a resonance circuit between pin 5 and pin 7. 	Floating

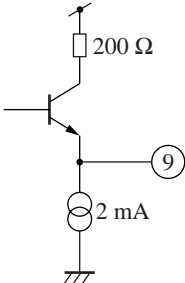
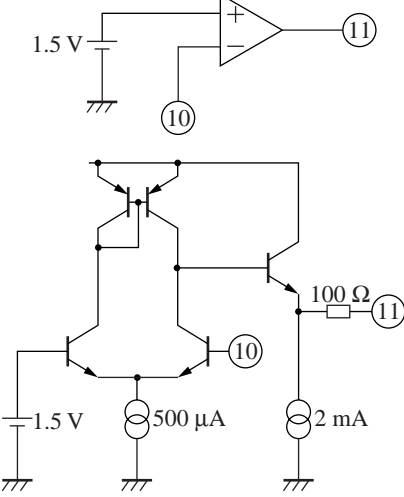
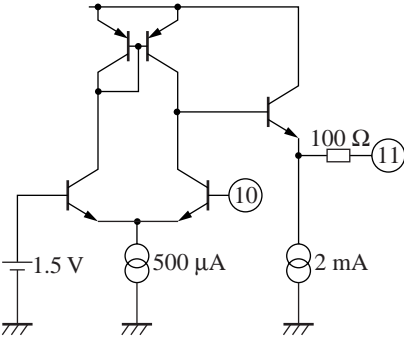
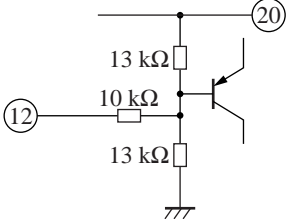

■ Terminal Equivalent Circuits (continued)

Pin No.	Equivalent circuit	Description	Voltage (Open)
8		<p>GND2</p> <ul style="list-style-type: none"> GND pin except VCO, AFC and IF amp. 	<p>Apply 0 V from outside</p>
9		<p>Loop amp. output</p> <ul style="list-style-type: none"> pin to drive a variable capacitance diode for VCO. 	<p>1.5 V</p>
10		<p>Pin 10 Video amp. input Pin 11 Video amp. output</p> <ul style="list-style-type: none"> Pin 10 is a reverse phase input pin to pin 11. When a resistor between pin 9 and pin 10 is R1 and a resistor between pin 10 and pin 11 is R2, the gain is R2/R1 and a reverse signal to pin 9 is outputted from pin 11 	<p>Floating</p>
11			<p>4.2 V</p>
12		<p>Free-run frequency adjustment</p> <ul style="list-style-type: none"> Changing pin 12 potential enables you to cancel an offset voltage of a loop amp. 	<p>1.3 V</p>

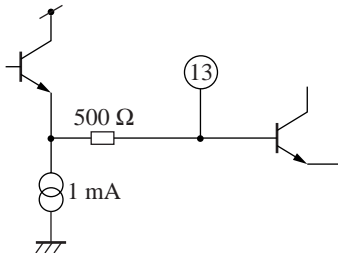
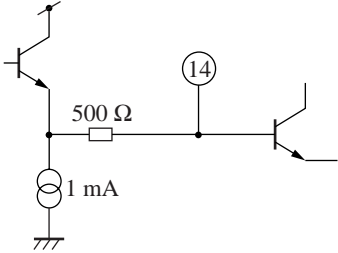
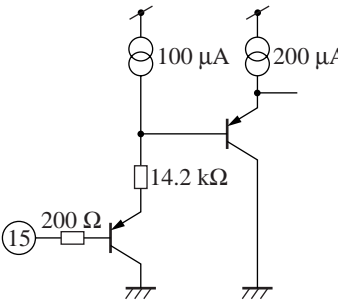
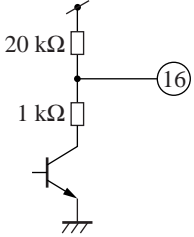
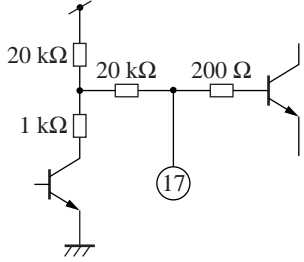
■ Terminal Equivalent Circuits (continued)

Pin No.	Equivalent circuit	Description	Voltage (Open)
13		<p>Loop amp. input 1</p> <ul style="list-style-type: none"> Connect a lag-lead filter between pin 13 and pin 14. 	1.5 V
14		<p>Loop amp. input 2</p> <ul style="list-style-type: none"> Connect a lag-lead filter between pin 13 and pin 14. 	1.5 V
15		<p>AFC adjustment</p> <ul style="list-style-type: none"> Adjust a center frequency of AFC by changing pin 15 potential. 	4.8 V
16		<p>AGC output 2</p> <ul style="list-style-type: none"> Output pin for external AGC (previous stage) 	5 V
17		<p>AGC output 1</p> <ul style="list-style-type: none"> Filter pin for inner AGC 	5 V

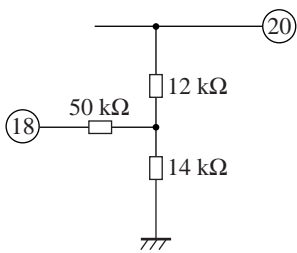
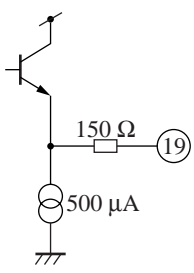
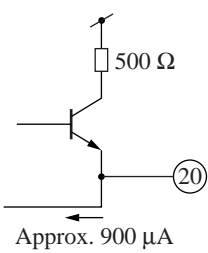
■ Terminal Equivalent Circuits (continued)

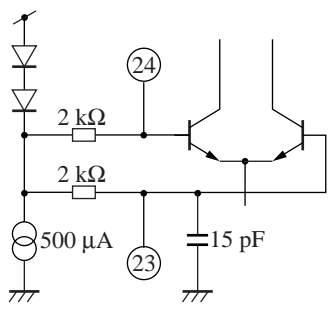
Pin No.	Equivalent circuit	Description	Voltage (Open)
18		AGC adjustment • Inner AGC adjustment pin • Use at adjusting an IF monitor level.	1.4 V
19		IF amp. output • Pin to check an IF amp. output level	3.3 V
20		Regulator output • 2.6 V reference voltage output pin • Driving capability is 1 mA.	2.6 V
21		V_{CC1} • Power supply pin except VCO, AFC	Apply 5 V from outside
22		GND1 • GND for IF amp. (AGC amp., regulator)	Apply 0 V from outside
23		IF amp. input 2 • IF amp. complementary input pin • Ground in AC with an external capacitor	3.2 V
24		IF amp. input • IF amp. input pin	3.2 V

■ Terminal Equivalent Circuits (continued)

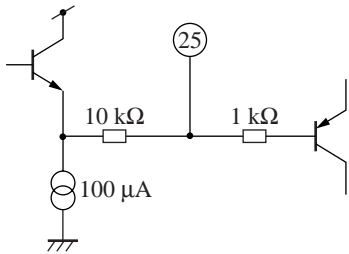
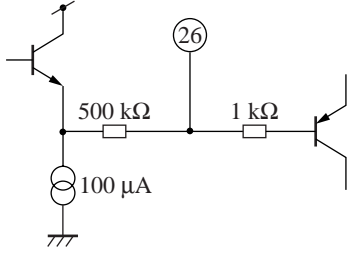
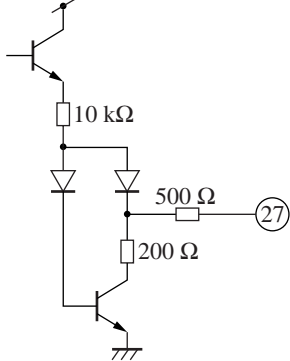
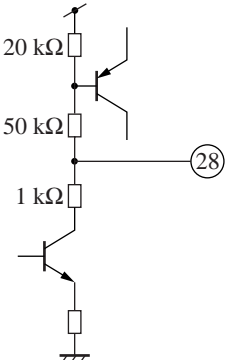
Pin No.	Equivalent circuit	Description	Voltage (Open)
25		<p>AFC output R</p> <ul style="list-style-type: none"> • Outputted is a center point potential of a loop amp. output dynamic range. • Also used as a reference power supply for video amp. 	1.5 V
26		<p>AFC LPF2</p> <ul style="list-style-type: none"> • Construct a filter with an output impedance approximately 500 kΩ at pin 26 and an external capacitor between pin 26 and pin 27. 	1.5 V
27		<p>AFC LPF1</p> <ul style="list-style-type: none"> • Low impedance (approximately 0.7 V) for low-level (0 V) of pin 1 • High impedance (floating) for high-level (0.5 V) of pin 1 	0.6 V
28		<p>Key pulse LPF</p> <ul style="list-style-type: none"> • Pin to smooth a key pulse • Identifying a key pulse by this pin. 	0 V

■ Application Circuit Example

