

2004.08.30

### DESCRIPTION

The AP1093 is a linear, low current power amplifier in ISM band utilizing InGaP /GaAs HBT process. It features a low current of 130mA, high gain of 30 dB, linear power of 19dBm and PAE of 18% for 802.11g under 3.3V. The AP1093 is housed in a 3 x 3 (mm), 16-pin, QFN leadless package. The AP1093 is suitable to be used in 802.11b/g WLAN and other 2.4GHz applications.

### Major Applications

- IEEE 802.11b/g WLAN Clients
- IEEE 802.11b/g WLAN Access Points
- 2.4 GHz ISM Band

### Functional Block Diagram

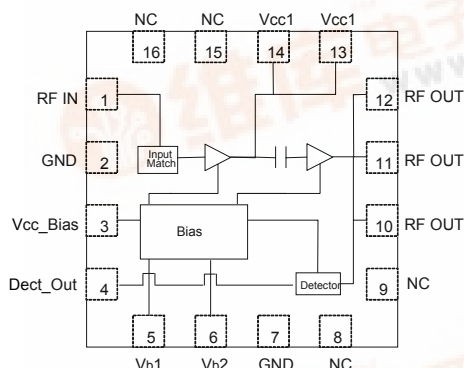

### KEY FEATURES

- **Low current :**  
130mA for 11g linear power(19dBm) at 3.3V  
175mA for 11g linear power(22dBm) at 5V
- **High Efficiency:**  
PAE>35% @802.11b linear power  
PAE>18% @802.11g linear power
- **High Gain: 30~31dB**
- **Detector**

### Pin Details

Pin Number	Name	Description
1	RF_IN	RF input
2	GND	DC and RF ground
3	Vcc_Bias	Supply voltage for bias circuit
4	Dect_Out	Power detector output
5	Vb1	1 <sup>st</sup> -stage control voltage
6	Vb2	2 <sup>nd</sup> -stage control voltage
7	GND	DC and RF ground
8	NC	No contact (Connect to ground for better thermal dissipation)
9	NC	
10	RF_OUT	RF output. Require external matching. The detail configuration can be found in Application Notes
11	RF_OUT	
12	RF_OUT	
13	VCC1	Supply voltage for first stage. Some bypass capacitors are needed for system application. The detail configuration can be found in Application Notes.
14	VCC1	
15	NC	No contact (Connect to ground for better thermal dissipation)
16	NC	
Package Base	Center Metal	The package ground provides circuit ground as well as heat dissipation path for the power amplifier.

© Vb2 can be connected with Vb1 pin into a single Vref through external resistor. (Please refer to the AP1093 Application note)

For more information, please contact us at:

© 2003 RF Integrated Corporation. All rights reserved.

Sales Dept.

Tel: +86-2-2698-1022

e-mail: sales@rfintc.com

RF integrated Corp. reserves the right to make any changes to the specifications without notice.

2004.08.30

### Electrical Characteristics

• Under  $V_c=3.3V$ ,  $V_{ref}=2.85V$ ,  $T_a=25^\circ C$

PARAMETER	CONDITION	SYMBOL	MIN.	TYP.	MAX.	UNIT
Freq.		f	2.4		2.5	GHz
Total current	Pout=19dBm, 64QAM/54Mbps Pout=24dBm, CCK/11Mbps	Icc		130 208		mA
Linear Output Power	EVM<3%, 64QAM/54Mbps			19		dBm
Bias control reference current	Icq=85mA	Iref		0.95		mA
Power Gain	Pout=19dBm, 64QAM/54Mbps	Gp		30		dB
Quiescent current		Icq		85		mA
EVM	Pout=19dBm, 64QAM/54Mbps	EVM		2.5		%
802.11b ACP-1 <sup>st</sup> Side Lobe	Pout=24dBm, CCK/11Mbps			-36		dBc
802.11b ACP-2 <sup>nd</sup> Side Lobe	Pout=24dBm, CCK/11Mbps			-51		dBc
Input VSWR				2:1		
Output VSWR				2.5:1		
PAE @ linear power	Pout=16dBm, 64QAM/54Mbps Pout=24dBm, CCK/11Mbps	PAE		18 35		%

2004.08.30

### Electrical Characteristics

- Under  $V_c=5V$ ,  $V_{ref}=2.95V$ ,  $T_a=25^\circ C$

PARAMETER	CONDITION	SYMBOL	MIN.	TYP.	MAX.	UNIT
Freq.		f	2.4		2.5	GHz
Total current	@ Pout=22dBm, 64QAM/54Mbps @Pout=27dBm, CCK/11Mbps	Icc		175 285		mA
Linear Output Power	EVM<3%, 64QAM/54Mbps			22		dBm
Bias control reference current	@Icq=105mA	Iref		1.1		mA
Power Gain	@ Pout=22dBm, 64QAM/54Mbps	Gp		29		dB
Quiescent current		Icq		105		mA
EVM	@ Pout=22dBm, 64QAM/54Mbps	EVM		3		%
802.11b ACP-1 <sup>st</sup> Side Lobe	@Pout=27dBm, CCK/11Mbps			-35		
802.11b ACP-2 <sup>nd</sup> Side Lobe	@Pout=27dBm, CCK/11Mbps			-51		
In put VSWR				2		
Out put VSWR				2.5		
PAE @ linear power	@ Pout=22dBm, 64QAM/54Mbps @Pout=27dBm, CCK/11Mbps	PAE		18 35		%

### Absolute Maximum Ratings

Parameter	Rating	Unit
DC Power Supply For Collector	+5	V
DC Supply Current For Collector	450	mA
RF Input Power	+5	dBm
Operating Ambient Temperature	-40 to +85	°C
Storage Temperature	-40 to +125	°C

### Important Note:

The information provided in this datasheet is deemed to be accurate and reliable only at present time. RF Integrated Corp. reserves the right to make any changes to the specifications in this datasheet without prior notice.

2004.08.30

**Fig. 1**  
**EVM & Icc vs. Pout (dBm)**

(Vc1=Vc2=Vcc\_bias=3.3V, Vref=2.85V, f=2.412GHz, 54Mbps OFDM Signal)

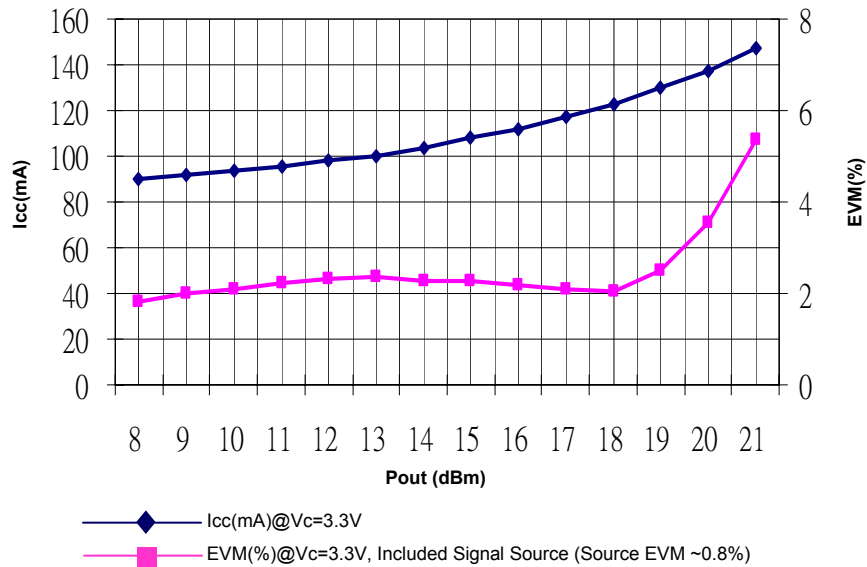

**Fig. 2**

**EVM vs. Frequency**  
(Pout=19dBm, With 54 Mb/s, OFDM Modulation)

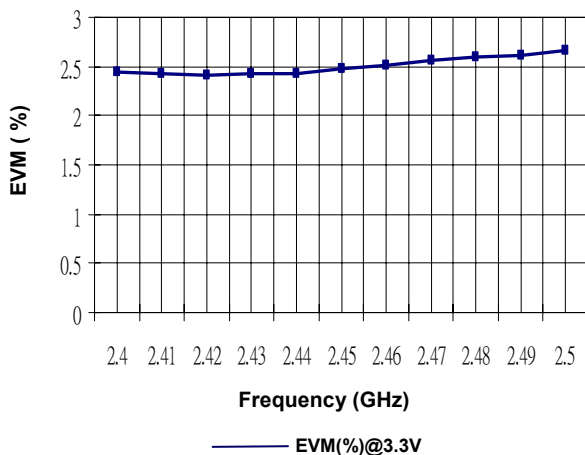

**Fig. 3**

**Gain, P<sub>OUT</sub>, PAE vs. P<sub>IN</sub>**

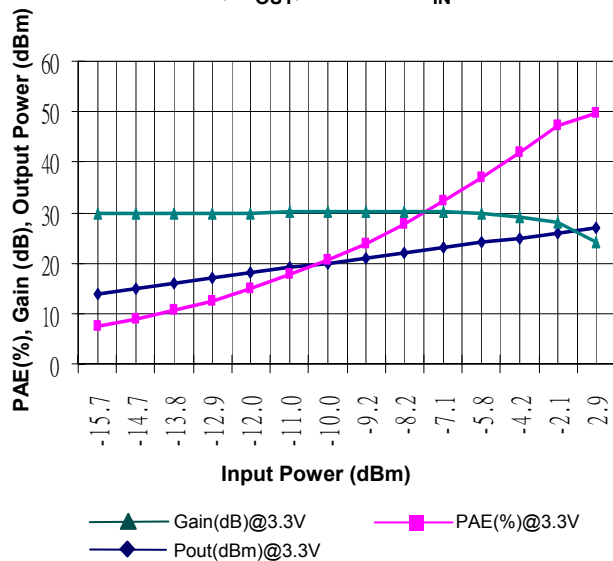

For more information, please contact us at:

Sales Dept.

Tel: +886-2-2698-1022

e-mail: sales@rfintc.com

© 2003 RF Integrated Corporation. All rights reserved.

RF integrated Corp. reserves the right to make any changes to the specifications without notice.

2004.08.30

Fig. 4

Detector Output vs. Output Power

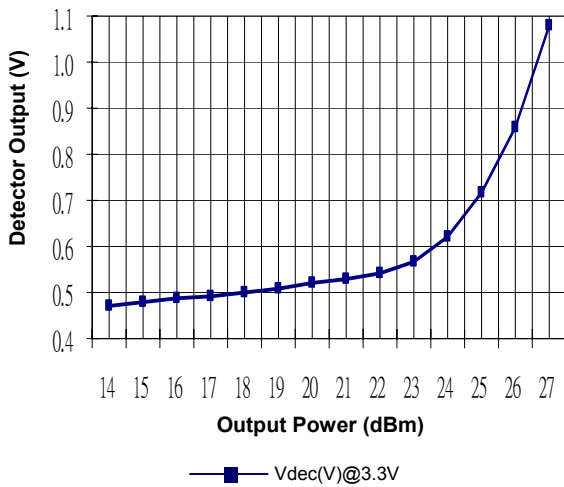

Fig. 5

Power Gain vs. Frequency

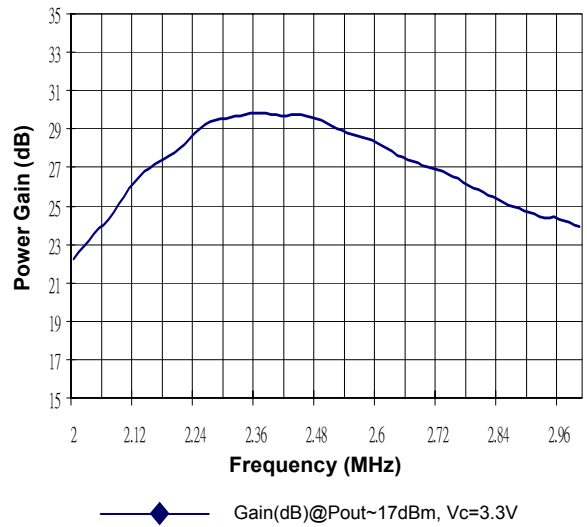

Fig. 6

Input Return Loss vs. Frequency

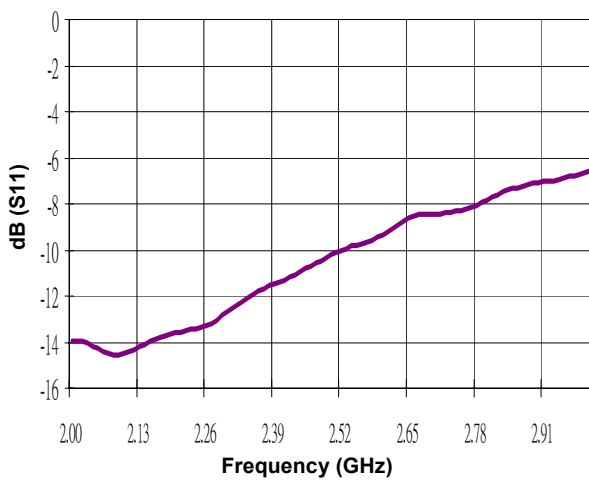
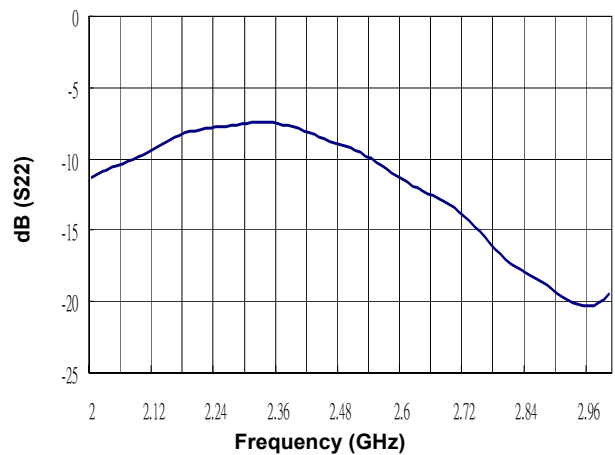

Fig. 7

Output Return Loss vs. Frequency



2004.08.30

Fig. 8

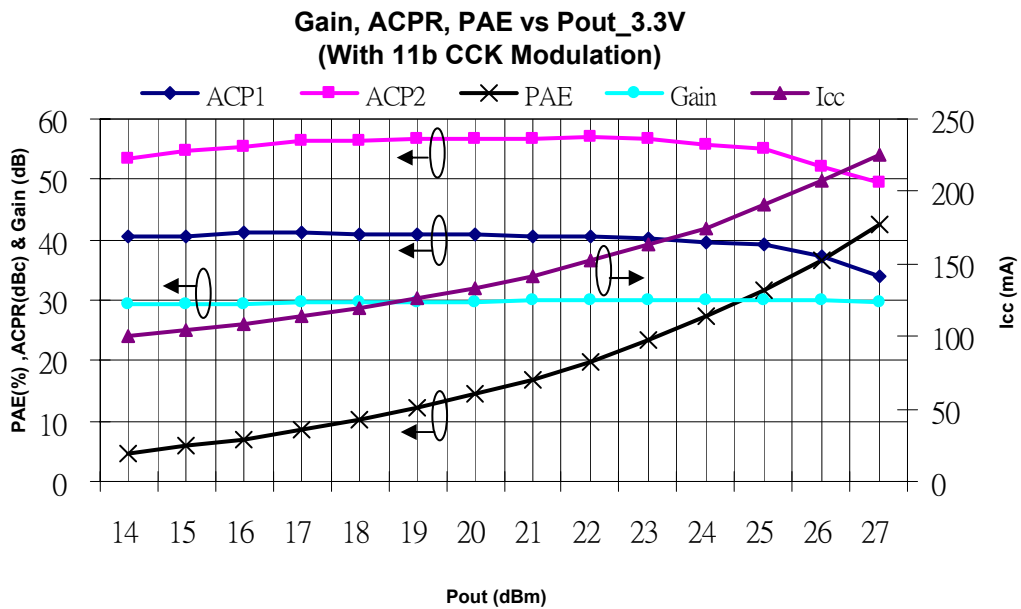
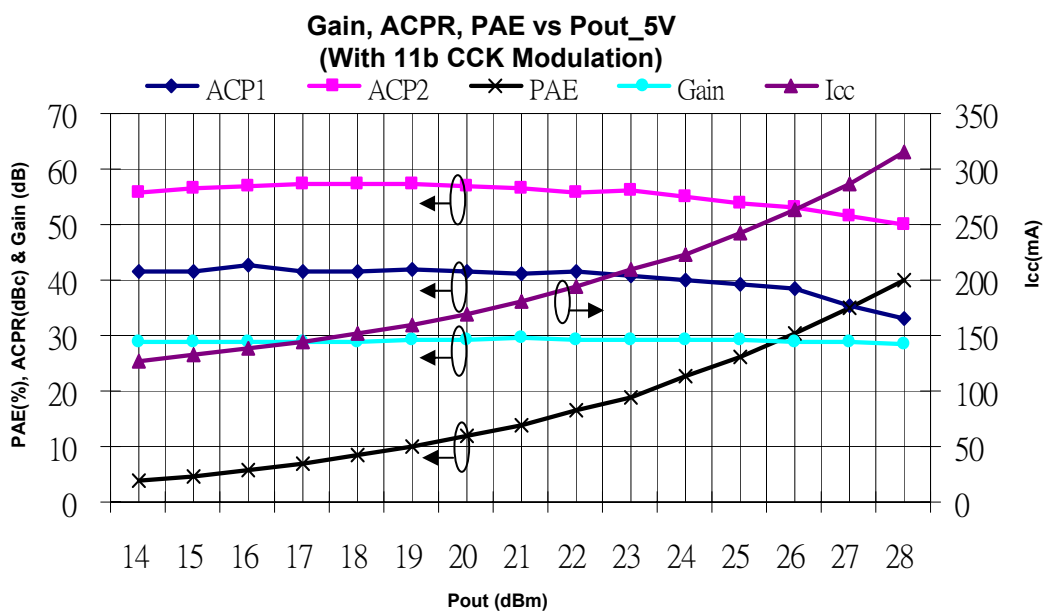

Fig. 9



2004.08.30

### Package Outline

Top View

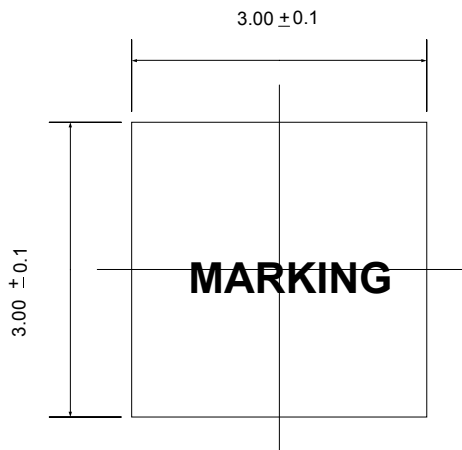

Bottom View

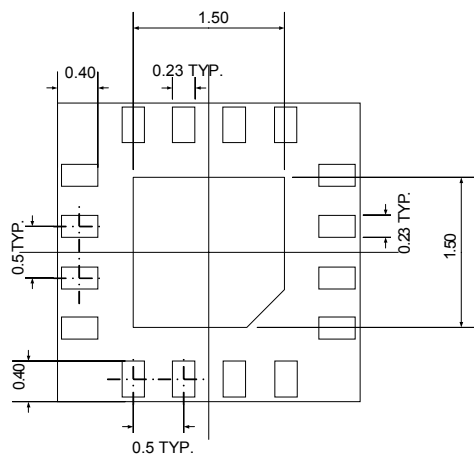

Unit: mm

Side View

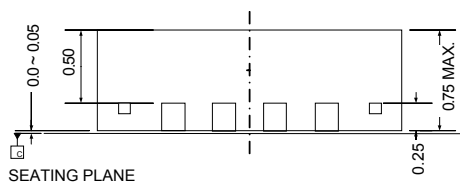

Note :

1. Dimension and tolerance conform to ASME Y14.5M-1994.
2. Refer to JEDEC STD. MO-220 WEED-2 ISSUE B

© For more detailed information, please refer to AP1093 Application Note.

For more information, please contact us at:

Sales Dept.

Tel: +886-2-2698-1022

e-mail: sales@rfintc.com

© 2003 RF Integrated Corporation. All rights reserved.

RF integrated Corp. reserves the right to make any changes to the specifications without notice.