



AP358

Low Power Dual Operational Amplifiers

■ Features

- Internally frequency compensated for unity gain
- Large dc voltage gain: 100 dB
- Very low supply current drain (500µA)-essentially independent of supply voltage
- Wide bandwidth (unity gain): 1 MHz (temperature compensated)
- Input common-mode voltage range includes ground
- Differential input voltage range equal to the power supply voltage
- Low input offset voltage: 2mV
- Wide power supply range:
Single supply: 3V to 32V
Or dual supplies: ±1.5V to ±16V
- Large output voltage swing: 0V to V⁺ - 1.5V
- 8-pin PDIP and SOP **Pb-Free** packages

■ Advantages

- Eliminates need for dual supplies
- Compatible with all forms of logic
- Two internally compensated op amps
- Power drain suitable for battery operation
- Allows direct sensing near GND and V_{OUT} also goes to GND

■ Unique Characteristics

- In the linear mode the input common-mode voltage range includes ground and the output voltage can also swing to ground, even though operated from only a single power supply voltage.
- The unity gain cross frequency is temperature compensated.
- The input bias current is also temperature compensated.

■ Pin Assignment

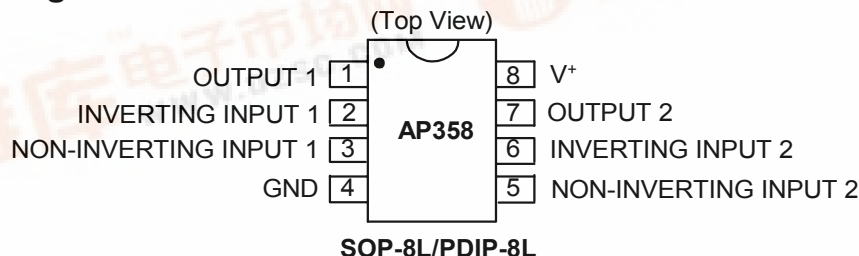

■ General Description

The AP358 series consists of two independent, high gain, internally frequency compensated operational amplifiers which were designed specifically to operate from a single power supply over a wide range of voltages. Operation from split power supplies is also possible and the low power supply current drain is independent of the magnitude of the power supply voltage.

Application areas include transducer amplifiers, dc gain blocks and all the conventional op amp circuits which now can be more easily implemented in single power supply systems. For example, the AP358 series can be directly operated off of the standard +5V power supply voltage which is used in digital systems and will easily provide the required interface electronics without requiring the additional ±15V power supplies.

■ Pin Descriptions

Pin Name	Pin #	Description
OUTPUT 1	1	Channel 1 Output
INVERTING INPUT 1	2	Channel 1 Inverting Input
NON-INVERTING INPUT 1	3	Channel 1 Non-inverting Input
GND	4	Ground
NON-INVERTING INPUT 2	5	Channel 2 Non-inverting Input
INVERTING INPUT 2	6	Channel 2 Inverting Input
OUTPUT 2	7	Channel 2 Output
V ⁺	8	Chip Supply Voltage

Low Power Dual Operational Amplifiers

■ Ordering Information

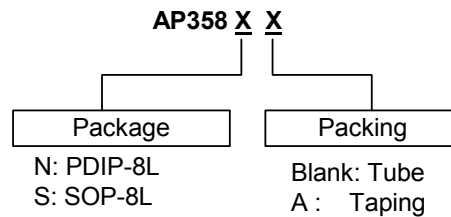

■ Block Diagram

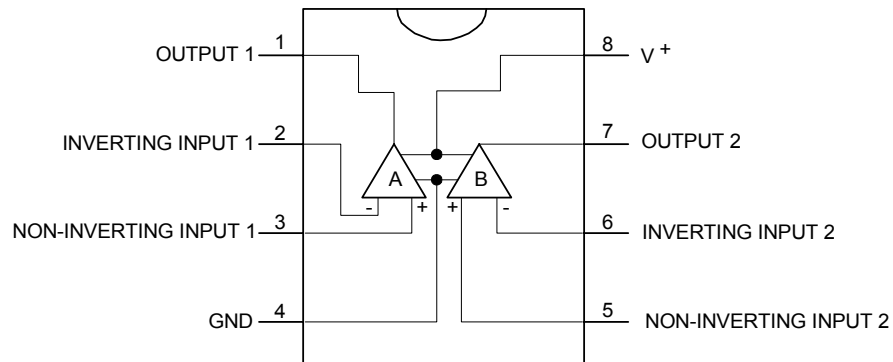

■ Voltage Controlled Oscillator (VCO)

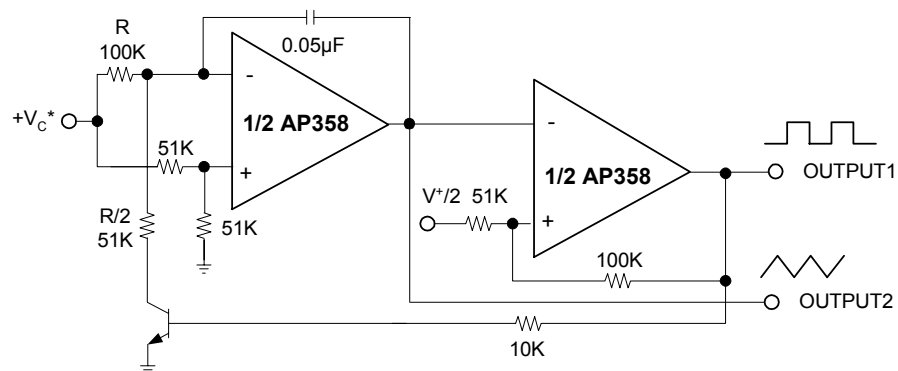



Low Power Dual Operational Amplifiers

■ Absolute Maximum Ratings

Symbol	Parameter		Rating	Unit
V_{CC}	Supply voltage		32	V
	Differential Input Voltage		32	V
V_{IN}	Input Voltage		-0.3 to +32	V
P_D	Power Dissipation (Note1)	Molded DIP	830	mW
		Small Outline Package (M)	530	
	Output Short-Circuit to GND (One Amplifier) (Note 2)	$V^+ \leq 15V$ and $T_A=25^\circ C$	Continuous	
		Input Current ($V_{IN} < -0.3V$) (Note 3)	40	mA
T_{OP}	Operating Temperature Range		0 to +70	$^\circ C$
T_{ST}	Storage Temperature Range		-65 to +150	$^\circ C$

■ Electrical Characteristics ($T_A=25^\circ C$, $V^+=+5.0V$, unless otherwise stated) (Note 4)

Symbol	Parameter	Conditions	Min.	Typ.	Max.	Unit
V_{IO}	Input Offset Voltage	(Note 5), $T_A=25^\circ C$	-	2	7	mV
I_B	Input Bias Current	$I_{IN(+)}$ or $I_{IN(-)}$, $T_A=25^\circ C$, $V_{CM}=0V$, (Note6)	-	45	250	nA
I_{IO}	Input Offset Current	$I_{IN(+)} - I_{IN(-)}$, $V_{CM}=0V$, $T_A=25^\circ C$	-	5	50	nA
V_{ICM}	Input Common-Mode Voltage Range	$V^+=30V$, (Note 7) $T_A=25^\circ C$	0	-	$V^+ - 1.5$	V
I_S	Supply Current Over Full Temperature Range	$R_L = \infty$ on All Op Amps $V^+=30V$	-	1	2	mA
		$V^+=5V$	-	0.5	1.2	
A_V	Large Signal Voltage Gain	$V^+=15V$, $T_A=25^\circ C$, $R_L > 2k\Omega$, (For $V_O=1V$ to $11V$)	25	100	-	V/mV
CMRR	Common-Mode Rejection Ratio	$T_A=25^\circ C$, $V_{CM}=0V$ to $V^+ - 1.5V$	65	85	-	dB
PSRR	Power Supply Rejection Ratio	$V^+=5V$ to $30V$, $T_A=25^\circ C$	65	100	-	dB
	Amplifier-to-Amplifier Coupling	$f=1KHz$ to $20 KHz$, $T_A=25^\circ C$ (Input Referred), (Note 8)	-	-120	-	dB



Low Power Dual Operational Amplifiers

■ Electrical Characteristics ($V^+ = +5.0V$, unless otherwise stated) (Note 4)

Symbol	Parameter	Conditions	Min.	Typ.	Max.	Unit
I_{SINK}	Output Current	Sink $V_{IN}^- = 1V, V_{IN}^+ = 0V,$ $V^+ = 15V, V_O = 2V,$ $T_A = 25^\circ C$	10	20	-	mA
		$V_{IN}^- = 1V, V_{IN}^+ = 0V,$ $V^+ = 15V, V_O = 200mV,$ $T_A = 25^\circ C$	20	70	-	μA
I_{SOURCE}	Source	$V_{IN}^+ = 1V, V_{IN}^- = 0V,$ $V^+ = 15V, V_O = 2V,$ $T_A = 25^\circ C$	20	40	-	mA
I_{SC}	Short Circuit to Ground	$T_A = 25^\circ C, (Note\ 2)$ $V^+ = 15V$	-	40	60	mA
V_{OH}	Output Voltage Swing	$(V^+ = 30V)$ $R_L = 2k\Omega, T_A = 25^\circ C$	26	-	-	V
V_{OL}		$(V^+ = 5V)$ $R_L = 10k\Omega, T_A = 25^\circ C$	27	28	-	V
		$(V^+ = 5V)$ $R_L = 10k\Omega, T_A = 25^\circ C$	-	5	20	mV

Note 1: For operating at high temperatures, the AP358 must be derated based on a $+125^\circ C$ maximum junction temperature and a thermal resistance of $120^\circ C/W$ for DIP and $189^\circ C/W$ for Small Outline package, which applies for the device soldered in a printed circuit board, operating in a still air ambient. The dissipation is the total of both amplifiers—use external resistors, where possible, to allow the amplifier to saturate or to reduce the power which is dissipated in the integrated circuit.

Note 2: Short circuits from the output to V^+ can cause excessive heating and eventual destruction. When considering short circuits to ground, the maximum output current is approximately 40mA independent of the magnitude of V^+ . At values of supply voltage in excess of +15V, continuous short-circuits can exceed the power dissipation ratings and cause eventual destruction. Destructive dissipation can result from simultaneous shorts on all amplifiers.

Note 3: This input current will only exist when the voltage at any of the input leads is driven negative. It is due to the collector-base junction of the input PNP transistors becoming forward biased and thereby acting as input diode clamps. In addition to this diode action, there is also lateral NPN parasitic transistor action on the IC chip. This transistor action can cause the output voltages of the op amps to go to the V^+ voltage level (or to ground for a large overdrive) for the time duration that an input is driven negative. This is not destructive and normal output states will re-establish when the input voltage, which was negative, again returns to a value greater than $-0.3V$ (at $25^\circ C$).

Note 4: The AP358 temperature specifications are limited to $0^\circ C \leq T_A \leq +70^\circ C$.

Note 5: $V_O \cong 1.4V, R_S = 0\Omega$ with V^+ from 5V to 30V; and over the full input common-mode range (0V to $V^+ - 1.5V$) at $25^\circ C$.

Note 6: The direction of the input current is out of the IC due to the PNP input stage. This current is essentially constant, independent of the state of the output so no loading change exists on the input lines.

Note 7: The input common-mode voltage of either input signal voltage should not be allowed to go negative by more than $0.3V$ (at $25^\circ C$). The upper end of the common-mode voltage range is $V^+ - 1.5V$ (at $25^\circ C$), but either or both inputs can go to $+32V$ without damage, independent of the magnitude of V^+ .

Note 8: Due to proximity of external components, insure that coupling is not originating via stray capacitance between these external parts. This typically can be detected as this type of capacitance increases at higher frequencies.

Low Power Dual Operational Amplifiers

■ Typical Single-Supply Circuit ($V^+ = 5.0 V_{DC}$)

Non-Inverting DC Gain (0V Output)

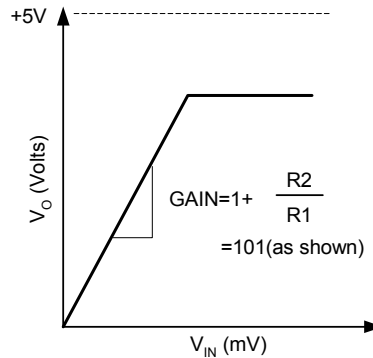
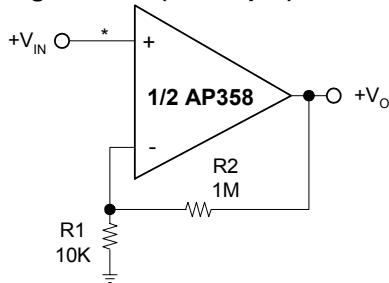

*R not needed due to temperature independent I_{IN}

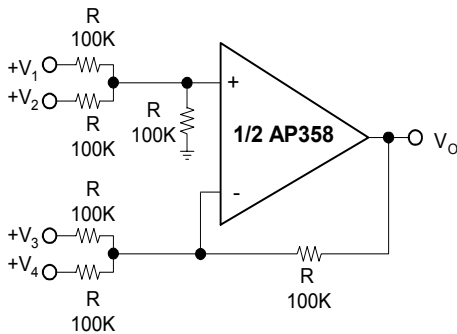

Where: $V_O = V_1 + V_2 - V_3 - V_4$
 $(V_1 + V_2) > (V_3 + V_4)$ to keep $V_O > 0 V_{DC}$

DC Summing Amplifier $(V_{IN'S} \geq 0 V_{DC} \text{ and } V_O \geq 0 V_{DC})$

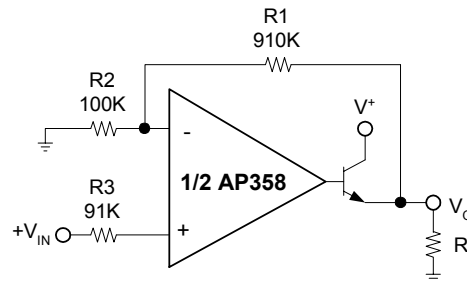

$V_O = 0 V_{DC}$ for $V_{IN} = 0 V_{DC}$
 $A_V = 10$

Power Amplifier

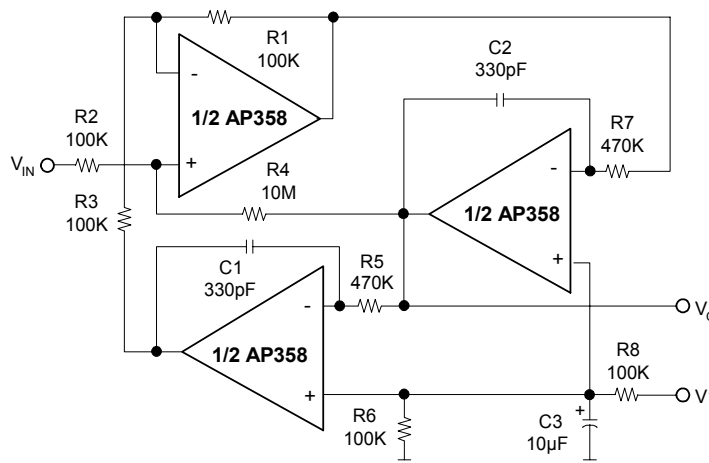

$f_o = 1\text{KHz}$
 $Q = 50$

"BI-QUAD" RC Active Bandpass Filter

Low Power Dual Operational Amplifiers

■ Typical Single-Supply Circuit ($V^+ = 5.0 V_{DC}$)

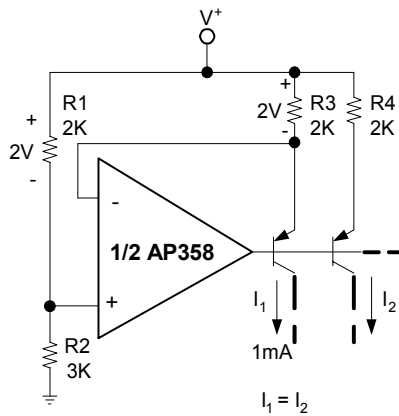

Fixed Current Sources

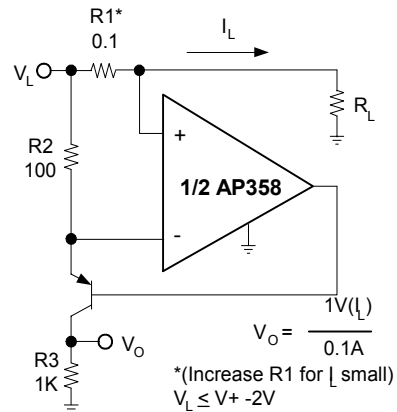

Current Monitor

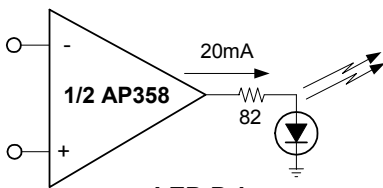

LED Driver

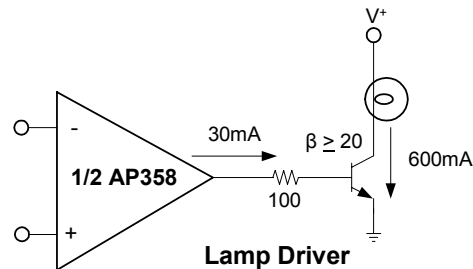

Lamp Driver

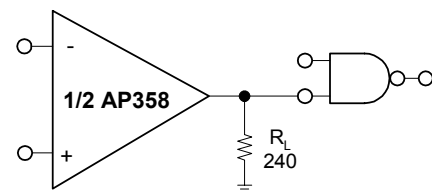

Driving TTL

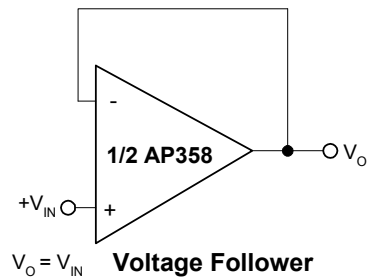

Voltage Follower

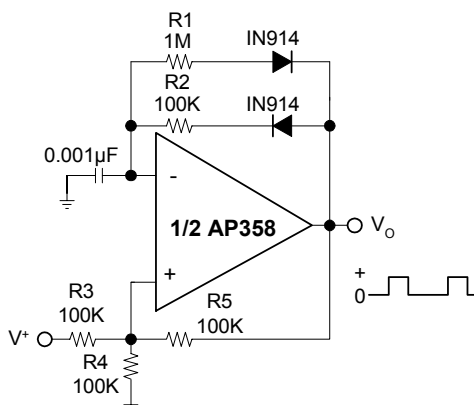

Pulse Generator

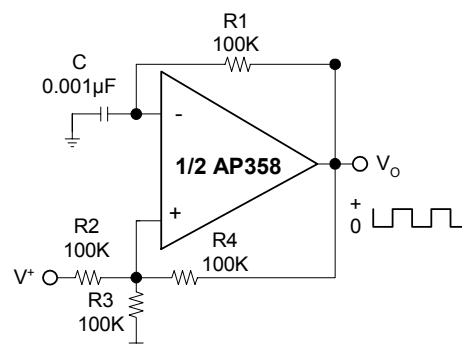

Squarewave Oscillator

Low Power Dual Operational Amplifiers

■ Typical Single-Supply Circuit ($V^+ = 5.0 V_{DC}$)

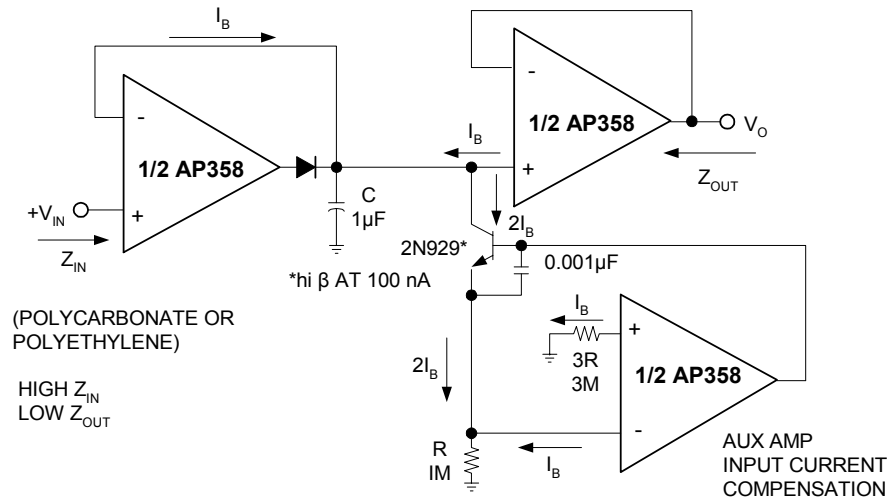

Low Drift Peak Detector

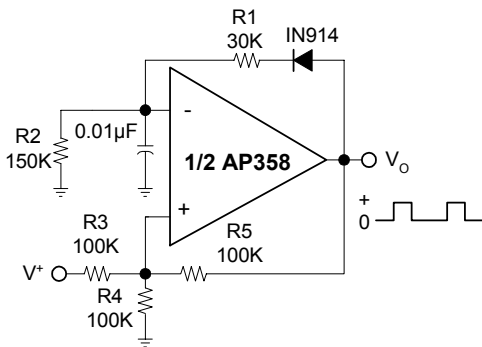

Pulse Generator

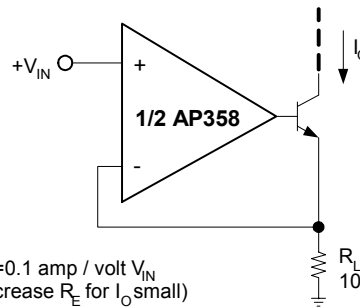

High Compliance Current Sink

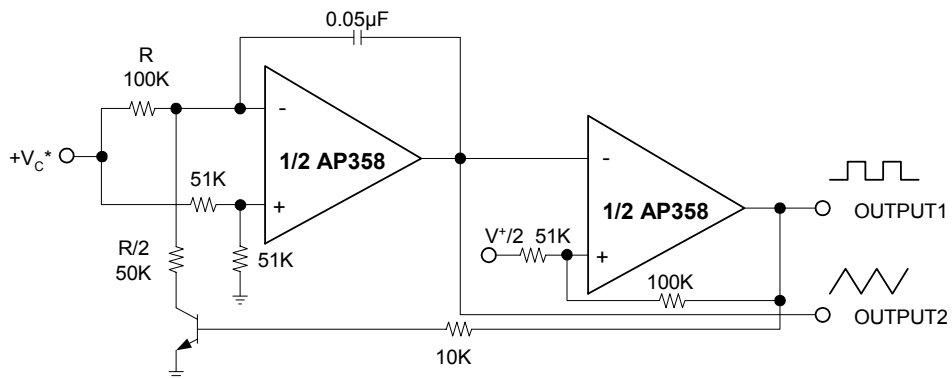

*WIDE CONTROL VOLTAGE RANGE: $0 V_{DC} \leq V_C \leq 2 (V^+ - 1.5V_{DC})$

Voltage Controlled Oscillator (VCO)

Low Power Dual Operational Amplifiers

■ Typical Single-Supply Circuit ($V^+ = 5.0 V_{DC}$)

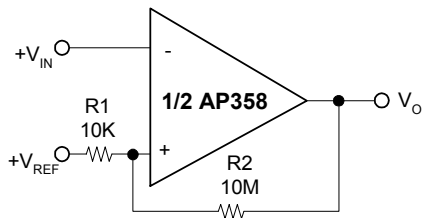

Comparator with Hysteresis

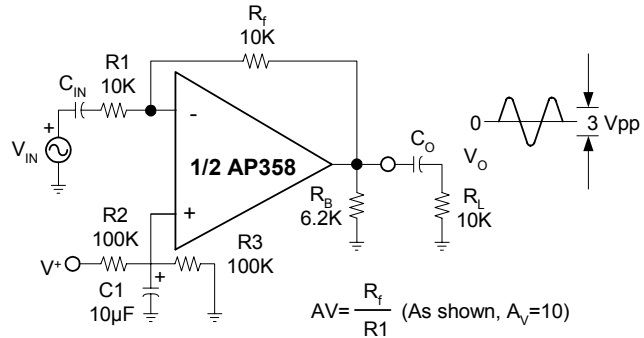

AC Coupled Inverting Amplifier

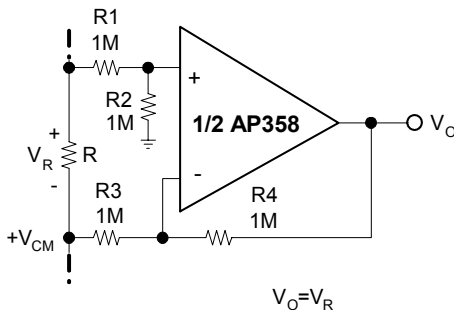

Ground Referencing a Differential Input Signal

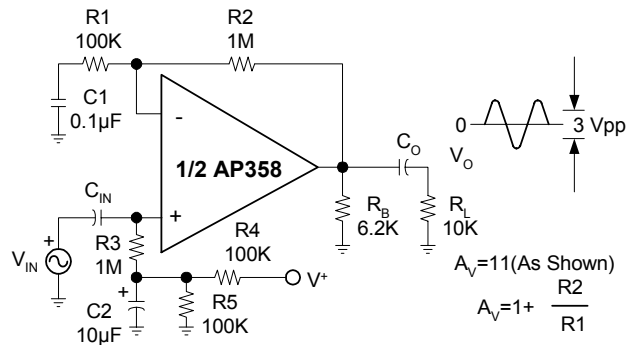

AC Coupled Non-Inverting Amplifier

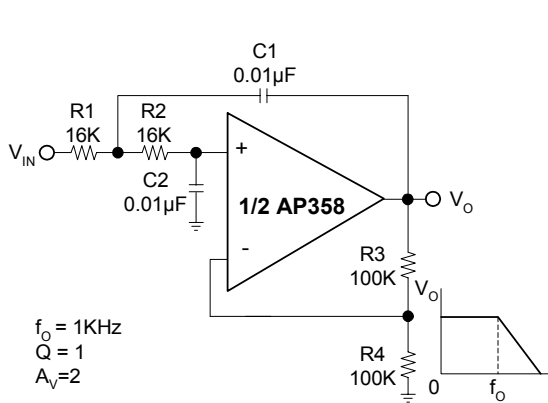

DC Coupled Low-Pass RC Active Filter

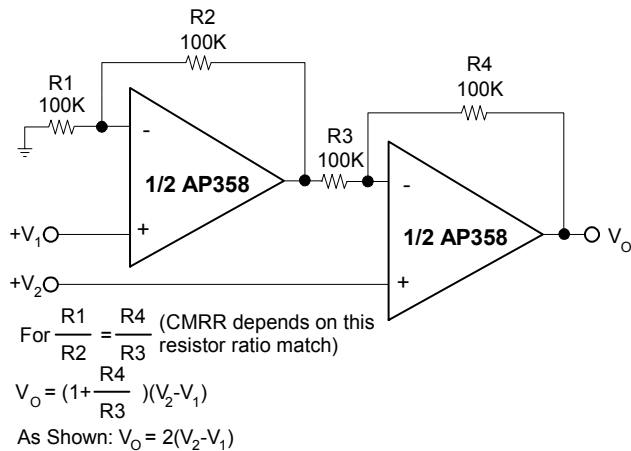

High Input Z, DC Differential Amplifier

Low Power Dual Operational Amplifiers

■ Typical Single-Supply Circuit ($V^+ = 5.0 V_{DC}$)

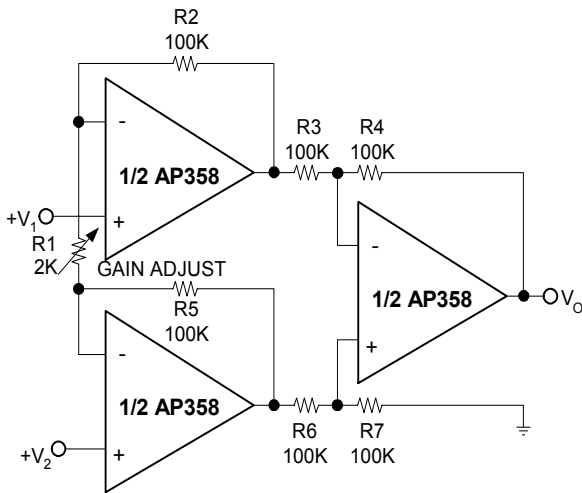
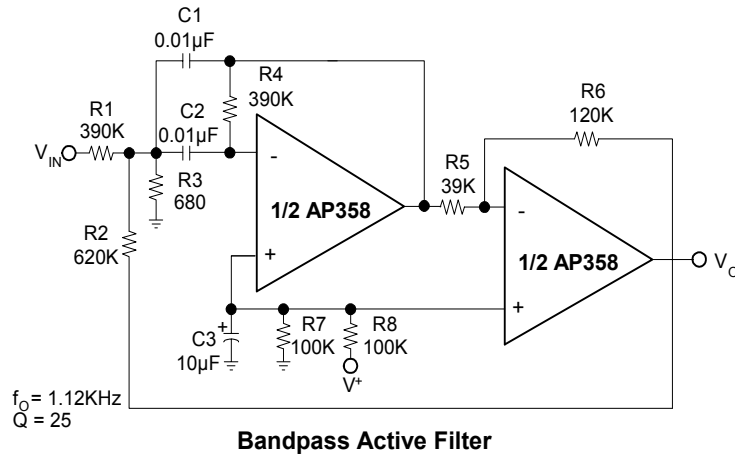

If $R1 = R5$ & $R3 = R4 = R6 = R7$ (CMRR depends on match)

$$V_o = \left(1 + \frac{2R_2}{R_1}\right) (V_2 - V_1)$$

As Shown: $V_o = 101(V_2 - V_1)$

**High Input Z Adjustable-Gain
DC Instrumentation Amplifier**

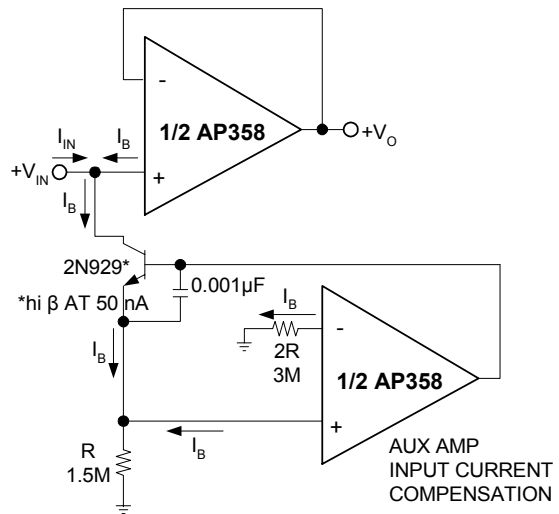

**Using Symmetrical Amplifiers to Reduce
Input Current (General Concept)**

Low Power Dual Operational Amplifiers

■ Typical Characteristics (at $T_A=25^\circ\text{C}$)

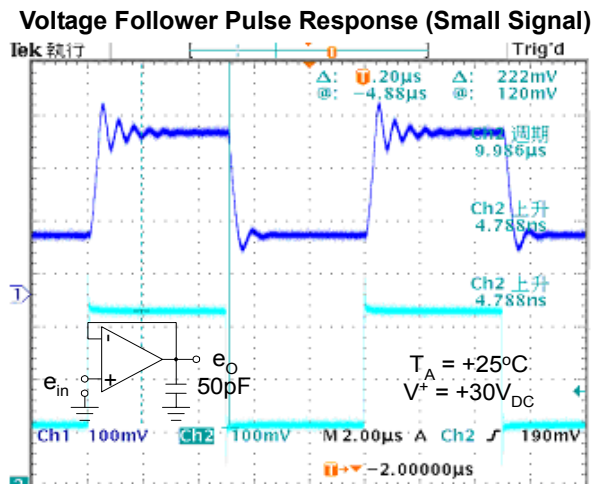
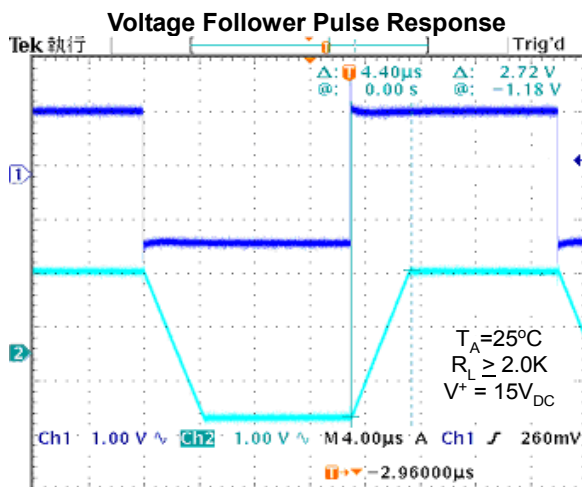
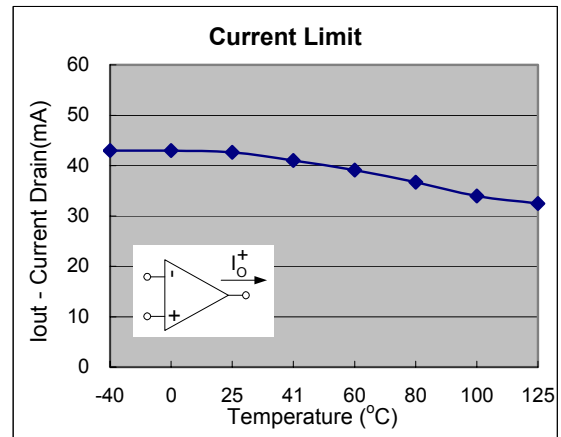
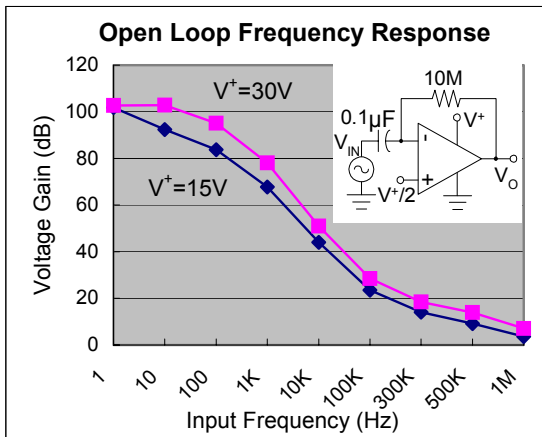
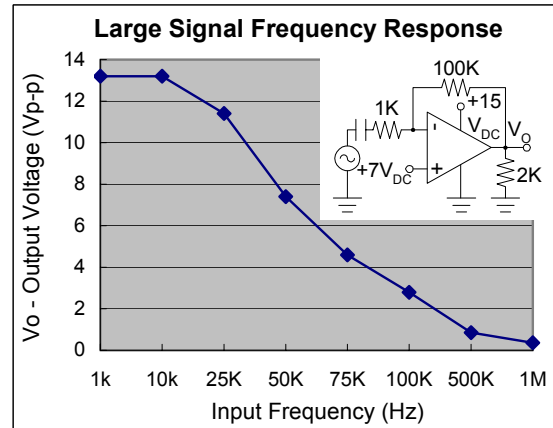
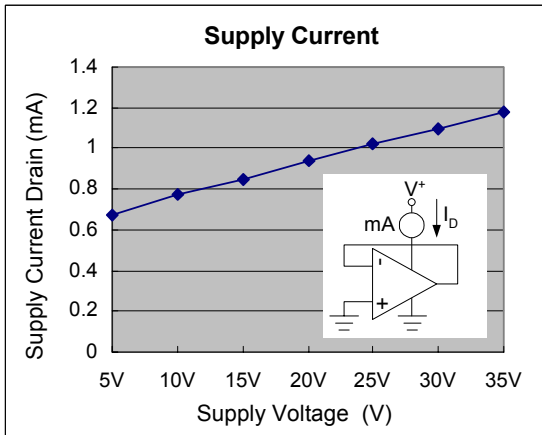



Low Power Dual Operational Amplifiers

■ Application Information

The AP358 series are op amps which operate with only a single power supply voltage, have true-differential inputs, and remain in the linear mode with an input common-mode voltage of 0 V_{DC} . These amplifiers operate over a wide range of power supply voltage with little change in performance characteristics. At 25°C amplifier operation is possible down to a minimum supply voltage of 2.3 V_{DC} .

Precautions should be taken to insure that the power supply for the integrated circuit never becomes reversed in polarity or that the unit is not inadvertently installed backwards in a test socket as an unlimited current surge through the resulting forward diode within the IC could cause fusing of the internal conductors and result in a destroyed unit.

Large differential input voltages can be easily accommodated and, as input differential voltage protection diodes are not needed, no large input currents result from large differential input voltages. The differential input voltage may be larger than V^+ without damaging the device. Protection should be provided to prevent the input voltages from going negative more than -0.3 V_{DC} (at 25°C). An input clamp diode with a resistor to the IC input terminal can be used.

To reduce the power supply current drain, the amplifiers have a class A output stage for small signal levels which converts to class B in a large signal mode. This allows the amplifiers to both source and sink large output currents. Therefore both NPN and PNP external current boost transistors can be used to extend the power capability of the basic amplifiers. The output voltage needs to raise approximately 1 diode drop above ground to bias the on-chip vertical PNP transistor for output current sinking applications.

For ac applications, where the load is capacitively coupled to the output of the amplifier, a resistor should be used, from the output of the amplifier to ground to increase the class A bias current and prevent crossover distortion. Where the load is directly coupled, as in dc applications, there is no crossover distortion.

Capacitive loads which are applied directly to the output of the amplifier reduce the loop stability margin. Values of 50pF can be accommodated using the worst-case non-inverting unity gain connection. Large closed loop gains or resistive isolation should be used if larger load capacitance must be driven by the amplifier.

The bias network of the AP358 establishes a drain current which is independent of the magnitude of the power supply voltage over the range of 3 V_{DC} to 30 V_{DC} .

Output short circuits either to ground or to the positive power supply should be of short time duration. Units can be destroyed, not as a result of the short circuit current causing metal fusing, but rather due to the large increase in IC chip dissipation which will cause eventual failure due to excessive junction temperatures. Putting direct short-circuits on more than one amplifier at a time will increase the total IC power dissipation to destructive levels, if not properly protected with external dissipation limiting resistors in series with the output leads of the amplifiers. The larger value of output source current which is available at 25°C provides a larger output current capability at elevated temperatures (see typical performance characteristics) than a standard IC op amp.

The circuits presented in the section on typical applications emphasize operation on only a single power supply voltage. If complementary power supplies are available, all of the standard op amp circuits can be used. In general, introducing a pseudo-ground (a bias voltage reference of $V^+/2$) will allow operation above and below this value in single power supply systems. Many application circuits are shown which take advantage of the wide input common-mode voltage range which includes ground. In most cases, input biasing is not required and input voltages which range to ground can easily be accommodated.

Low Power Dual Operational Amplifiers

■ Marking Information

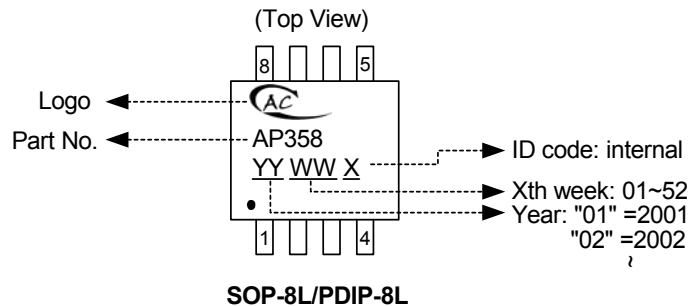

■ Package Information

(1) PDIP-8L (Plastic Dual-in-line Package)

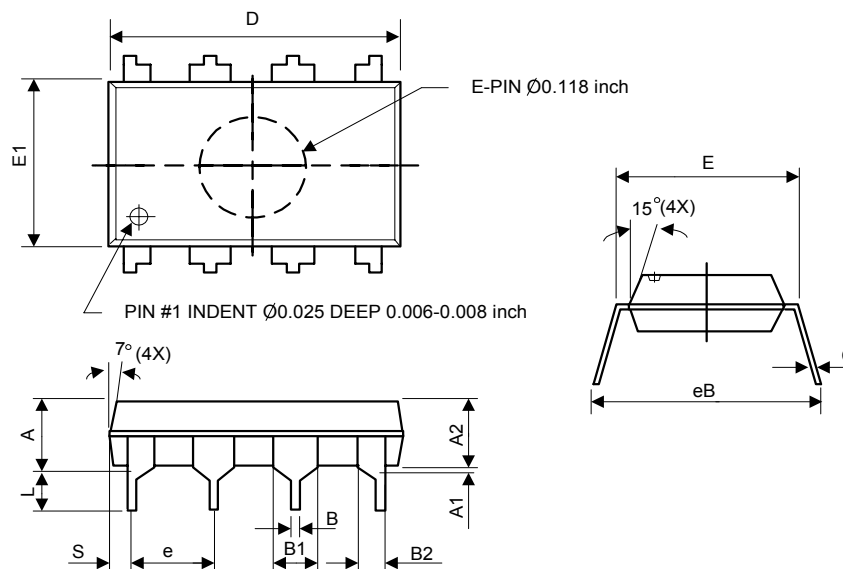

Symbol	Dimensions in millimeters			Dimensions in inches		
	Min.	Nom.	Max.	Min.	Nom.	Max.
A	-	-	5.33	-	-	0.210
A1	0.38	-	-	0.015	-	-
A2	3.1	3.30	3.5	0.122	0.130	0.138
B	0.36	0.46	0.56	0.014	0.018	0.022
B1	1.4	1.52	1.65	0.055	0.060	0.065
B2	0.81	0.99	1.14	0.032	0.039	0.045
C	0.20	0.25	0.36	0.008	0.010	0.014
D	9.02	9.27	9.53	0.355	0.365	0.375
E	7.62	7.94	8.26	0.300	0.313	0.325
E1	6.15	6.35	6.55	0.242	0.250	0.258
e	-	2.54	-	-	0.100	-
L	2.92	3.3	3.81	0.115	0.130	0.150
eB	8.38	8.89	9.40	0.330	0.350	0.370
S	0.71	0.84	0.97	0.028	0.033	0.038

Low Power Dual Operational Amplifiers

■ Package Information (Continued)

(2) SOP- 8L(JEDEC Small Outline Package)

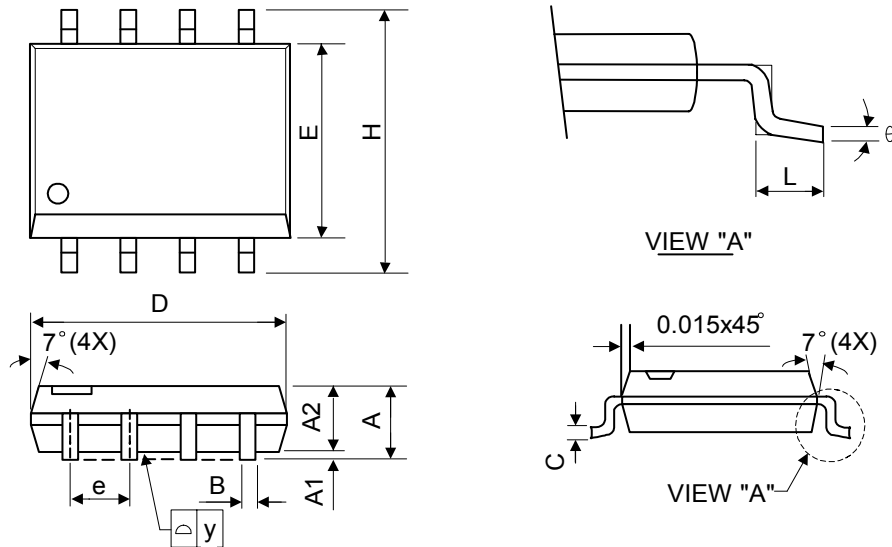

Symbol	Dimensions In Millimeters			Dimensions In Inches		
	Min.	Nom.	Max.	Min.	Nom.	Max.
A	1.40	1.60	1.75	0.055	0.063	0.069
A1	0.10	-	0.25	0.040	-	0.100
A2	1.30	1.45	1.50	0.051	0.057	0.059
B	0.33	0.41	0.51	0.013	0.016	0.020
C	0.19	0.20	0.25	0.0075	0.008	0.010
D	4.80	5.05	5.30	0.189	0.199	0.209
E	3.70	3.90	4.10	0.146	0.154	0.161
e	-	1.27	-	-	0.050	-
H	5.79	5.99	6.20	0.228	0.236	0.244
L	0.38	0.71	1.27	0.015	0.028	0.050
y	-	-	0.10	-	-	0.004
θ	0°	-	8°	0°	-	8°