

# APA2822



Dual Low-Voltage Power Amplifier

## Features

- Supply Voltage Down to 1.8V
- Low Crossover Distortion
- Low Quiescent Current
- Bridge-tied or Stereo(Single-ended) Configurations
- Both DIP-8 and SOP-8 packages available

## General Description

The APA2822 is a monolithic integrated circuit in 8-lead PDIP package. It is intended for use as dual audio power amplifier in portable cassette players, active speakers, and radios.

## Applications

- Audio Amplifiers
- Active Speakers
- Sound Cards
- Filters
- Analog Circuit

## Pin Description

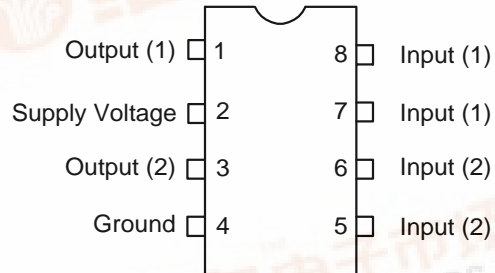

## Ordering Information

<p>APA 2822 □□-□□</p> <p>Handling Code Temp. Range Package Code</p>	<p>Package Code J : PDIP - 8      K : SOP - 8</p> <p>Temp. Range C : 0 to +70° C</p> <p>Handling Code TU : Tube</p>
---	---

## Absolute Maximum Ratings

Symbol	Parameter	Rating	Unit
$V_{CC}$	Supply Voltage	15	V
$I_O$	Peak Output Current	1	A
$V_I$	Input Voltage	15	V
$P_{TOT}$	Power Dissipation at $T_{AMB} = 50^{\circ}C$	1	W
	at $T_{CASE} = 50^{\circ}C$	1.4	
$T_{STG}, T_J$	Storage and Junction Temperature Range	-40 to +150	$^{\circ}C$

## Thermal Data

Symbol	Parameter	Rating	Unit
$R_{TH J-AMB}$	Thermal Resistance Junction-Ambient	Max. 100	$^{\circ}C/W$
$R_{TH J-CASE}$	Thermal Resistance Junction-Pin	Max. 70	$^{\circ}C/W$

## Electrical Characteristics ( $V_S = 6V$ , $T_A = 25^{\circ}C$ , unless otherwise specified)

Symbol	Parameter	Test Conditions	APA2822			Unit
			Min.	Typ.	Max.	
STEREO (test circuit of Figure 1)						
$V_S$	Supply Voltage		1.8		15	V
$V_O$	Quiescent Output Voltage	$V_S = 3V$		2.7 1.2		V
$I_D$	Quiescent Drain Current			6		mA
$I_B$	Input Bias Current			100		nA
$P_O$	Output Power ( $f = 1kHz$ , $d = 10\%$ )	$R_L = 32\Omega$ $V_S = 9V$		300		mW
		$V_S = 6V$		120		
		$V_S = 4.5V$		60		
		$V_S = 3V$		20		
		$V_S = 2V$		5		
		$R_L = 16\Omega$ $V_S = 6V$		220		
		$R_L = 8\Omega$ $V_S = 9V$		1000		
	$V_S = 6V$		380			
	$R_L = 4\Omega$ $V_S = 6V$		650			
	$V_S = 4.5V$		320			
	$V_S = 3V$		110			

**Electrical Characteristics Cont.** ( $V_S = 6V$ ,  $T_A = 25^\circ C$ , unless otherwise specified)

Symbol	Parameter	Test Conditions	APA2822			Unit
			Min.	Typ.	Max.	
d	Distortion (f = 1kHz)	$R_L = 32\Omega$ $P_O = 40mW$ $R_L = 16\Omega$ $P_O = 75mW$ $R_L = 8\Omega$ $P_O = 150mW$		0.2 0.2 0.2		%
STEREO (test circuit of Figure 1)						
$G_V$	Closed Loop Voltage Gain	f = 1kHz		39		dB
$\Delta G_V$	Channel Balance				$\pm 1$	dB
$R_I$	Input Resistance	f = 1kHz	100			k $\Omega$
$e_N$	Total Input Noise	$R_S = 10k\Omega$ B = 22Hz to 22kHz		2.5		$\mu V$
SVR	Supply Voltage Rejection	f = 100Hz, C1 = C2 = 100 $\mu F$		30		dB
$C_s$	Channel Separation	f = 1kHz		50		
BRIDGE (test circuit of Figure 2)						
$V_S$	Supply Voltage		1.8		15	V
$I_D$	Quiescent Drain Current	$R_L = 8\Omega$		6	9	mA
$V_{OS}$	Output Offset Voltage (between the outputs)	$R_L = 8\Omega$			$\pm 50$	mV
$I_B$	Input Bias Current			100		nA
$P_O$	Output Power (f = 1kHz, d = 10%)	$R_L = 32\Omega$ $V_S = 9V$ $V_S = 6V$ $V_S = 4.5V$ $V_S = 3V$ $V_S = 2V$ $R_L = 16\Omega$ $V_S = 9V$ $V_S = 6V$ $V_S = 3V$ $R_L = 8\Omega$ $V_S = 6V$ $V_S = 4.5V$ $V_S = 3V$ $R_L = 4\Omega$ $V_S = 4.5V$ $V_S = 3V$ $V_S = 2V$		1000 400 200 65 8 2000 800 120 1350 700 220 1000 350 80		mW
d	Distortion	$P_O = 0.5W$ , $R_L = 8\Omega$ , f = 1kHz		0.2		%
$G_V$	Closed Loop Voltage Gain	f = 1kHz		39		dB
$R_I$	Input Resistance	f = 1kHz	100			k $\Omega$
$e_N$	Total Input Noise	$R_S = 10k\Omega$ , B = 22Hz to 22kHz		3		$\mu V$
SVR	Supply Voltage Rejection	f = 100Hz		30		dB
B	Power Bandwidth (-3dB)	$R_L = 8\Omega$ , $P_O = 1W$			120	kHz

## Test Information

Figure 1 : Test Circuit (Stereo)

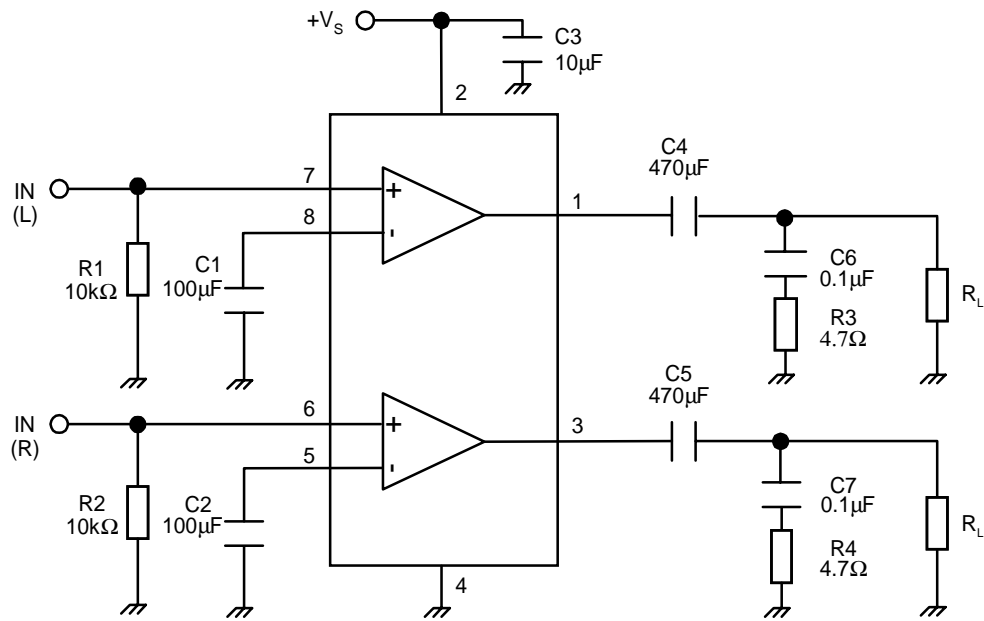
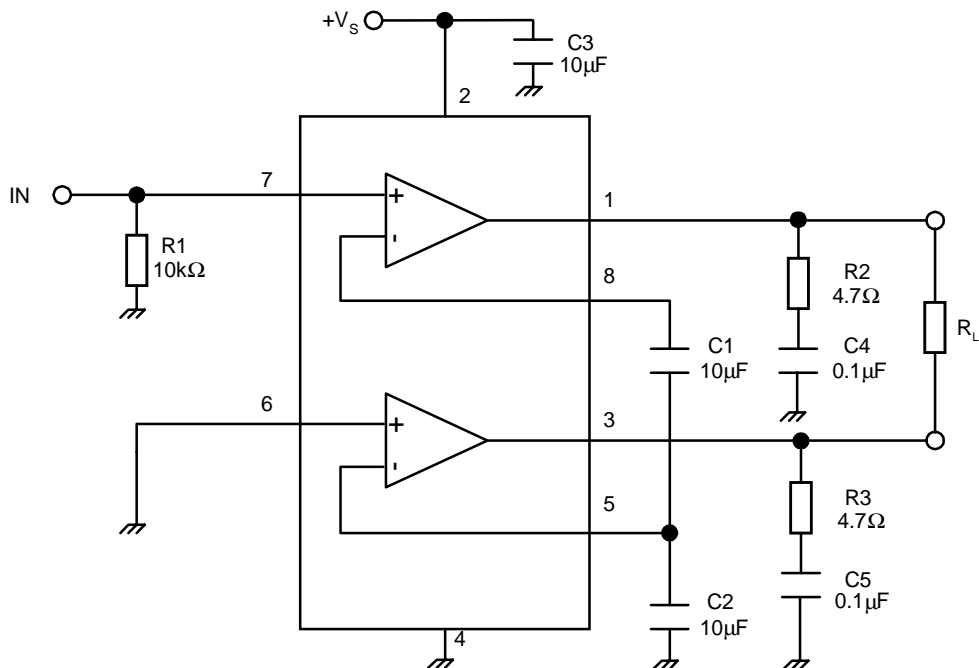
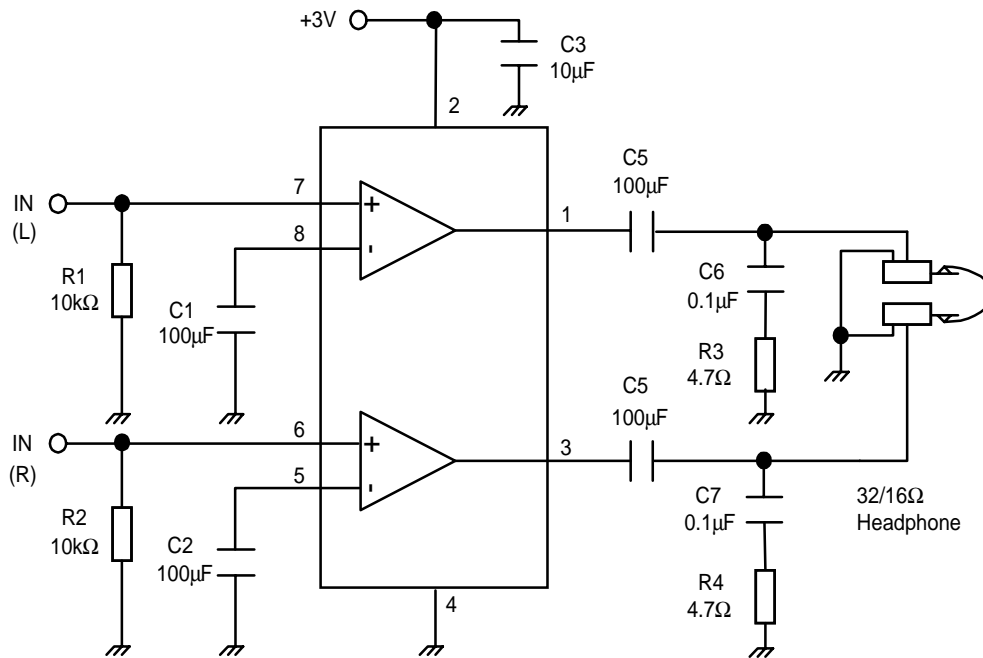

Figure2 : Test Circuit (Bridge)



## Test Information

Figure 3 : Typical Application in Portable Players



## Customer Service

### Anpec Electronics Corp.

Head Office :

5F, No. 2 Li-Hsin Road, SBIP,  
Hsin-Chu, Taiwan, R.O.C.  
Tel : 886-3-5642000  
Fax : 886-3-5642050

Taipei Branch :

7F, No. 137, Lane 235, Pac Chiao Rd.,  
Hsin Tien City, Taipei Hsien, Taiwan, R.  
O. C.  
Tel : 886-2-89191368  
Fax : 886-2-89191369

## Packaging Information

PDIP-8 pin ( Reference JEDEC Registration MS-001)

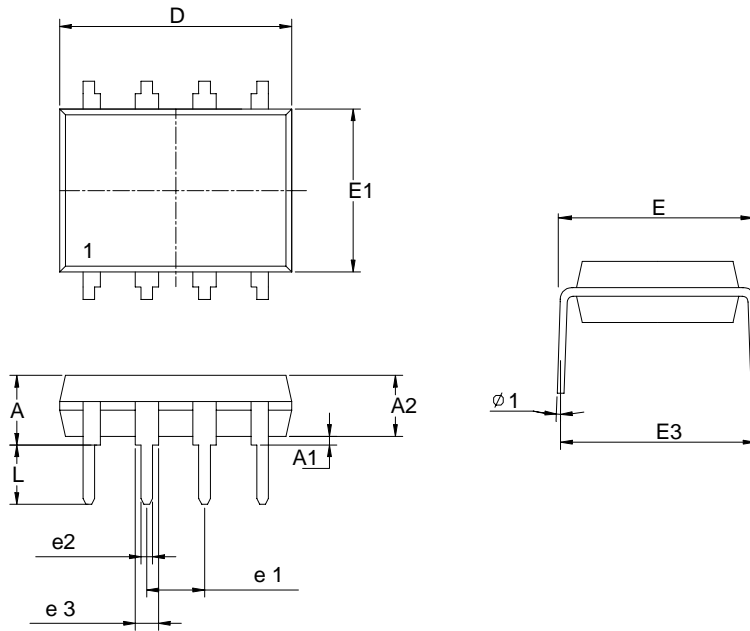

Dim	Millimeters		Inches	
	Min.	Max.	Min.	Max.
A		5.33		0.210
A1	0.38		0.015	
A2	2.92	3.68	0.115	0.145
D	9.02	10.16	0.355	0.400
e1	2.54BSC		0.100BSC	
e2	0.36	0.56	0.014	0.022
e3	1.14	1.78	0.045	0.070
E	7.62 BSC		0.300 BSC	
E1	6.10	7.11	0.240	0.280
E3		10.92		0.430
L	2.92	3.81	0.115	0.150
∅ 1	15°		15°	

## Packaging Information

SOP-8 pin ( Reference JEDEC Registration MS-012)

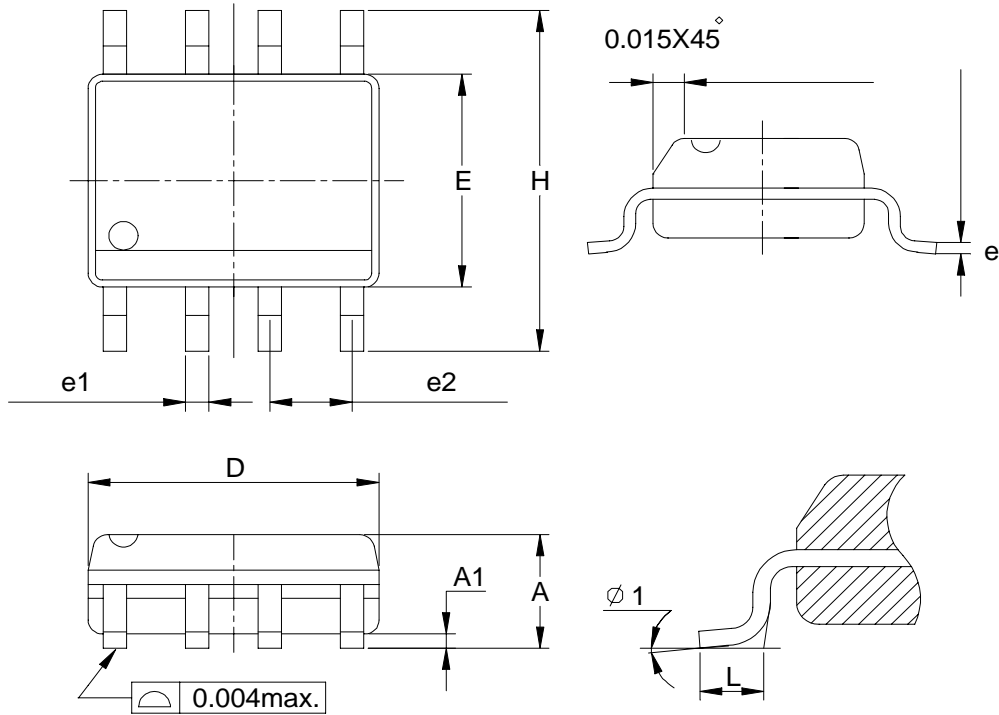

Dim	Millimeters		Inches	
	Min.	Max.	Min.	Max.
A	1.35	1.75	0.053	0.069
A1	0.10	0.25	0.004	0.010
D	4.80	5.00	0.189	0.197
E	3.80	4.00	0.150	0.157
H	5.80	6.20	0.228	0.244
L	0.40	1.27	0.016	0.050
e1	0.33	0.51	0.013	0.020
e2	1.27BSC		0.50BSC	
$\phi 1$	0°	8°	0°	8°

## Physical Specifications

Terminal Material	Solder-Plated Copper (Solder Material : 90/10 or 63/37 SnPb)
Lead Solderability	Meets EIA Specification RSI86-91, ANSI/J-STD-002 Category 3.
Packaging	2500 devices per reel

## Reflow Condition (IR/Convection or VPR Reflow)

Reference JEDEC Standard J-STD-020A APRIL 1999

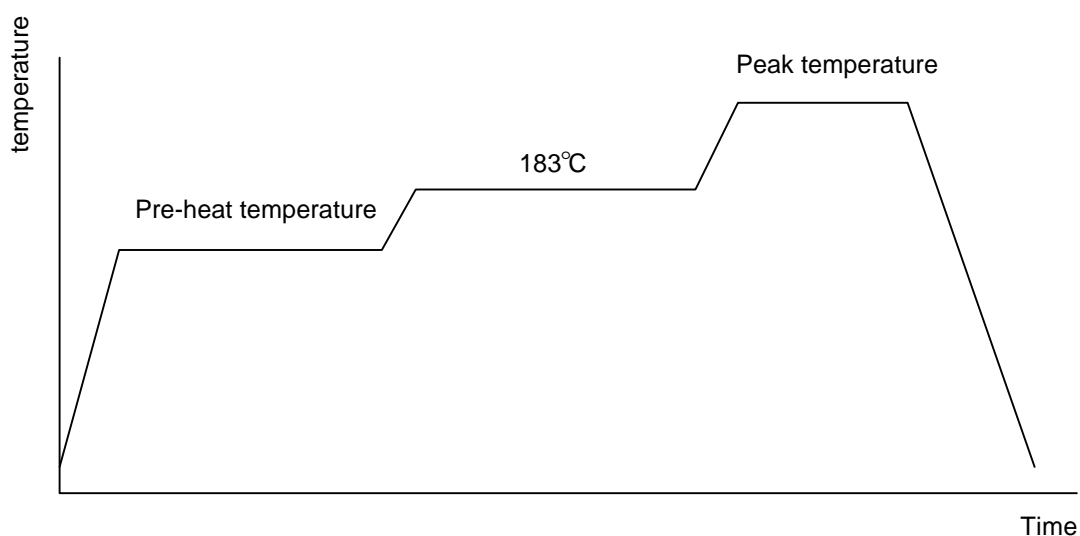

## Classification Reflow Profiles

	Convection or IR/ Convection	VPR
Average ramp-up rate(183°C to Peak)	3°C/second max.	10 °C /second max.
Preheat temperature 125 ± 25°C)	120 seconds max	
Temperature maintained above 183°C	60 – 150 seconds	
Time within 5°C of actual peak temperature	10 –20 seconds	60 seconds
Peak temperature range	220 +5/-0°C or 235 +5/-0°C	215-219°C or 235 +5/-0°C
Ramp-down rate	6 °C /second max.	10 °C /second max.
Time 25°C to peak temperature	6 minutes max.	

## Package Reflow Conditions

pkg. thickness ≥ 2.5mm and all bgas	pkg. thickness < 2.5mm and pkg. volume ≥ 350 mm <sup>3</sup>	pkg. thickness < 2.5mm and pkg. volume < 350mm <sup>3</sup>
Convection 220 +5/-0 °C		Convection 235 +5/-0 °C
VPR 215-219 °C		VPR 235 +5/-0 °C
IR/Convection 220 +5/-0 °C		IR/Convection 235 +5/-0 °C



## Reliability test program

Test item	Method	Description
SOLDERABILITY	MIL-STD-883D-2003	245°C , 5 SEC
HOLT	MIL-STD-883D-1005.7	1000 Hrs Bias @ 125 °C
PCT	JESD-22-B, A102	168 Hrs, 100 % RH , 121°C
TST	MIL-STD-883D-1011.9	-65°C ~ 150°C, 200 Cycles
ESD	MIL-STD-883D-3015.7	VHBM > 2KV, VMM > 200V
Latch-Up	JESD 78	10ms , I <sub>tr</sub> > 100mA

## Carrier Tape & Reel Dimensions

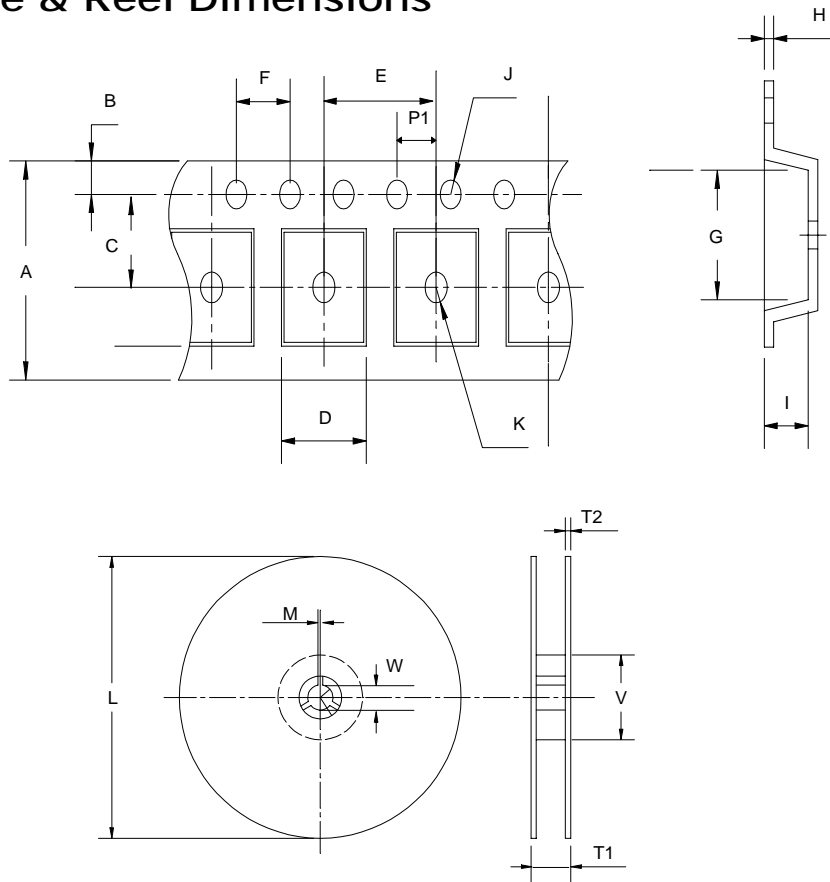

<b>Application</b>	A	E	B	C	J	K	F	P1	D
<b>SOP 8N</b>	12 + 0.3 12 - 0.1	8.0 ± 0.1	1.75 ± 0.1	5.5 ± 0.1	1.55 ± 0.1	1.5 ± 0.25	4.0 ± 0.1	2.0 ± 0.1	6.4 ± 0.1
<b>Application</b>	G	I	H	L	V	W	M	T1	T2
<b>SOP 8N</b>	5.2 ± 0.1	2.1 ± 0.1	0.3 ± 0.013	330 ± 1	100 ± 1	13 + 0.5 13 - 0.1	2.2 ± 0.1	12.5 ± 0.5	2.0 ± 0.2

(mm)

## Cover Tape Dimensions

<b>Carrier Width</b>	12
<b>Cover Tape Width</b>	9.3

(mm)