

APC207/208



Rail to Rail Output CMOS Single Operating Amplifier

Features

- Operating Voltage Single Supply 3V to 6V
- Low Input current 2pA
- Rail to Rail Output Swing
- Push-Pull Output Driving
- High Output Current Drive 310mA
- Bandwidth:7MHz
- Wide Temperature Range
- Available in the SOT23-5 Package
- Single version of APC308

Applications

- Amplifiers
- Filters
- Analog circuit

General Description

The APC207/208 brings performance and economy with high gain, CMOS operating amplifier, combining rail to rail output range with large output current. It provides a low input bias current 2pA.

The output swing of the amplifier, guaranteed for loads down to 1kΩ and output current to an 10Ω load from a 5V power supply. APC207/208 designed to operating at 3V is especially well-suited for low voltage application. The APC207/208 is offered in the space saving SOT23-5 package.

Ordering Information

<p>APC207/208 □□-□□</p> <p>Handling Code</p> <p>Temp. Range</p> <p>Package Code</p>	<p>Package Code B : SOT23-5</p> <p>Temp. Range I : - 40 to 85° C</p> <p>Handling Code TR : Tape & Reel</p>
---	--

Block Diagram

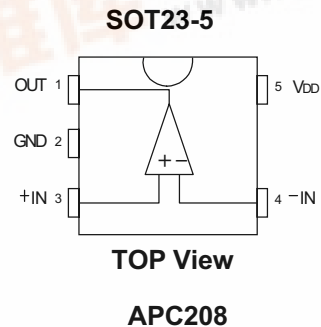
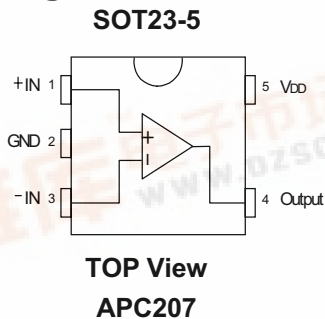

ANPEC reserves the right to make changes to improve reliability or manufacturability without notice, and advise customers to obtain the latest version of relevant information to verify before placing orders.

Absolute Maximum Ratings

Symbol	Parameter	Rating	Unit
V _{DD}	Supply Voltage	7	V
T _{SC(O)}	Output Short-circuit duration, at T _A =25°C, P _{TOT} =1W	20	S
T _A	Operating Ambient Temperature range	-40 to 85	°C
T _J	Maximum Junction Temperature	150	°C
T _{STG}	Storage Temperature Range	-65 to +150	°C
T _S	Soldering Temperature, 10 seconds	260	°C
V _{ESD}	Electrostatic Discharge	-3000 to 3000*1	V

Note : *1. Human body model : C=100pF , R=1500Ω , 3 positive pulses plus 3 negative pulses

Thermal Characteristics

Symbol	Parameter	Value	Unit
R _{THJA}	Thermal Resistance from Junction to Ambient in Free Air SOT23	357	K/W

Electrical Characteristics

V_{DD}=5V , T_A=25°C (unless otherwise noted)

Symbol	Parameter	Condition	Min.	Typ.	Max.	Unit
V _{os}	Input Offset Voltage	T _a =25°C		4	10	mV
		-25°C<T _a <75°C		5		mV
I _{bias}	Input Bias Current	T _a =25°C		2		pA
V _{icm}	Input Common Mode Voltage Range	T _a =25°C	0		V _{DD} -0.8	V
R _{IN}	Input Resistance			5		MΩ
V _o	Output Voltage Swing	R _L =2kΩ	0		5	V
V _{oh}	Output Voltage High	R _L =10kΩ, -25°C<T _a <75°C		5		V
V _{ol}	Output Voltage Low	R _L =10kΩ, -25°C<T _a <75°C		0		V
I _{out}	Output Current Source	V _o =4.5V		-310		mA
	Output Current Sink	V _o =0.5V		370		mA
CMRR	Common Mode Rejection Ratio			-80		dB

Electrical Characteristics Cont.

$V_{DD}=5V$, $T_A=25^\circ C$ (unless otherwise noted)

Symbol	Parameter	Condition	Min.	Typ.	Max.	Unit
PSRR	Supply Voltage Rejection Ratio	$V_{rr}=100mV_{pp}$, $f_{in}=100Hz, R_L=2k\Omega$		-50		dB
A_v	Large Signal Voltage Gain			85		dB
GBW	Gain Bandwidth Product			7		MHz
SR	Slew Rate			5.6		V/ μs
I_{cc}	Supply Current	$-25^\circ C < T_a < 75^\circ C$		2.0	4	mA
		$2.4V < V_{cc} < 6V$, $T_a=25^\circ C$		2.5	5	mA

Typical Characteristics

Supply Current vs Supply Voltage

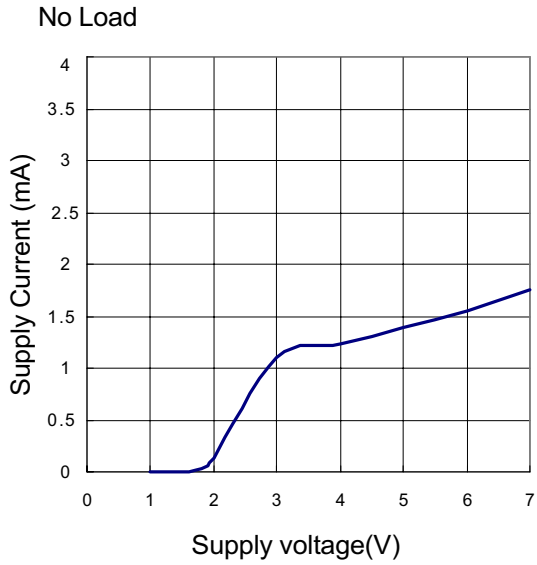

Supply Current vs Temperature

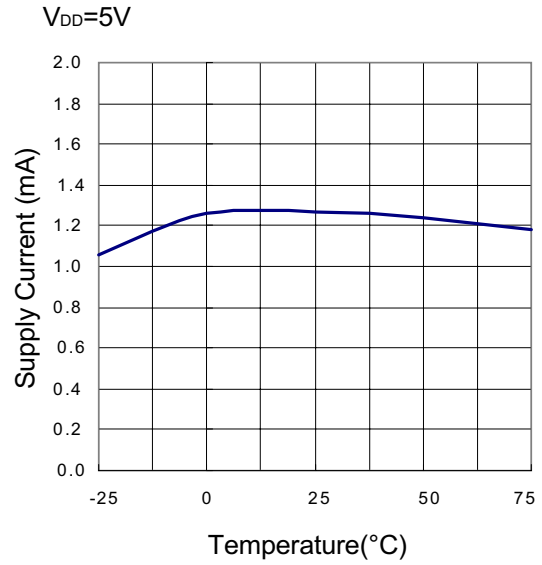

Input Offset Voltage vs Temperature

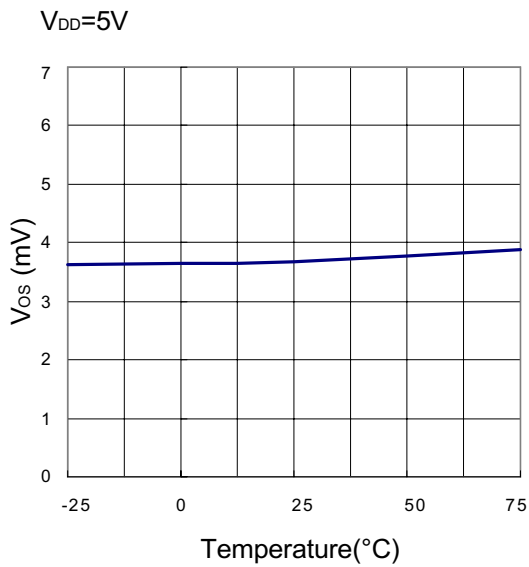

Input Common Mode Voltage vs Supply Voltage

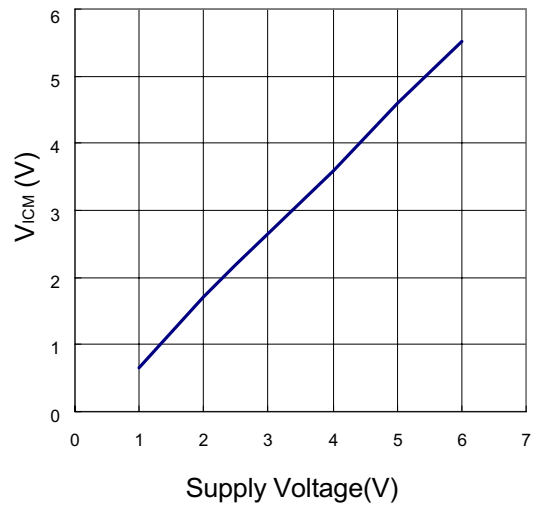

Typical Characteristics

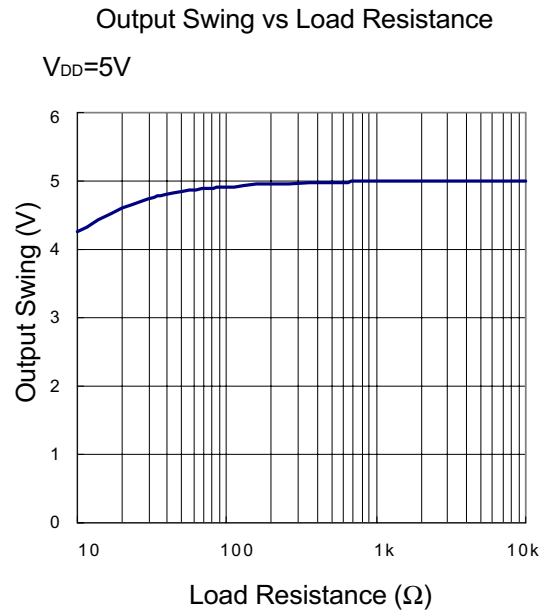
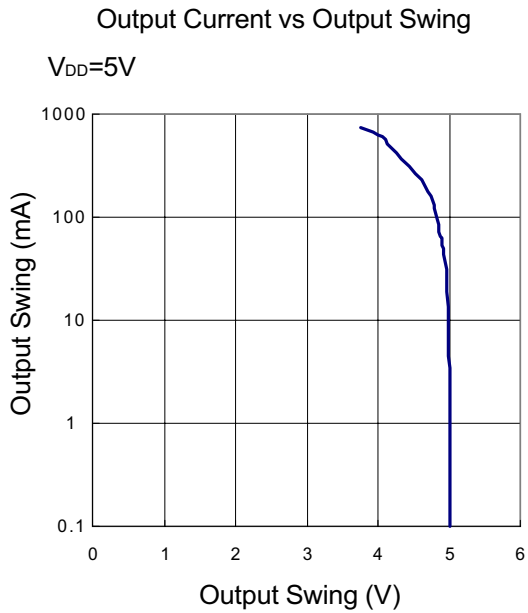
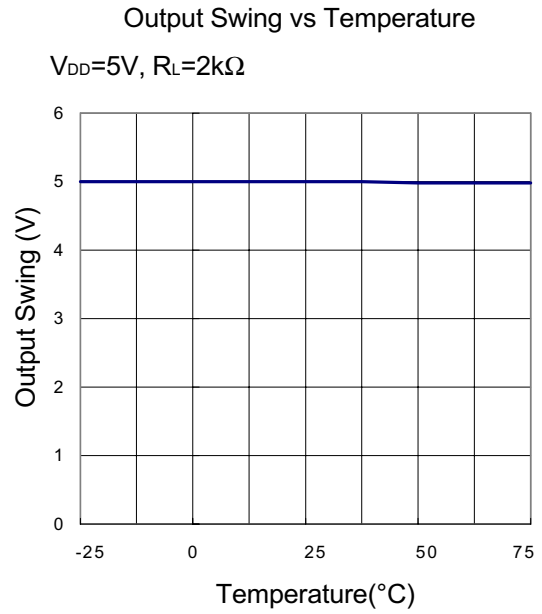
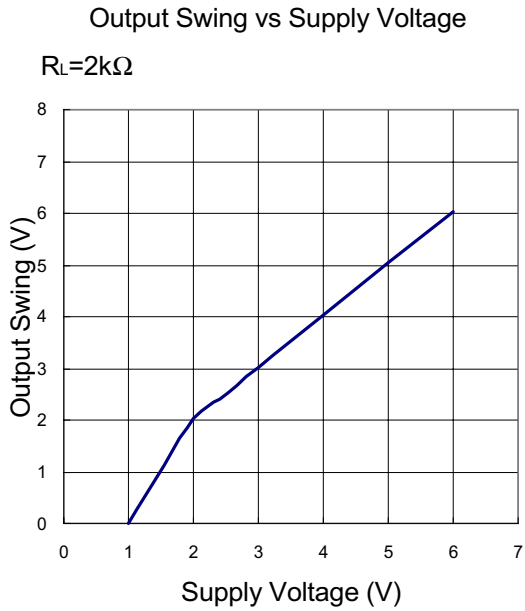

Typical Characteristics

Sink Current vs Output Voltage

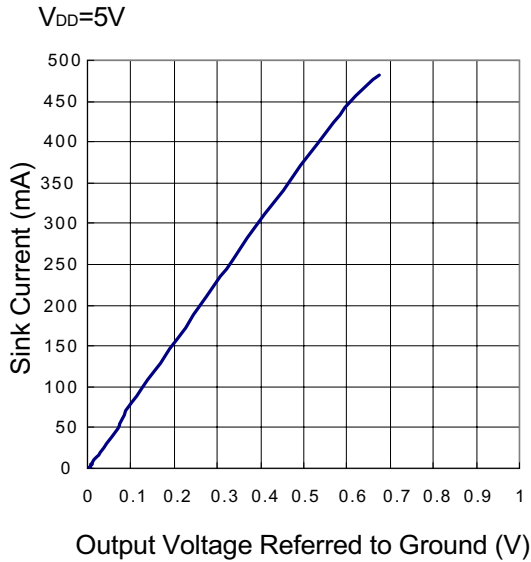

Source Current vs Output Voltage

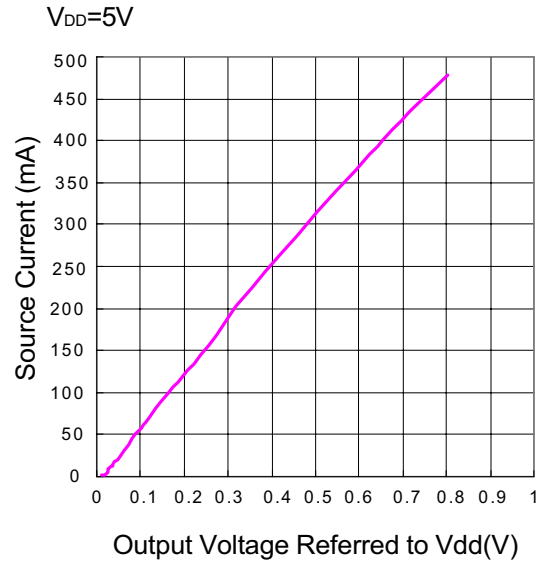

Large Signal Voltage Gain vs Frequency

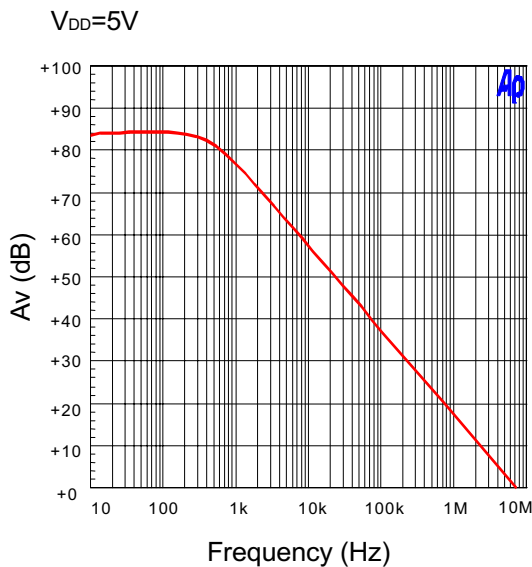

Large Signal Frequency Response

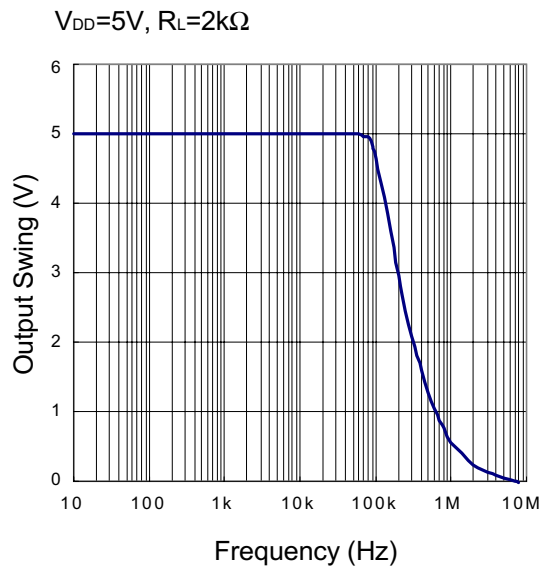

Typical Characteristics

Large Signal Voltage Gain vs Supply Voltage

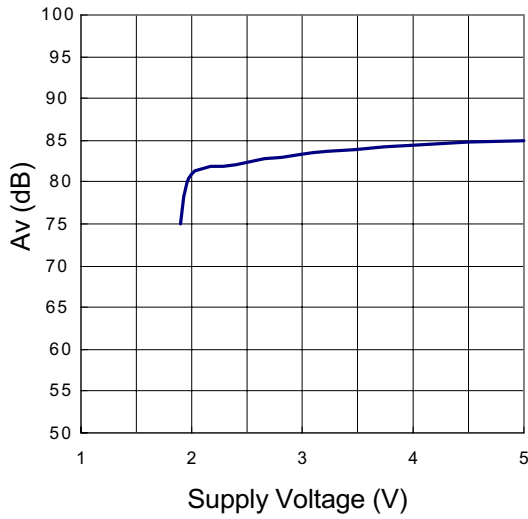

CMRR vs Frequency

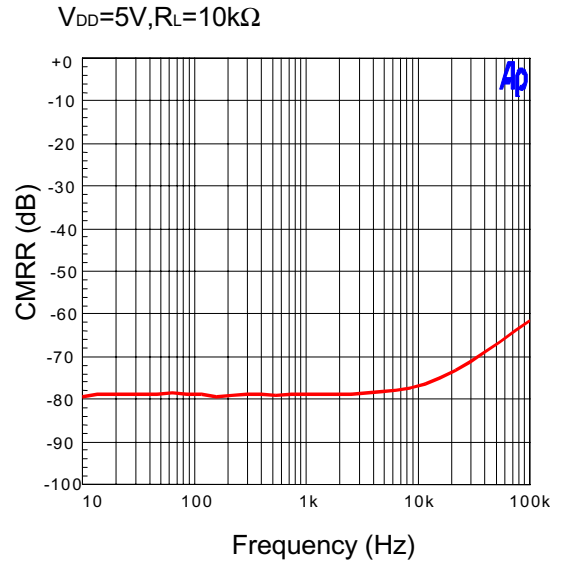

PSRR vs Frequency

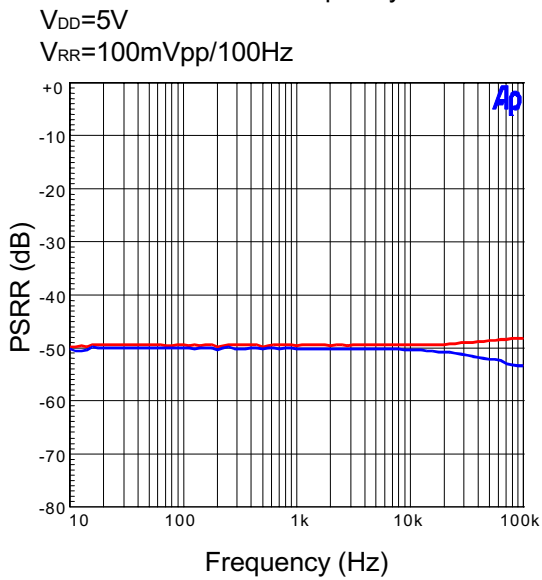

Voltage Follower Pulse Response

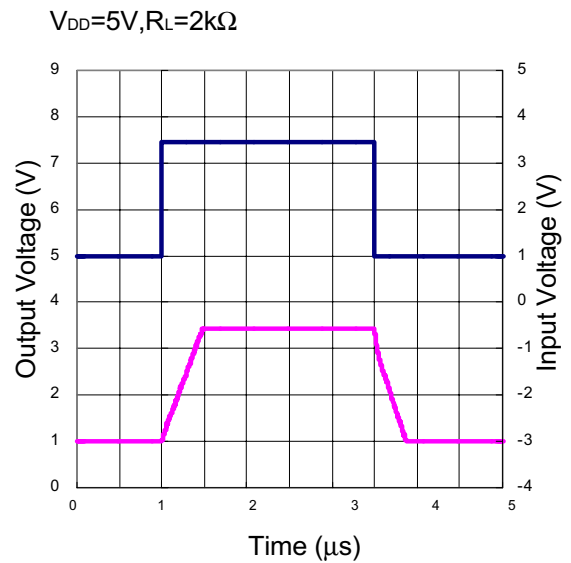

Typical Characteristics

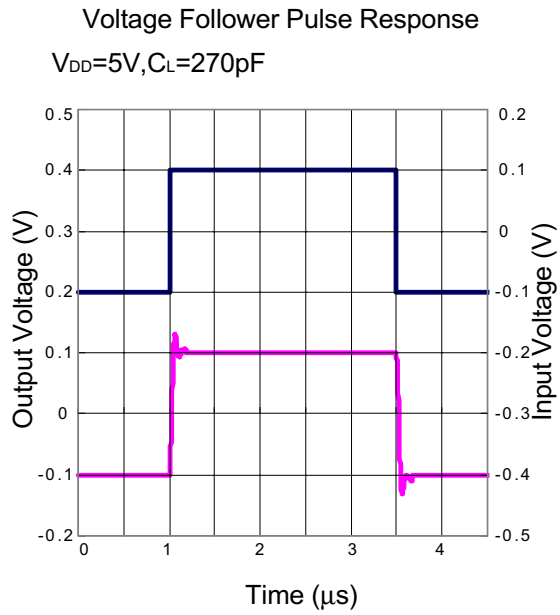

Packaging Information

SOT-23-5

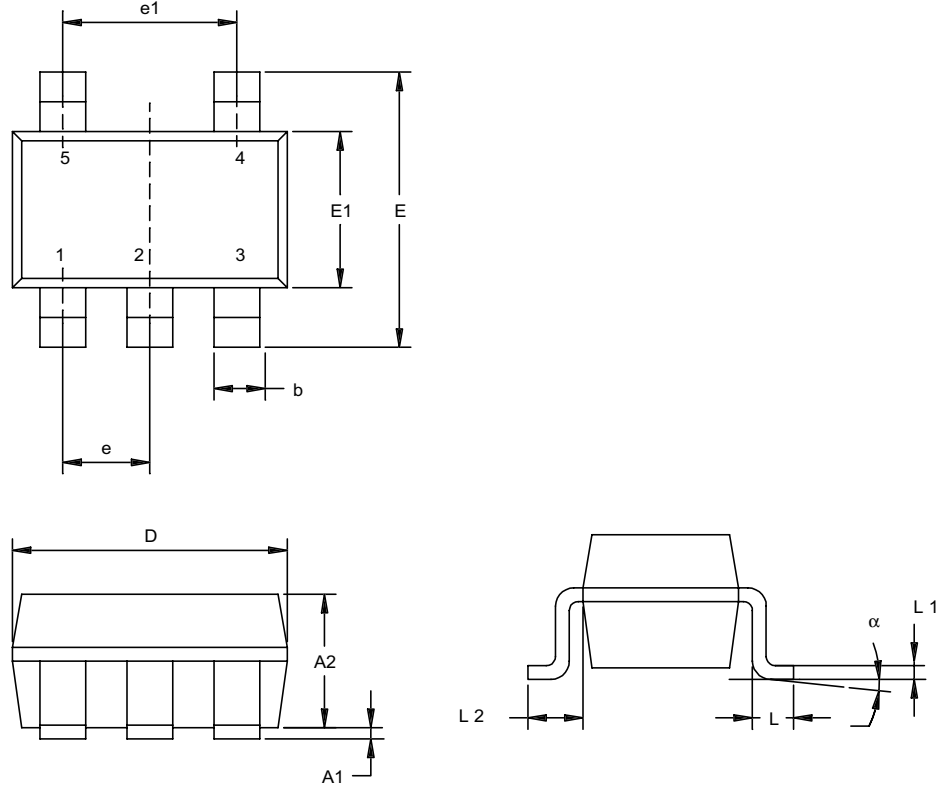

Dim	Millimeters		Inches	
	Min.	Max.	Min.	Max.
A 1	0.00	0.15	0.000	0.006
A 2	0.90	1.30	0.035	0.051
b	0.30	0.50	0.0118	0.020
D	2.70	3.10	0.106	0.122
e	0.95 (TYP)		0.037 (TYP)	
e_1	1.90 (TYP)		0.075 (TYP)	
E	2.6	3.00	0.102	0.118
E_1	1.40	1.80	0.055	0.071
L	0.30	0.60	0.012	0.024
L_1	0.08	0.25	0.003	0.010
α	0°	10°	0°	10°

Physical Specifications

Terminal Material	Solder-Plated Copper (Solder Material : 90/10 or 63/37 SnPb)
Lead Solderability	Meets EIA Specification RSI86-91, ANSI/J-STD-002 Category 3.
Packaging	2500 devices per reel

Reflow Condition (IR/Convection or VPR Reflow)

Reference JEDEC Standard J-STD-020A APRIL 1999

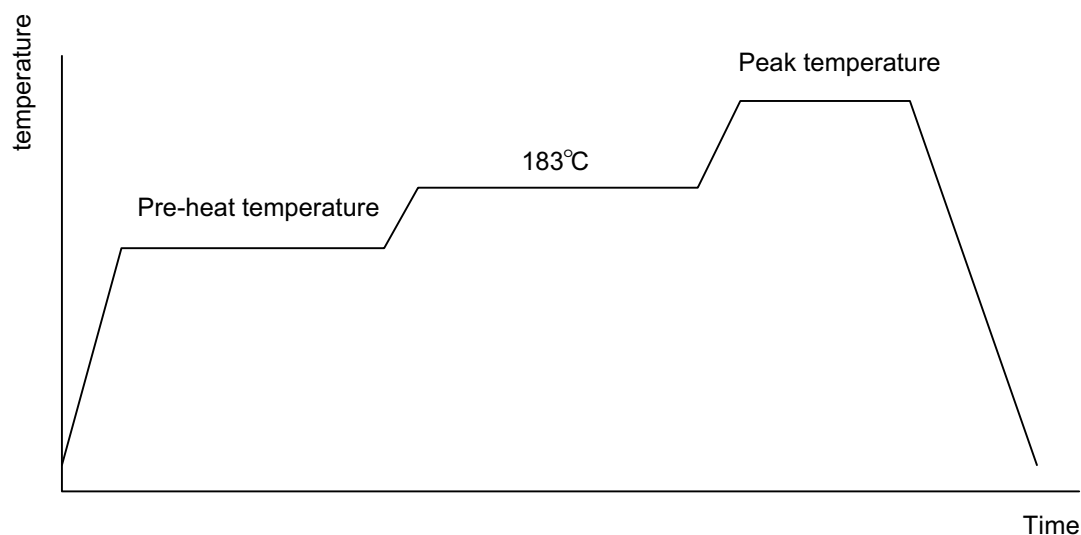

Classification Reflow Profiles

	Convection or IR/ Convection	VPR
Average ramp-up rate(183°C to Peak)	3°C/second max.	10 °C /second max.
Preheat temperature 125 ± 25°C)	120 seconds max	
Temperature maintained above 183°C	60 – 150 seconds	
Time within 5°C of actual peak temperature	10 –20 seconds	60 seconds
Peak temperature range	220 +5/-0°C or 235 +5/-0°C	215-219°C or 235 +5/-0°C
Ramp-down rate	6 °C /second max.	10 °C /second max.
Time 25°C to peak temperature	6 minutes max.	

Package Reflow Conditions

pkg. thickness ≥ 2.5mm and all bgas	pkg. thickness < 2.5mm and pkg. volume ≥ 350 mm ³	pkg. thickness < 2.5mm and pkg. volume < 350mm ³
Convection 220 +5/-0 °C		Convection 235 +5/-0 °C
VPR 215-219 °C		VPR 235 +5/-0 °C
IR/Convection 220 +5/-0 °C		IR/Convection 235 +5/-0 °C

Reliability test program

Test item	Method	Description
SOLDERABILITY	MIL-STD-883D-2003	245°C , 5 SEC
HOLT	MIL-STD-883D-1005.7	1000 Hrs Bias @ 125 °C
PCT	JESD-22-B, A102	168 Hrs, 100 % RH , 121°C
TST	MIL-STD-883D-1011.9	-65°C ~ 150°C, 200 Cycles
ESD	MIL-STD-883D-3015.7	VHBM > 2KV, VMM > 200V
Latch-Up	JESD 78	10ms , I _{tr} > 100mA

Carrier Tape & Reel Dimensions

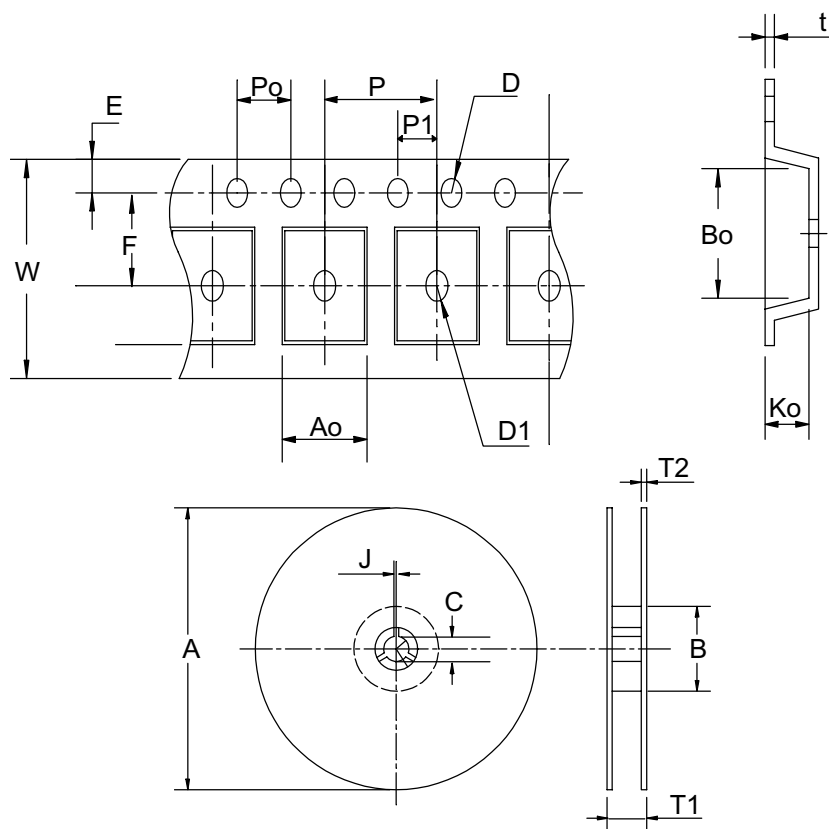

Application	A	B	C	J	T1	T2	W	P	E
SOT-23-5	178±1	72 ± 1.0	13.0 + 0.2	2.5 ± 0.15	8.4 ± 2	1.5± 0.3	8.0 ^{+0.3} _{-0.3}	4 ± 0.1	1.75± 0.1
	F	D	D1	Po	P1	Ao	Bo	Ko	t
	3.5 ± 0.05	1.5 + 0.1	1.5 + 0.1	4.0 ± 0.1	2.0 ± 0.1	3.15 ± 0.1	3.2± 0.1	1.4± 0.1	0.2±0.03

(mm)

Cover Tape Dimensions

Application	Carrier Width	Cover Tape Width	Devices Per Reel
SOT- 23/-5/-6	8	5.3	3000

(mm)

Customer Service

Anpec Electronics Corp.

Head Office :

5F, No. 2 Li-Hsin Road, SBIP,

Hsin-Chu, Taiwan, R.O.C.

Tel : 886-3-5642000

Fax : 886-3-5642050

Taipei Branch :

7F, No. 137, Lane 235, Pac Chiao Rd.,

Hsin Tien City, Taipei Hsien, Taiwan, R. O. C.

Tel : 886-2-89191368

Fax : 886-2-89191369