

# 32-bit Proprietary Microcontrollers

CMOS

## FR30 Family MB91150 Series

# MB91F155A/MB91155/MB91154

### DESCRIPTION

The MB91F155A/MB91155/MB91154 is a single-chip microcontroller using a RISC-CPU (FR 30 series) as its core. It contains peripheral I/O resources suitable for audio, MD and so on which are required to operate at low power consumption.

### FEATURES

#### 1. CPU

- 32-bit RISC (FR30) , load/store architecture, 5-stage pipeline
- General-purpose registers : 32 bits × 16
- 16-bit fixed-length instructions (basic instructions) , 1 instruction/ 1 cycle
- Memory-to-memory transfer, bit processing, barrel shift processing : Optimized for embedded applications
- Function entrance/exit instructions, and multiple load/store instructions of register contents, instruction systems supporting high level languages
- Register interlock functions, efficient assembly language description
- Branch instructions with delay slots : Reduced overhead time in branching executions
- Internal multiplier/supported at instruction level
  - Signed 32-bit multiplication : 5 cycles
  - Signed 16-bit multiplication : 3 cycles
- Interrupt (PC and PS saving) : 6 cycles, 16 priority levels

(Continued)

### PACKAGE

144-pin plastic LQFP

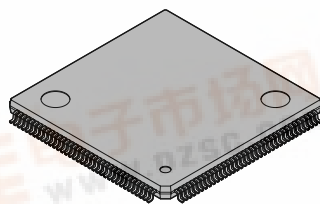

(FPT-144P-M08)

144-pin plastic LQFP

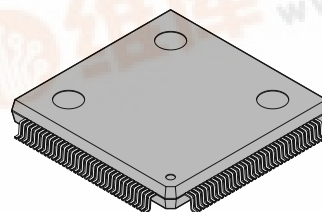

(FPT-144P-M01)

# MB91F155A/MB91155/MB91154

## 2. Bus Interface

- 16-bit address output, 8/16-bit data input and output
- Basic bus cycle : 2-clock cycle
- Support for interface for various types of memory
- Unused data/address pins can be configured as input/output ports
- Support for little endian mode

## 3. Internal ROM

MB91F155A

FLASH products : 510 Kbytes

MB91155

Mask product : 510 Kbytes

MB91154

Mask product : 384 Kbytes

## 4. Internal RAM

Mask, FLASH products : 2 Kbytes

## 5. Internal Data RAM

MB91F155, MB91155

FLASH, Mask products : 32 Kbytes

MB91154

FLASH, Mask product : 20 Kbytes

## 6. DMAC

DMAC in descriptor format for placing transfer parameters on to the main memory.  
Capable of transferring a maximum of eight internal and external factors combined.  
Three channels for external factors

## 7. Bit Search Module

Searches in one cycle for the position of the bit that changes from the MSB in one word to the initial I/O.

## 8. Timers

- 16-bit OCU × 8 channels, ICU × 4 channels, Free-run timer × 1 channel
- 8/16-bit up/down timer/counter (8-bit × 2 channels or 16-bit × 1 channel)
- 16-bit PPG timer × 6 channels. The output pulse cycle and duty can be varied as desired
- 16-bit reload timer × 4 channels

## 9. D/A Converter

- 8-bit × 3 channels

## 10. A/D Converter (Sequential Comparison Type)

- 10-bit × 8 channels
- Sequential conversion method (conversion time : 5.0 μs@33 MHz)
- Single conversion or scan conversion can be selected, and one-shot or continuous or stop conversion mode can be set respectively.
- Conversion starting function by hardware/software.

(Continued)

# MB91F155A/MB91155/MB91154

(Continued)

## 11. Serial I/O

- UART × 4 channels. Any of them is capable of serial transfer in sync with clock attached with the LSB/MSB switching function.
- Serial data output and serial clock output are selectable by push-pull/open drain software.
- A 16-bit timer (U-timer) is contained as a dedicated baud rate generator allowing any baud rate to be generated.

## 12. I<sup>2</sup>C Bus Interface

- One channel master/slave send and receive
- Arbitration and clock synchronization functions  
(The product is licensed with the Philips I<sup>2</sup>C patent to support those customers who intend to use this product in an I<sup>2</sup>C system in compliance with the standard I<sup>2</sup>C specification stipulated by Philips.)

## 13. Clock Switching Function

- Gear function : Operating clock ratios to the basic clock can be set independently for the CPU and peripherals from four types, 1 : 1, 1 : 2, 1 : 4 or 1 : 8.

## 14. Clock Function (Calendar Macro)

- Internal 32 kHz clock function
- It is possible to perform the clock function (oscillation frequency: 32 kHz) even in a stop mode. (The oscillation does not suspend during a stop mode.)

## 15. Interrupt Controller

External interrupt input (16 channels in total) :

- Allows the rising edge/falling edge/H level/L level to be set.

Internal interrupt factors :

- Interrupt by resources and delay interrupt

## 16. Others

- Reset cause : Power on reset/watchdog timer/software reset/external reset
- Low power consumption mode : Sleep/stop
- Package : 144-pin LQFP
- CMOS technology (0.35 μm)
- Power supply voltage : 3.15 V to 3.6 V
- MB91F155 is to be MB91F155A.

# MB91F155A/MB91155/MB91154

## PIN ASSIGNMENT

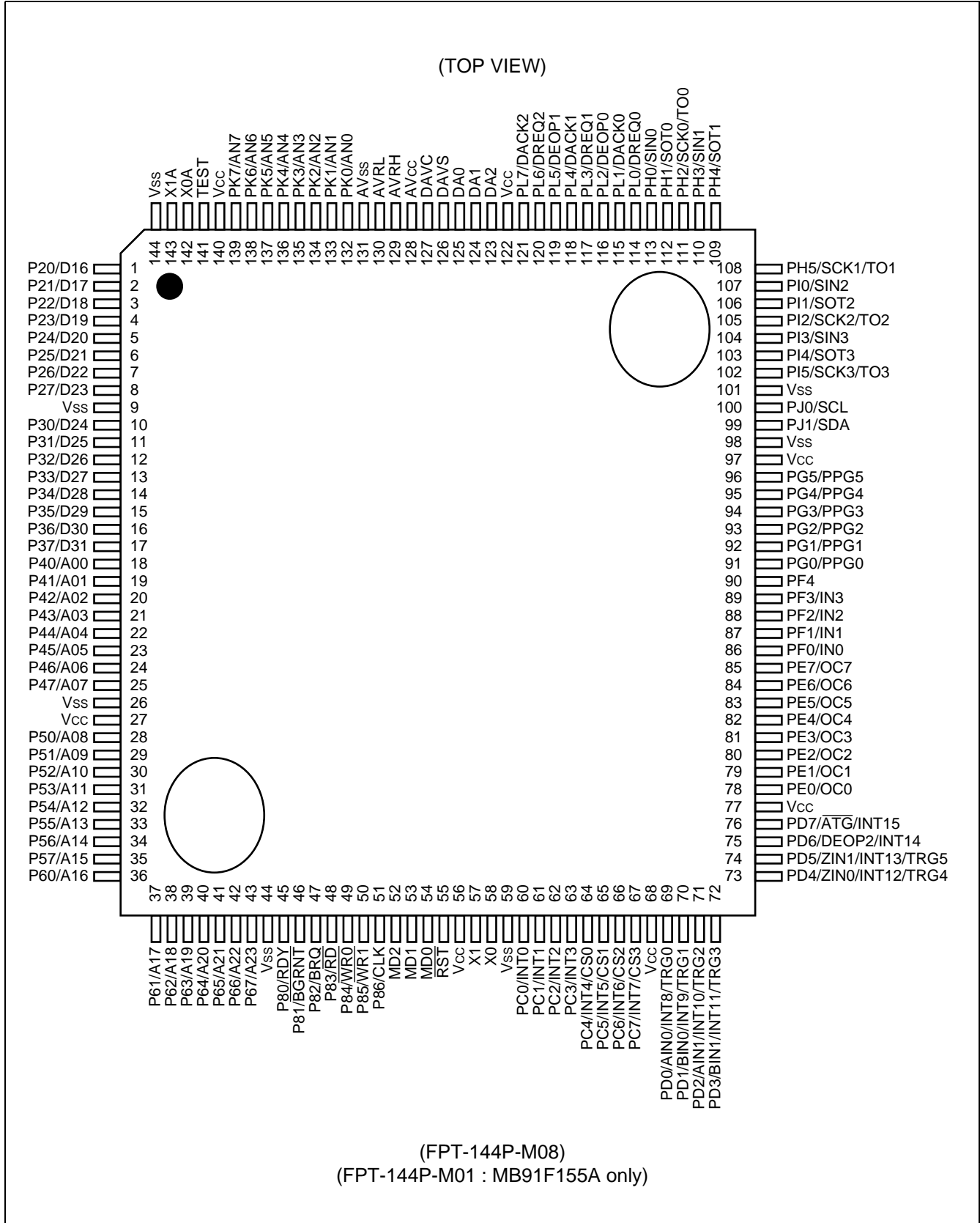

# MB91F155A/MB91155/MB91154

## ■ PIN DESCRIPTION

Pin No.	Pin name	Circuit type	Function
1 2 3 4 5 6 7 8	D16/P20 D17/P21 D18/P22 D19/P23 D20/P24 D21/P25 D22/P26 D23/P27	C	Bit 16 to bit 23 of external data bus These pins are enabled only in 16-bit external bus mode. These pins are available as ports in single-chip and 8-bit external bus modes.
10 11 12 13 14 15 16 17	D24/P30 D25/P31 D26/P32 D27/P33 D28/P34 D29/P35 D30/P36 D31/P37	C	Bit 24 to bit 31 of external data bus These pins are available as ports in single-chip mode.
18 19 20 21 22 23 24 25 28 29 30 31 32 33 34 35	A00/P40 A01/P41 A02/P42 A03/P43 A04/P44 A05/P45 A06/P46 A07/P47 A08/P50 A09/P51 A10/P52 A11/P53 A12/P54 A13/P55 A14/P56 A15/P57	F	Bit 0 to bit 15 of external address bus These pins are enabled in external bus mode. These pins are available as ports in single-chip mode.
36 37 38 39 40 41 42 43	A16/P60 A17/P61 A18/P62 A19/P63 A20/P64 A21/P65 A22/P66 A23/P67	O	Bit 16 to bit 23 of external address bus These pins are available as ports when the address bus is not in use.
45	RDY/P80	C	External RDY input This function is enabled when external RDY input is allowed. Input "0" when the bus cycle being executed does not end. This pin is available as a port when external RDY input is not in use.

(Continued)

# MB91F155A/MB91155/MB91154

Pin No.	Pin name	Circuit type	Function
46	$\overline{\text{BGRNT}}/\text{P81}$	F	External bus release acceptance output This function is enabled when external bus release acceptance output is allowed. Output "L" upon releasing of the external bus. This pin is available as a port when external bus release acceptance output is not allowed.
47	BRQ/P82	C	External bus release request input This function is enabled when external bus release request input is allowed. Input "1" when the release of the external bus is desired. This pin is available as a port when external bus release request input is not in use.
48	$\overline{\text{RD}}/\text{P83}$	F	External bus read strobe output This function is enabled when external bus read strobe output is allowed. This pin is available as a port when external bus read strobe output is not allowed.
49	$\overline{\text{WR0}}/\text{P84}$	F	External bus write strobe output This function is enabled in external bus mode. This pin is available as a port in single chip mode.
50	$\overline{\text{WR1}}/\text{P85}$	F	External bus write strobe output This function is enabled in external bus mode when the bus width is 16 bits. This pin is available as a port in single chip mode or when the external bus width is 8 bits.
51	CLK/P86	F	System clock output The pin outputs the same clock as the external bus operating frequency. The pin is available as a port when it is not used to output the clock.
52 53 54	MD2 MD1 MD0	G	Mode pins To use these pins, connect them directly to either $V_{CC}$ or $V_{SS}$ . Use these pins to set the basic MCU operating mode.
55	$\overline{\text{RST}}$	B	External reset input
57 58	X1 X0	A	High-speed clock oscillation pins (16.5 MHz)
60 61 62 63	INT0/PC0 INT1/PC1 INT2/PC2 INT3/PC3	H	External interrupt request input 0-3 Since this input is used more or less continuously when the corresponding external interrupt is allowed, output by the port needs to be stopped except when it is performed deliberately. Since this port is allowed to input also in standby mode, it can be used to reset the standby state. These pins are available as ports when external interrupt request input is not in use.

(Continued)

# MB91F155A/MB91155/MB91154

Pin No.	Pin name	Circuit type	Function
64 65 66 67	INT4/PC4/CS0 INT5/PC5/CS1 INT6/PC6/CS2 INT7/PC7/CS3	H	<p>These pins also serve as the chip select output and external interrupt request input 4-7.</p> <p>When the chip select output is not allowed, these pins are available as external interrupt requests or ports.</p> <p>Since this input is used more or less continuously when the corresponding external interrupt is allowed, output by the port needs to be stopped except when it is performed deliberately.</p> <p>Since this port is also allowed to input in standby mode, the port can be used to reset the standby state.</p> <p>These pins are available as ports when external interrupt request input and chip select output are not in use.</p>
69 70 71 72 73 74	PD0/AIN0/INT8/TRG0 PD1/BIN0/INT9/TRG1 PD2/AIN1/INT10/TRG2 PD3/BIN1/INT11/TRG3 PD4/ZIN0/INT12/TRG4 PD5/ZIN1/INT13/TRG5	H	<p>External interrupt request input 8-13</p> <p>Since this input is used more or less continuously when the corresponding external interrupt is allowed, output by the port needs to be stopped except when it is performed deliberately.</p> <p>[AIN, BIN] Up/down timer input.</p> <p>[TRG] PPG external trigger input.</p> <p>Since this input is used more or less continuously while input is allowed, output by the port needs to be stopped except when it is performed deliberately.</p> <p>These pins are available as ports when the external interrupt request input, up timer counter input, and PPG external trigger input are not in use.</p>
75	PD6/DEOP2/INT14	H	<p>External interrupt request input 14</p> <p>Since this input is used more or less continuously when the corresponding external interrupt is allowed, output by the port needs to be stopped except when it is performed deliberately.</p> <p>[DEOP2] DMA external transfer end output.</p> <p>This function is enabled when DMAC external transfer end output is allowed.</p> <p>This pin is available as a port when it is not in use as the external interrupt request input or DMA external transfer end output.</p>
76	PD7/ $\overline{\text{ATG}}$ /INT15	H	<p>External interrupt request input 15</p> <p>Since this input is used more or less continuously when the corresponding external interrupt is allowed, output by the port needs to be stopped except when it is performed deliberately.</p> <p>[<math>\overline{\text{ATG}}</math>] A/D converter external trigger input.</p> <p>Since this input is used more or less continuously when selected as an A/D activation factor, output by the port needs to be stopped except when it is performed deliberately.</p> <p>This pin is available as a port when it is not in use as the external interrupt request input or A/D converter external trigger input.</p>

(Continued)

# MB91F155A/MB91155/MB91154

Pin No.	Pin name	Circuit type	Function
78 79 80 81 82 83 84 85	PE0/OC0 PE1/OC1 PE2/OC2 PE3/OC3 PE4/OC4 PE5/OC5 PE6/OC6 PE7/OC7	F	Output compare output These pins are available as ports when output compare output is not allowed.
86 87 88 89	PF0/IN0 PF1/IN1 PF2/IN2 PF3/IN3	F	Input capture input This function is enabled when the input capture operation is input. These pins are available as ports when input capture input is not in use.
90	PF4	F	General purpose I/O port
91 92 93 94 95 96	PG0/PPG0 PG1/PPG1 PG2/PPG2 PG3/PPG3 PG4/PPG4 PG5/PPG5	F	PPG timer output This function is enabled when PPG timer output is allowed. These pins are available as ports when PPG timer output is not allowed.
99	PJ1/SDA	Q	I <sup>2</sup> C interface I/O pin This function is enabled when the I <sup>2</sup> C interface is allowed to operate. While the I <sup>2</sup> C interface is in operation, keep the port output set to Hi-Z. This pin is available as a port when the I <sup>2</sup> C interface is not in use.
100	PJ0/SCL	Q	I <sup>2</sup> C interface I/O pin This function is enabled when the I <sup>2</sup> C interface is allowed to operate. While the I <sup>2</sup> C interface is in operation, keep the port output set to Hi-Z. This pin is available as a port when the I <sup>2</sup> C interface is not in use.
102	PI5/SCK3/TO3	P	UART3 clock I/O, Reload timer 3 output When UART3 clock output is not allowed, reload timer 3 can be output by allowing it. This pin is available as a port when neither UART3 clock output nor reload timer output is allowed.
103	PI4/SOT3	P	UART3 data output This function is enabled when UART3 data output is allowed. This pin is available as a port when UART3 clock output is not allowed.
104	PI3/SIN3	P	UART3 data input Since this input is used more or less continuously while UART3 is engaged in input operations, output by the port needs to be stopped except when it is performed deliberately. This pin is available as a port when UART3 output data input is not in use.

(Continued)



# MB91F155A/MB91155/MB91154

Pin No.	Pin name	Circuit type	Function
105	PI2/SCK2/TO2	P	UART2 clock I/O, Reload timer 2 output When UART2 clock output is not allowed, reload timer 2 can be output by allowing it. This pin is available as a port when neither UART2 clock output nor reload timer output is allowed.
106	PI1/SOT2	P	UART2 data output This function is enabled when UART2 data output is allowed. This pin is available as a port when UART2 clock output is not allowed.
107	PI0/SIN2	P	UART2 data input Since this input is used more or less continuously while UART2 is engaged in input operations, output by the port needs to be stopped except when it is performed deliberately. This pin is available as a port when UART2 data input is not in use.
108	PH5/SCK1/TO1	P	UART1 clock I/O, Reload timer 1 output When UART1 clock output is not allowed, reload timer 1 can be output by allowing it. This pin is available as a port when neither UART1 clock output nor reload timer output is allowed.
109	PH4/SOT1	P	UART1 data output This function is enabled when UART1 data output is allowed. This pin is available as a port when UART1 clock output is not allowed.
110	PH3/SIN1	P	UART1 data input Since this input is used more or less continuously while UART1 is engaged in input operations, output by the port needs to be stopped except when it is performed deliberately. This pin is available as a port when UART1 data input is not in use.
111	PH2/SCK0/TO0	P	UART0 clock I/O, Reload timer 0 output When UART0 clock output is not allowed, reload timer 0 can be output by allowing it. This pin is available as a port when neither UART0 clock output nor reload timer output is allowed.
112	PH1/SOT0	P	UART0 data output This function is enabled when UART0 data output is allowed. This pin is available as a port when UART0 clock output is not allowed.
113	PH0/SIN0	P	UART0 data input Since this input is used more or less continuously while UART0 is engaged in input operations, output by the port needs to be stopped except when it is performed deliberately. This pin is available as a port when UART0 data input is not in use.
114	DREQ0/PL0	F	DMA external transfer request input Since this input is used more or less continuously when selected as a DMAC transfer factor, output by the port needs to be stopped except when it is performed deliberately. This pin is available as a port when DMA external transfer request input is not in use.

(Continued)

# MB91F155A/MB91155/MB91154

Pin No.	Pin name	Circuit type	Function
115	DACK0/PL1	F	DMA external transfer request acceptance output This function is enabled when the DMAC external transfer request acceptance is allowed to be output. This pin is available as a port when the DMAC transfer request acceptance is not allowed to be output.
116	DEOP0/PL2	F	DMA external transfer end output This function is enabled when the end of DMAC external transfer is allowed to be output.
117	DREQ1/PL3	F	DMA external transfer request input Since this input is used more or less continuously when selected as a DMAC transfer factor, output by the port needs to be stopped except when it is performed deliberately. This pin is available as a port when DMA external transfer request input is not in use.
118	DACK1/PL4	F	DMA external transfer request acceptance output This function is enabled when the DMAC external transfer request acceptance is allowed to be output. This pin is available as a port when DMAC transfer request acceptance output is not allowed.
119	DEOP1/PL5	F	DMA external transfer end output This function is enabled when the end of DMAC external transfer is allowed to be output.
120	DREQ2/PL6	F	DMA external transfer request input Since this input is used more or less continuously when selected as a DMAC transfer factor, output by the port needs to be stopped except when it is performed deliberately. This pin is available as a port when DMA external transfer request input is not in use.
121	DACK2/PL7	F	DMA external transfer request acceptance output This function is enabled when the DMAC external transfer request acceptance is allowed to be output. This pin is available as a port when DMAC transfer request acceptance output is not allowed.
123 124 125	DA2 DA1 DA0	—	D/A converter output This function is enabled when D/A converter output is allowed.
126	DAVS	—	Power supply pin for the D/A converter
127	DAVC	—	Power supply pin for the D/A converter
128	AV <sub>cc</sub>	—	V <sub>cc</sub> power supply for the A/D converter
129	AVRH	—	A/D converter reference voltage (high potential side) Be sure to turn on/off this pin with potential higher than AVRH applied to V <sub>cc</sub> .
130	AVRL	—	A/D converter reference voltage (low potential side)
131	AV <sub>ss</sub>	—	V <sub>ss</sub> power supply for the A/D converter

(Continued)

# MB91F155A/MB91155/MB91154

(Continued)

Pin No.	Pin name	Circuit type	Function
132 133 134 135 136 137 138 139	AN0/PK0 AN1/PK1 AN2/PK2 AN3/PK3 AN4/PK4 AN5/PK5 AN6/PK6 AN7/PK7	N	A/D converter analog input These pins are enabled when the AIC register is designated for analog input. These pins are available as ports when A/D converter analog input is not in use.
141	TEST	G	The TEST pin must be connected to the power supply ( $V_{CC}$ )
142 143	X0A X1A	K	Low-speed clock (32 kHz) oscillation pin
27, 56, 68, 77, 97, 122, 140	$V_{CC}$	—	Power supply pin ( $V_{CC}$ ) for digital circuit Always power supply pin ( $V_{CC}$ ) must be connected to the power supply
9, 26, 44, 59, 98, 101, 144	$V_{SS}$	—	Earth level ( $V_{SS}$ ) for digital circuit Always power supply pin ( $V_{SS}$ ) must be connected to the power supply

Note : On the majority of pins listed above, the I/O port and the resource I/O are multiplexed, such as XXXX/Pxx.  
When the port and the resource output compete against each other on these pins, priority is given to the resource.

# MB91F155A/MB91155/MB91154

## ■ I/O CIRCUIT TYPE

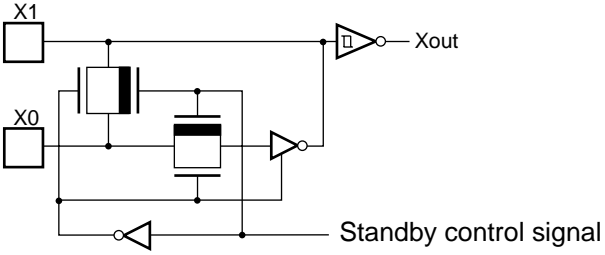
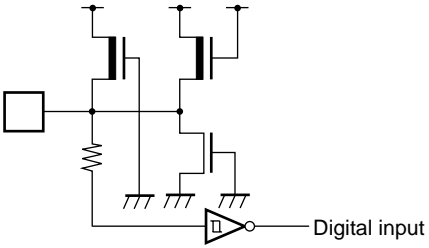
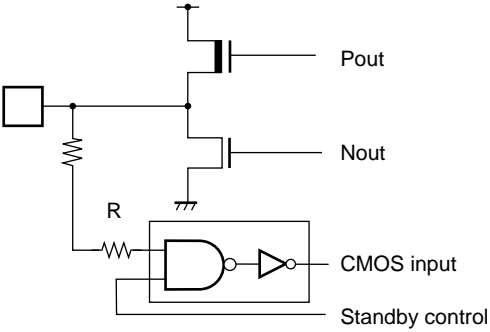
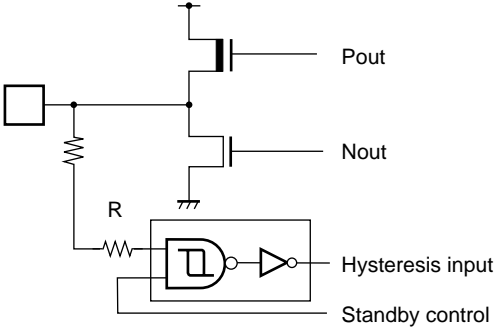
Type	Circuit	Remarks
A		<ul style="list-style-type: none"> <li>High-speed oscillation circuit (16.5 MHz)</li> <li>Oscillation feedback resistor = approx. 1 MΩ</li> </ul>
B		<ul style="list-style-type: none"> <li>CMOS hysteresis input pin</li> <li>CMOS hysteresis input (standby control not attached)</li> <li>Pullup resistor</li> </ul>
C		<ul style="list-style-type: none"> <li>CMOS level I/O pin</li> <li>CMOS level output</li> <li>CMOS level input (attached with standby control)</li> <li><math>I_{OL} = 4 \text{ mA}</math></li> </ul>
F		<ul style="list-style-type: none"> <li>CMOS hysteresis I/O pin</li> <li>CMOS level output</li> <li>CMOS hysteresis input (attached with standby control)</li> <li><math>I_{OL} = 4 \text{ mA}</math></li> </ul>

(Continued)

# MB91F155A/MB91155/MB91154

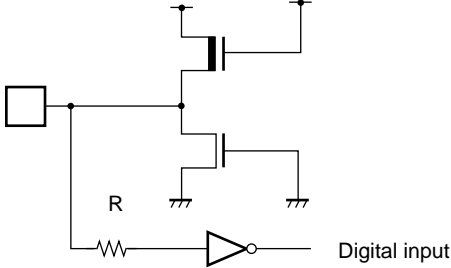
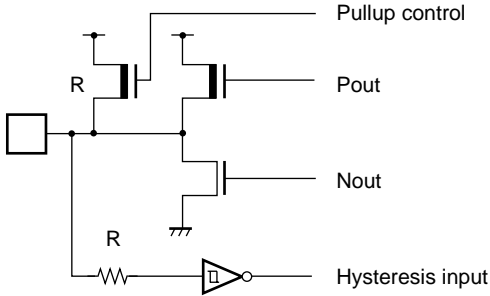
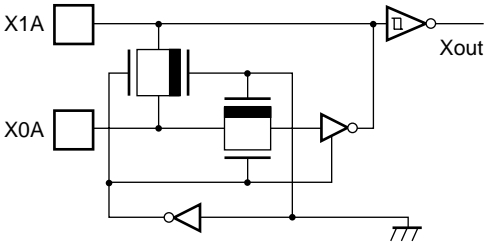
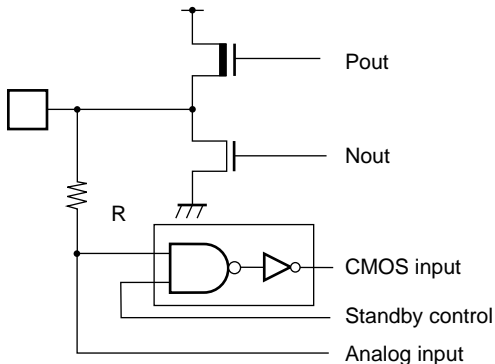
Type	Circuit	Remarks
G	 <p style="text-align: right;">Digital input</p>	<ul style="list-style-type: none"> <li>• CMOS level input pin CMOS level input (standby control not attached)</li> </ul>
H	 <p style="text-align: right;">Pullup control Pout Nout Hysteresis input</p>	<ul style="list-style-type: none"> <li>• CMOS hysteresis I/O pin with pull-up control CMOS level output CMOS level input (standby control not attached) Pullup resistance = approx. 50 kΩ (Typ.)  I<sub>OL</sub> = 4 mA</li> </ul>
K	 <p style="text-align: right;">Xout</p>	<ul style="list-style-type: none"> <li>• Clock oscillation circuit (32 kHz)</li> </ul>
N	 <p style="text-align: right;">Pout Nout CMOS input Standby control Analog input</p>	<ul style="list-style-type: none"> <li>• Analog/CMOS level I/O pin. CMOS level output CMOS level input (attached with standby control) Analog input (Analog input is enabled when AIC's corresponding bit is set to "1.")  I<sub>OL</sub> = 4 mA</li> </ul>

(Continued)

# MB91F155A/MB91155/MB91154

(Continued)

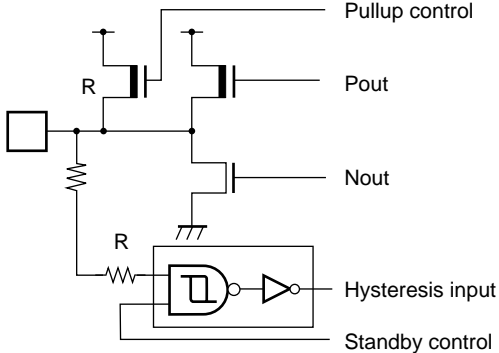
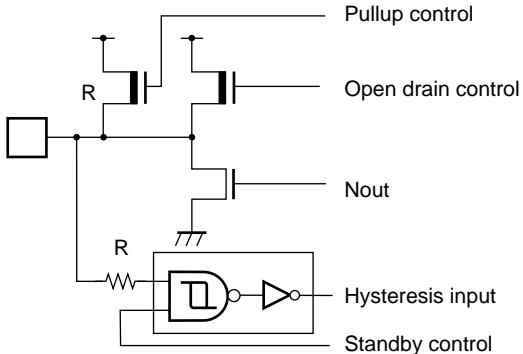
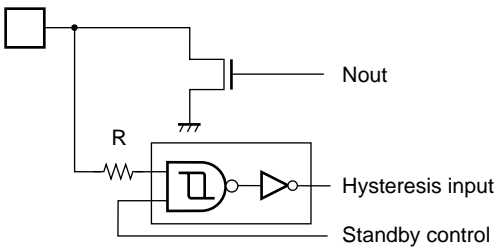
Type	Circuit	Remarks
O	 <p>Pullup control</p> <p>Pout</p> <p>Nout</p> <p>Hysteresis input</p> <p>Standby control</p>	<ul style="list-style-type: none"> <li>• CMOS hysteresis I/O pin with pullup control</li> <li>• CMOS level output</li> <li>• CMOS hysteresis input (attached with standby control)</li> <li>• Pullup resistance = approx. 50 kΩ (Typ.)</li> </ul> <p><math>I_{OL} = 4 \text{ mA}</math></p>
P	 <p>Pullup control</p> <p>Open drain control</p> <p>Nout</p> <p>Hysteresis input</p> <p>Standby control</p>	<ul style="list-style-type: none"> <li>• CMOS hysteresis I/O pin with pullup control.</li> <li>• CMOS level output (attached with open drain control)</li> <li>• CMOS hysteresis input (attached with standby control)</li> <li>• Pullup resistance = approx. 50 kΩ (Typ.)</li> </ul> <p><math>I_{OL} = 4 \text{ mA}</math></p>
Q	 <p>Nout</p> <p>Hysteresis input</p> <p>Standby control</p>	<ul style="list-style-type: none"> <li>• Open drain I/O pin</li> <li>• 5 V tolerance of voltage</li> <li>• CMOS hysteresis input (attached with standby control)</li> </ul> <p><math>I_{OL} = 15 \text{ mA}</math></p>

# MB91F155A/MB91155/MB91154

## ■ HANDLING DEVICES

### 1. Preventing Latchup

In CMOS ICs, applying voltage higher than  $V_{CC}$  or lower than  $V_{SS}$  to input/output pin or applying voltage over rating across  $V_{CC}$  and  $V_{SS}$  may cause latchup.

This phenomenon rapidly increases the power supply current, which may result in thermal breakdown of the device. Make sure to prevent the voltage from exceeding the maximum rating.

### 2. Treatment of Pins

#### • Treatment of unused pins

Unused pins left open may cause malfunctions. Make sure to connect them to pull-up or pull-down resistors.

#### • Treatment of open pins

Be sure to use open pins in open state.

#### • Treatment of output pins

Shortcircuiting an output pin with the power supply or with another output pin or connecting a large-capacity load may causes a flow of large current. If this conditions continues for a lengthy period of time, the device deteriorates. Take great care not to exceed the absolute maximum ratings.

#### • Mode pins (MD0-MD2)

These pins should be used directly connected to either  $V_{CC}$  or  $V_{SS}$ . In order to prevent noise from causing accidental entry into test mode, keep the pattern length as short as possible between each mode pin and  $V_{CC}$  or  $V_{SS}$  on the board and connect them with low impedance.

#### • Power supply pins

When there are several  $V_{CC}$  and  $V_{SS}$  pins, each of them is equipotentially connected to its counterpart inside of the device, minimizing the risk of malfunctions such as latch up. To further reduce the risk of malfunctions, to prevent EMI radiation, to prevent strobe signal malfunction resulting from creeping-up of ground level and to observe the total output current standard, connect all  $V_{CC}$  and  $V_{SS}$  pins to the power supply or GND.

It is preferred to connect  $V_{CC}$  and  $V_{SS}$  of MB91F155/MB91154 to power supply with minimal impedance possible.

It is also recommended to connect a ceramic capacitor as a bypass capacitor of about 0.1  $\mu\text{F}$  between  $V_{CC}$  and  $V_{SS}$  at a position as close as possible to MB91F155/MB91154.

#### • Crystal oscillator circuit

Noises around X0, X1, X0A, and X1A pins may cause malfunctions of MB91F155/MB91154. In designing the PC board, layout X0, X1 (X0A, X1A) and crystal oscillator (or ceramic oscillator) and bypass capacitor for grounding as close as possible.

It is strongly recommended to design PC board so that X0, X1, X0A, and X1A pins are surrounded by grounding area for stable operation.

The MB91F155A, MB91155 and MB91154 devices do not contain a feedback resistor. To use the clock function, you need to connect an external resistor.

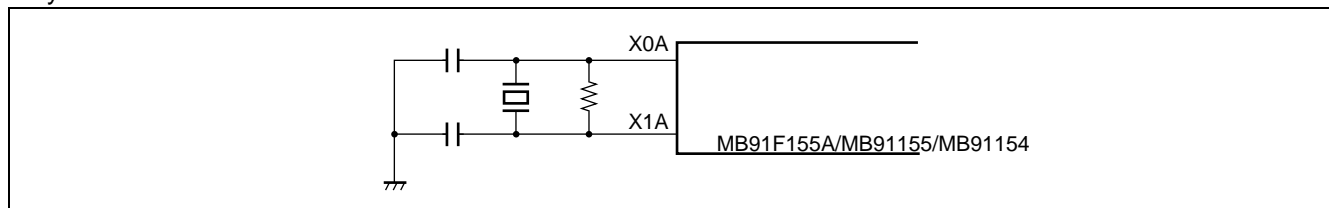

### 3. Precautions

#### • External Reset Input

It takes at least 5 machine cycle to input "L" level to the  $\overline{\text{RST}}$  pin and to ensure inner reset operation properly.

#### • External Clocks

When using an external clock, normally, a clock of which the phase is opposite to that of X0 must be supplied to the X0 and X1 pins simultaneously. However, when using the clock along with STOP (oscillation stopped)

# MB91F155A/MB91155/MB91154

mode, the X1 pin stops when “H” is input in STOP mode. To prevent one output from competing against another, an external resistor of about 1 k $\Omega$  should be provided.

The following figure shows an example usage of an external clock.

Figure 2.1 An example usage of an external clock

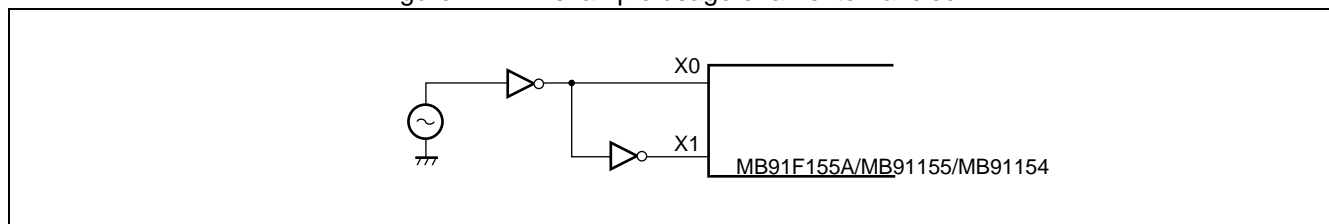

## 4. Care During Powering Up

### • When powering up

When turning on the power supply, never fail to start from setting the  $\overline{\text{RST}}$  pin to “L” level. And after the power supply voltage goes to  $V_{\text{CC}}$  level, at least after ensuring the time for 5 machine cycle, then set to “H” level.

### • Source oscillation input

At turning on the power supply, never fail to input the clock before cancellation of the oscillation stabilizing waiting.

### • Power on resetting

When powering up or when turning the power back on after the supply voltage drops below the operation assurance range, be sure to reset the power.

### • Power on sequence

Turn on the power in the order of  $V_{\text{CC}}$ ,  $AV_{\text{CC}}$  and  $AV_{\text{RH}}$ . The power should be disconnected in inverse order.

### • Even when an AD converter is not in use, connect $AV_{\text{CC}}$ to the $V_{\text{CC}}$ level and $AV_{\text{SS}}$ to the $V_{\text{SS}}$ level.

### • Even when a DA converter is not in use, connect $DA_{\text{VC}}$ to the $V_{\text{CC}}$ level and $DA_{\text{VS}}$ to the $V_{\text{SS}}$ level.

## 5. When the Clock Function (Calendar Macro) Is Not in Use

Not using the clock function, the clock oscillation pin must be configured as shown below.

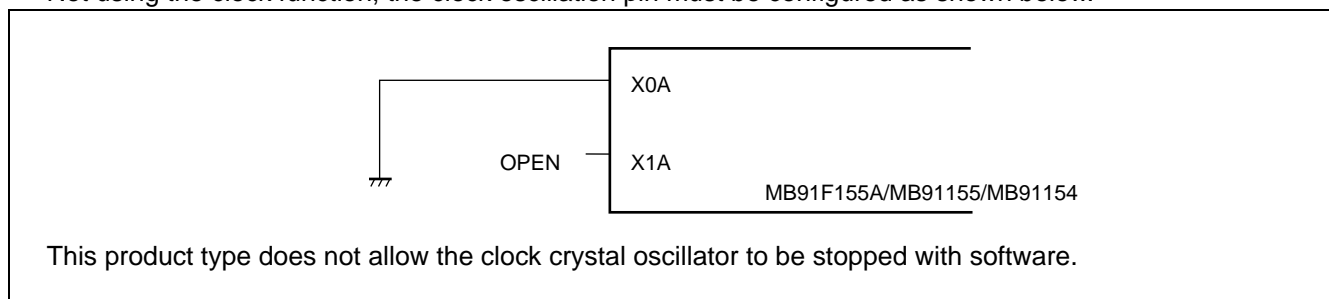

This product type does not allow the clock crystal oscillator to be stopped with software.



# MB91F155A/MB91155/MB91154

## ■ BLOCK DIAGRAM

• MB91F155A, MB91155

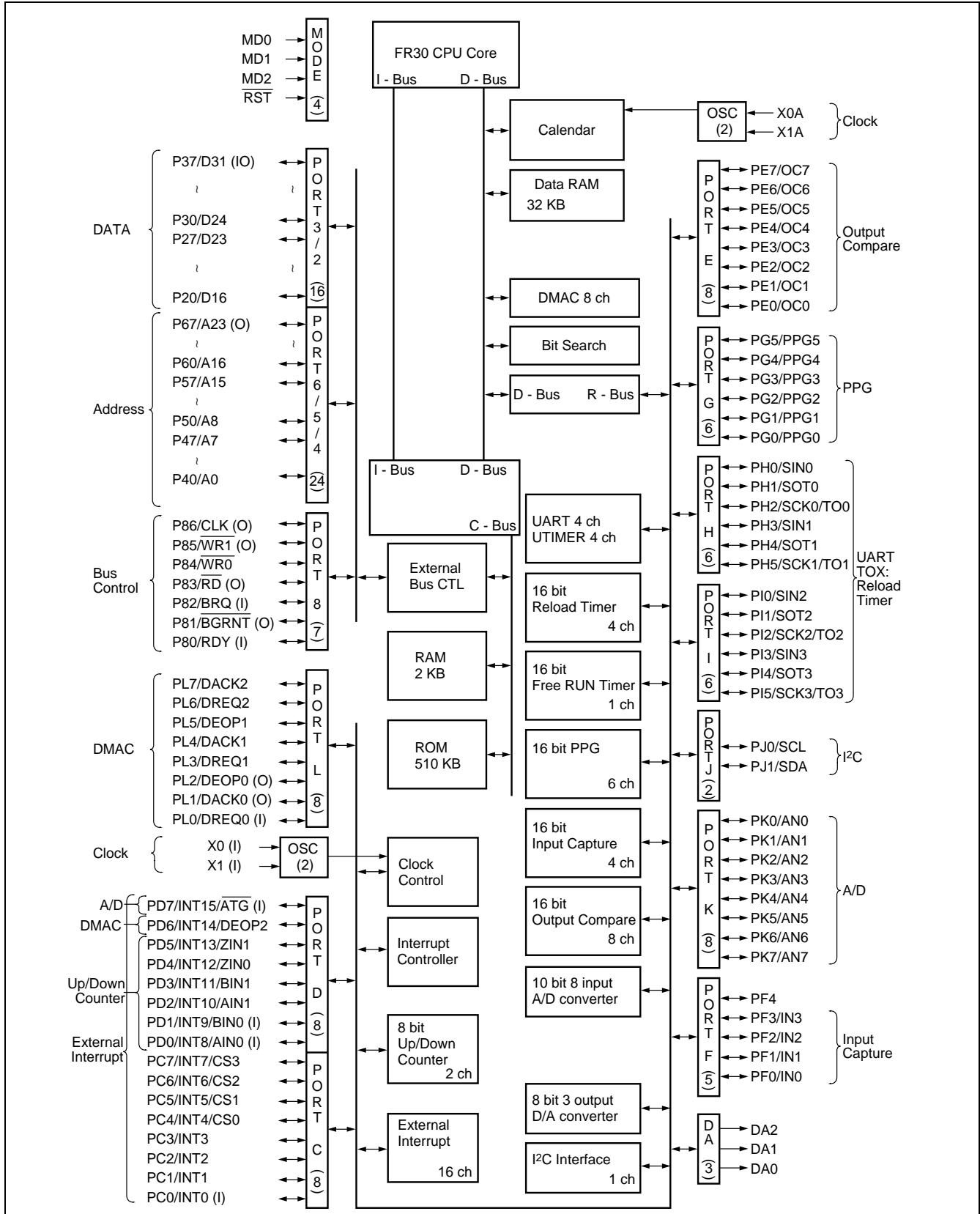

# MB91F155A/MB91155/MB91154

• MB91154

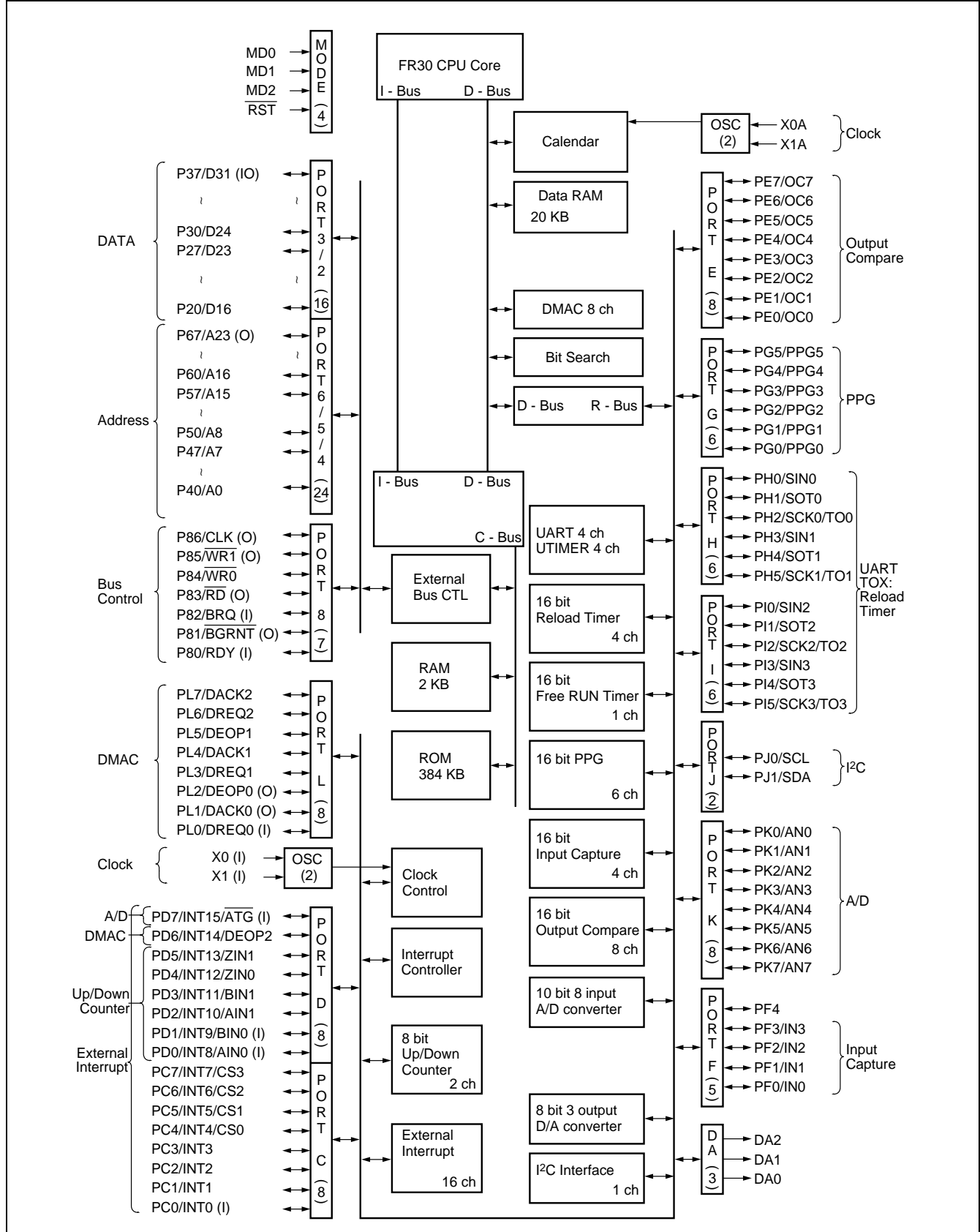

# MB91F155A/MB91155/MB91154

## ■ CPU CORE

### 1. Memory Space

The FR family has a logical address space of 4 Gbytes ( $2^{32}$  bytes) and the CPU linearly accesses the memory space.

#### • Direct addressing area

The following area in the address space is used for I/O.

This area is called direct addressing area and an operand address can be specified directly in an instruction.

The direct addressing area varies with the data size to be accessed as follows :

- byte data access : 0-0FF<sub>H</sub>
- half word data access : 0-1FF<sub>H</sub>
- word data access : 0-3FF<sub>H</sub>

### 2. Memory Map

#### • MB91F155, MB91155 Memory Space

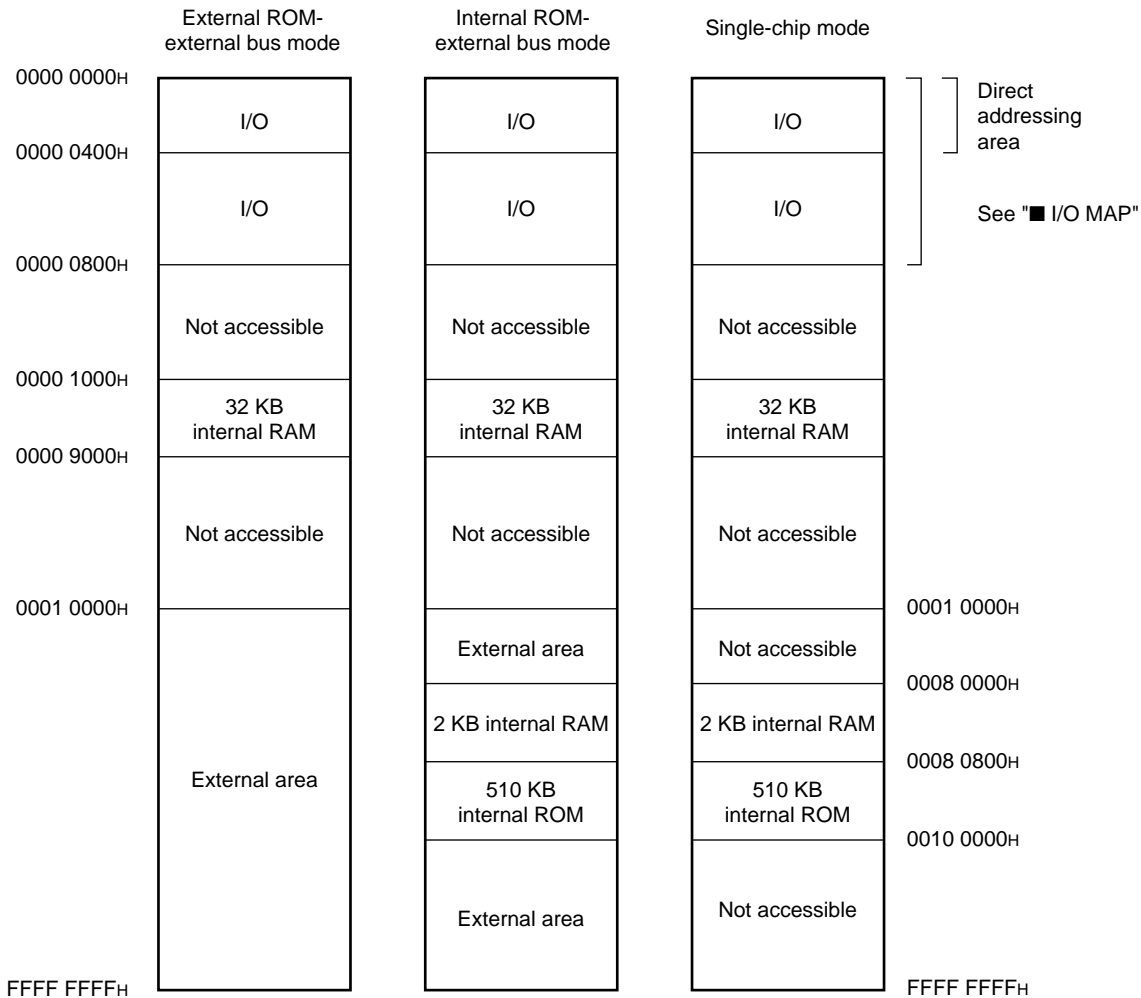

Note : External areas are not accessible in single-chip mode.

# MB91F155A/MB91155/MB91154

## • MB91154 Memory Space

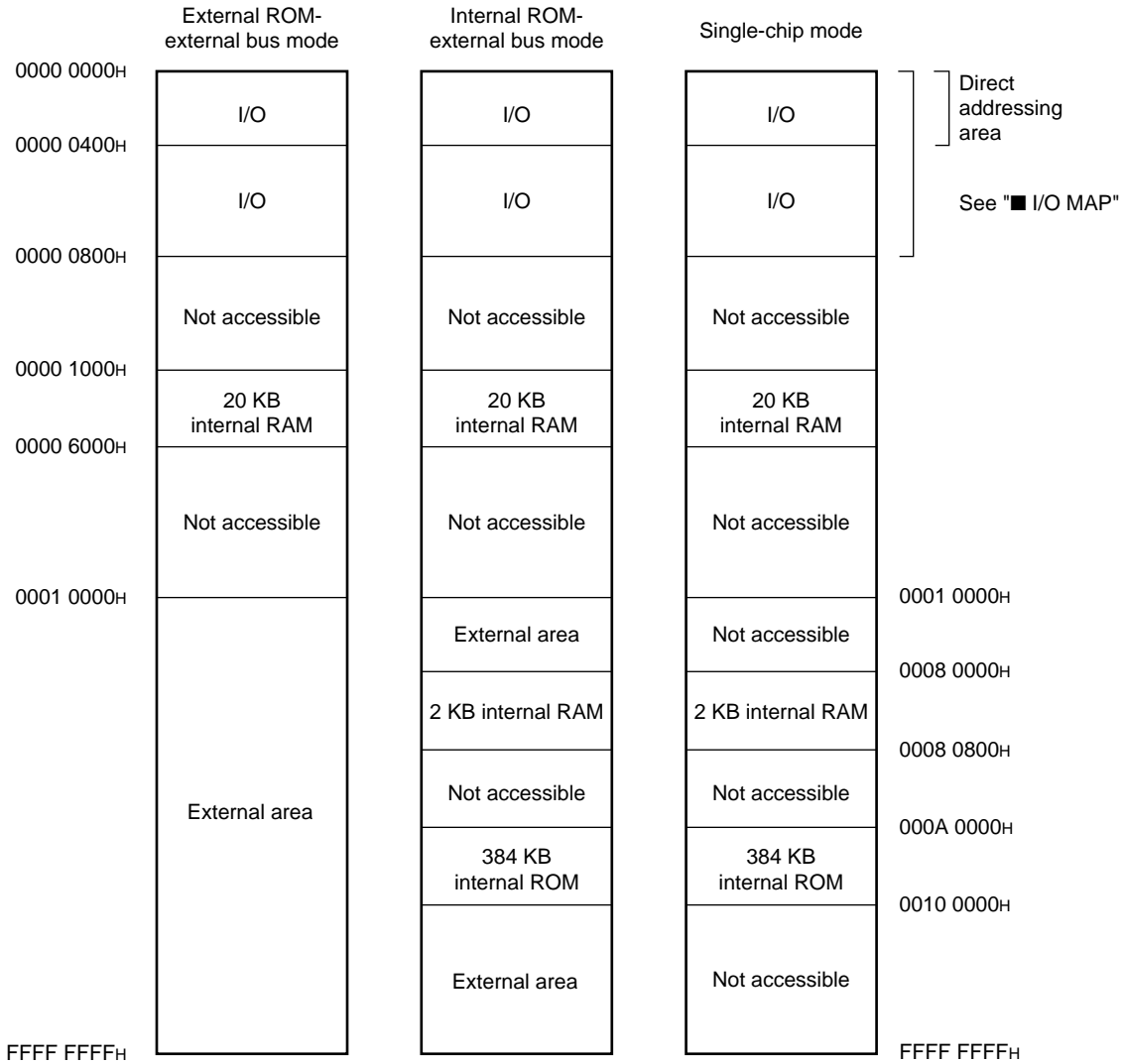

Note : External areas are not accessible in single-chip mode.

# MB91F155A/MB91155/MB91154

## 3. Registers

The family of FR microcontrollers has two types of registers : the registers residing in the CPU which are dedicated to applications and the general-purpose registers residing in the memory.

### • Dedicated registers :

- Program counter (PC) : A 32-bit register to indicate the location where an instructions is stored.
- Program status (PS) : A 32-bit register to store a register pointer or a condition code.
- Tablebase register (TBR) : Holds the vector table lead address used when EIT (exceptions/interrupt/ trap) is processed.
- Return pointer (RP) : Holds the address to return from a subroutine to.
- System stack pointer (SSP) : Points to the system stack space.
- User stack pointer (USP) : Points to the user stack space.
- Multiplication and division result register (MDH/MDL) : A 32-bit multiplication and division register.

Register Name	Description	Initial value
PC	Program counter	XXXX XXXXH (Undefined)
PS	Program status	
TBR	Tablebase register	000F FC00H
RP	Return pointer	XXXX XXXXH (Undefined)
SSP	System stack pointer	0000 0000H
USP	User stack pointer	XXXX XXXXH (Undefined)
MDH	Multiplication and division register	XXXX XXXXH (Undefined)
MDL		XXXX XXXXH (Undefined)

### • Program status (PS)

The PS register holds program status and is further divided into three registers which are a Condition Code Register (CCR) , a System condition Code Register (SCR) , and an Interrupt Level Mask register (ILM) .

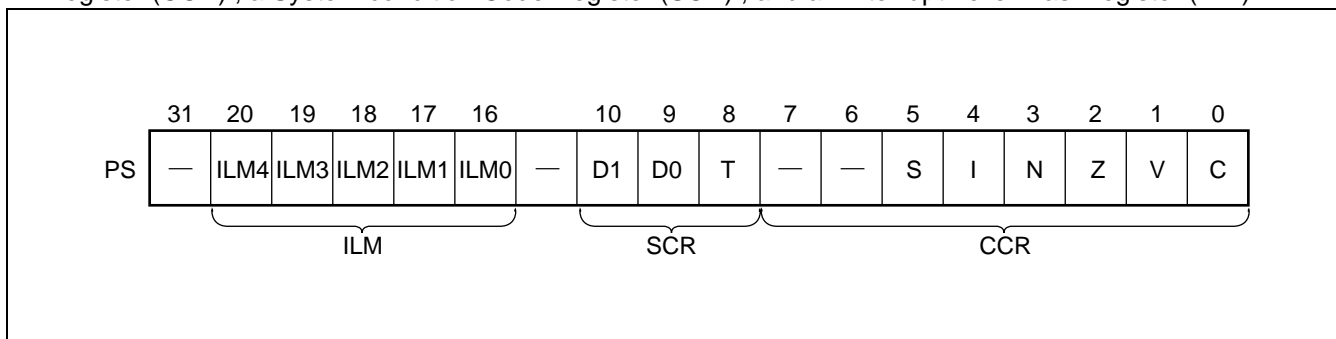

# MB91F155A/MB91155/MB91154

- **Condition Code Register (CCR)**

S flag : Designates the stack pointer for use as R15.

I flag : Controls enabling and disabling of user interrupt requests.

N flag : Indicates the sign when arithmetic operation results are considered to be an integer represented by 2's complement.

Z flag : Indicates if arithmetic results were "0."

V flag : Considers the operand used for an arithmetic operation to be an integer represented by 2's complement and indicates if the operation resulted in an overflow.

C flag : Indicates whether or not an arithmetic operation resulted in a carry or a borrow from the most significant bit.

- **System condition Code Register (SCR)**

T flag : Designates whether or not to enable step trace trap.

- **Interrupt Level Mask register (ILM)**

ILM4 to ILM0 : Holds an interrupt level mask value to be used for level masking.

An interrupt request is accepted only if the corresponding interrupt level among interrupt requests input to the CPU is higher than the value indicated by the ILM register.

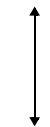
ILM4	ILM3	ILM2	ILM1	ILM0	Interrupt level	High-Low
0	0	0	0	0	0	Higher  Lower
⋮					⋮	
0	1	0	0	0	15	
⋮					⋮	
1	1	1	1	1	31	

# MB91F155A/MB91155/MB91154

## ■ GENERAL-PURPOSE REGISTERS

General-purpose registers are CPU registers R0 through R15 and used as accumulators during various operations and as memory access pointers (fields indicating addresses) .

### • Register Bank Configuration

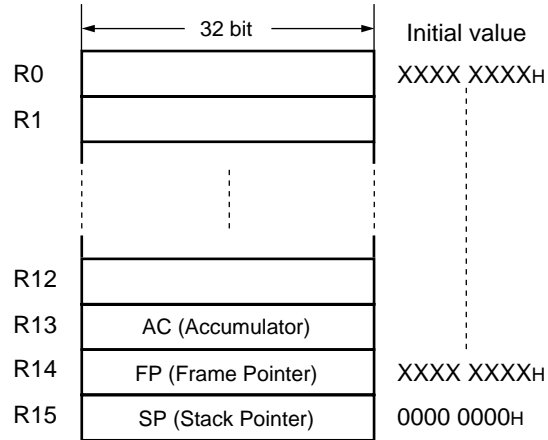

Of the 16 general-purpose registers, the following registers are assumed for specific applications. For this reason, some instructions are enhanced.

- R13 : Virtual accumulator (AC)
- R14 : Frame pointer (FP)
- R15 : Stack pointer (SP)

Initial values to which R0 through R14 are reset are not defined. The initial value of R15 is 0000 0000H (the SSP value) .

# MB91F155A/MB91155/MB91154

## ■ SETTING MODE

### 1. Mode Pins

As shown in Table 1 three pins, MD2, 1, and 0 are used to indicate an operation.

**Table 1 Mode pins and set modes**

Mode pin			Mode name	Reset vector access area	External data bus width	
MD2	MD1	MD0				
0	0	0	External vector mode 0	External	8 bits	External ROM bus mode
0	0	1	External vector mode 1	External	16 bits	
0	1	0	External vector mode 2	External	32 bits	Not available on this product type
0	1	1	External vector mode	Internal	(Mode register)	Single-chip mode
1	—	—	—	—	—	Not available

### 2. Mode Data

The data which the CPU writes to “0000 07FF<sub>H</sub>” after reset is called mode data.

It is the mode register (MODR) that exists at “0000 07FF<sub>H</sub>.” Once a mode is set in this register, operations will take place in that mode. The mode register can be written only once after reset.

The mode specified in the register is enabled immediately after it is written.

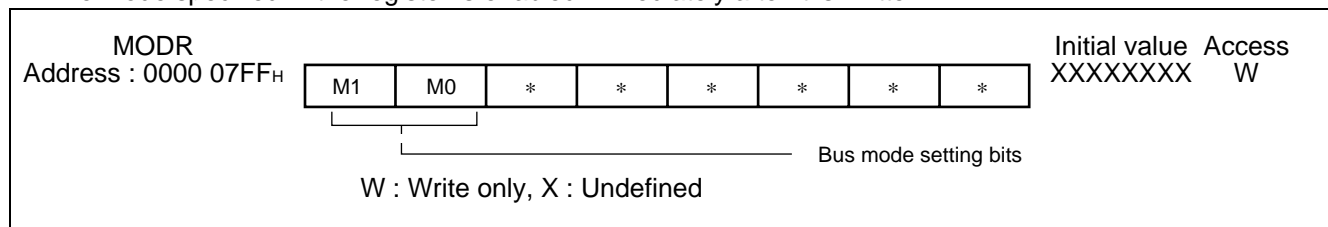

[bits 7 and 6] : M1, M0

These are bus mode setting bits. Specify the bus mode to be set to after writing to the mode register.

M1	M0	Function	Remarks
0	0	Single-chip mode	
0	1	Internal ROM-external bus mode	
1	0	External ROM-external bus mode	
1	1	—	Setting not allowed

[bits 5 to 0] : \*

These bits are reserved for the system.

“0” should be written to these bits at all times.



# MB91F155A/MB91155/MB91154

## [Precautions When Writing to the MODR]

Before writing to the MODR, be sure to set AMD0 through 5 and determine the bus width in each CS (Chip Select) area.

The MODR does not have bus width setting bits.

The bus width value set with mode pins MD2 through 0 is enabled before writing to the MODR and the bus width value set with BW1 and 0 of AMD0 through 5 is enabled after writing to the MODR.

For example, the external reset vector is normally executed with area 0 (the area where CS0 is active) and the bus width at that time is determined by pins MD 2 through 0. Suppose that the bus width is set to 32 or 16 bits in MD2 though 0 but no value is specified in AMD 0. If the MODR is written in this state, area 0 then switches to 8-bit bus mode and operates the bus since the initial bus width in AMD0 is set to 8 bits. This causes a malfunction.

In order to prevent this type of problem, AMD0 through 5 must always be set before writing to the MODR.

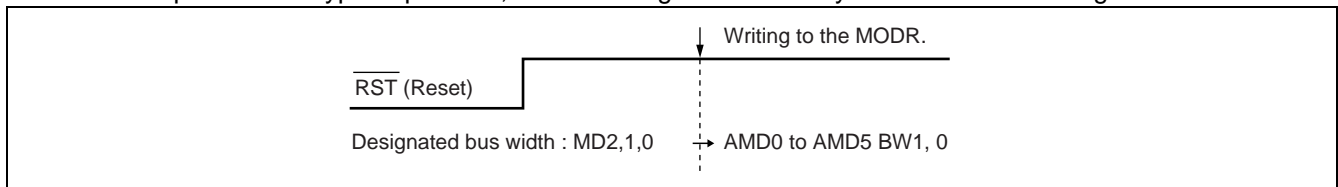

# MB91F155A/MB91155/MB91154

## ■ I/O MAP

Address	Register				Block
	+0	+1	+2	+3	
00000H	PDR3 (R/W) XXXXXXXX	PDR2 (R/W) XXXXXXXX	—		Port Data Register
00004H	—	PDR6 (R/W) XXXXXXXX	PDR5 (R/W) XXXXXXXX	PDR4 (R/W) XXXXXXXX	
00008H	—			PDR8 (R/W) - XXXXXXX	
0000CH	—				
00010H	PDRF (R/W) --- XXXXX	PDRE (R/W) XXXXXXXX	PDRD (R/W) XXXXXXXX	PDRC (R/W) XXXXXXXX	
00014H	PDRJ (R/W) ----- 11	PDR I (R/W) - - XXXXXXX	PDRH (R/W) - - XXXXXXX	PDRG (R/W) - - XXXXXXX	
00018H	—		PDRL (R/W) XXXXXXXX	PDRK (R/W) XXXXXXXX	
0001CH	SSR0 (R, R/W) 00001000	SIDR0/SODR0 (R, W) XXXXXXXX	SCR0 (R/W, W) 00000100	SMR0 (R/W) 00000 - 00	UART0
00020H	SSR1 (R, R/W) 00001000	SIDR1/SODR1 (R, W) XXXXXXXX	SCR1 (R/W, W) 00000100	SMR1 (R/W) 00000 - 00	UART1
00024H	SSR2 (R, R/W) 00001000	SIDR2/SODR2 (R, W) XXXXXXXX	SCR2 (R/W, W) 00000100	SMR2 (R/W) 00000 - 00	UART2
00028H	SSR3 (R, R/W) 00001000	SIDR3/SODR3 (R, W) XXXXXXXX	SCR3 (R/W, W) 00000100	SMR3 (R/W) 00000 - 00	UART3
0002CH	TMRLR0 (W) XXXXXXXX XXXXXXX		TMR0 (R) XXXXXXXX XXXXXXX		Reload Timer 0
00030H	—		TMCSR0 (R/W) ---- 0000 00000000		
00034H	TMRLR1 (W) XXXXXXXX XXXXXXX		TMR1 (R) XXXXXXXX XXXXXXX		Reload Timer 1
00038H	—		TMCSR1 (R/W) ---- 0000 00000000		
0003CH	TMRLR2 (W) XXXXXXXX XXXXXXX		TMR2 (R) XXXXXXXX XXXXXXX		Reload Timer 2
00040H	—		TMCSR2 (R/W) ---- 0000 00000000		

(Continued)

# MB91F155A/MB91155/MB91154

Address	Register				Block
000044 <sub>H</sub>	TMRLR3 (W) XXXXXXXX XXXXXXXX		TMR3 (R) XXXXXXXX XXXXXXXX		Reload Timer 3
000048 <sub>H</sub>	—		TMCSR3 (R/W) ---- 0000 00000000		
00004C <sub>H</sub>	CDCR1 (R/W) 0 --- 0000	—	CDCR0 (R/W) 0 --- 0000	—	Communications prescaler 1
000050 <sub>H</sub>	CDCR3 (R/W) 0 --- 0000	—	CDCR2 (R/W) 0 --- 0000	—	
000054 <sub>H</sub> to 000058 <sub>H</sub>	—				Reserved
00005C <sub>H</sub>	RCR1 (W) 00000000	RCR0 (W) 00000000	UDCR1 (R) 00000000	UDCR0 (R) 00000000	8/16 bit U/D Counter
000060 <sub>H</sub>	CCR0 (R/W) 00000000	CCRL0 (R/W, W) - 000X000	—	CSR0 (R/W, R) 00000000	
000064 <sub>H</sub>	CCR1 (R/W) - 0000000	CCRL1 (R/W, W) - 000X000	—	CSR1 (R/W, R) 00000000	
000068 <sub>H</sub>	IPCP1 (R) XXXXXXXX XXXXXXXX		IPCP0 (R) XXXXXXXX XXXXXXXX		16 bit ICU
00006C <sub>H</sub>	IPCP3 (R) XXXXXXXX XXXXXXXX		IPCP2 (R) XXXXXXXX XXXXXXXX		
000070 <sub>H</sub>	—	ICS23 (R/W) 00000000	—	ICS01 (R/W) 00000000	
000074 <sub>H</sub>	OCCP1 (R/W) XXXXXXXX XXXXXXXX		OCCP0 (R/W) XXXXXXXX XXXXXXXX		16 bit OCU
000078 <sub>H</sub>	OCCP3 (R/W) XXXXXXXX XXXXXXXX		OCCP2 (R/W) XXXXXXXX XXXXXXXX		
00007C <sub>H</sub>	OCCP5 (R/W) XXXXXXXX XXXXXXXX		OCCP4 (R/W) XXXXXXXX XXXXXXXX		
000080 <sub>H</sub>	OCCP7 (R/W) XXXXXXXX XXXXXXXX		OCCP6 (R/W) XXXXXXXX XXXXXXXX		
000084 <sub>H</sub>	OCS2, 3 (R/W) XXX00000 0000XX00		OCS0, 1 (R/W) XXX00000 0000XX00		
000088 <sub>H</sub>	OCS6, 7 (R/W) XXX00000 0000XX00		OCS4, 5 (R/W) XXX00000 0000XX00		
00008C <sub>H</sub>	TCDT (R/W) 00000000 00000000		TCCS (R/W) 0 - - - - - 00000000		
000090 <sub>H</sub>	STPR0 (R/W) 0000 - - - -	STPR1 (R/W) 00000000	STPR2 (R/W) 000000 - -	—	Stop Register 0, 1, 2
000094 <sub>H</sub>	GCN1 (R/W) 00110010 00010000		—	GCN2 (R/W) 00000000	PPG ctl

(Continued)

# MB91F155A/MB91155/MB91154

Address	Register				Block
000098 <sub>H</sub>	PTMR0 (R) 11111111 11111111		PCSR0 (W) XXXXXXXX XXXXXXXX		PPG0
00009C <sub>H</sub>	PDUT0 (W) XXXXXXXX XXXXXXXX		PCNH0 (R/W) 0000000 -	PCNL0 (R/W) 00000000	
0000A0 <sub>H</sub>	PTMR1 (R) 11111111 11111111		PCSR1 (W) XXXXXXXX XXXXXXXX		PPG1
0000A4 <sub>H</sub>	PDUT1 (W) XXXXXXXX XXXXXXXX		PCNH1 (R/W) 0000000 -	PCNL1 (R/W) 00000000	
0000A8 <sub>H</sub>	PTMR2 (R) 11111111 11111111		PCSR2 (W) XXXXXXXX XXXXXXXX		PPG2
0000AC <sub>H</sub>	PDUT2 (W) XXXXXXXX XXXXXXXX		PCNH2 (R/W) 0000000 -	PCNL2 (R/W) 00000000	
0000B0 <sub>H</sub>	PTMR3 (R) 11111111 11111111		PCSR3 (W) XXXXXXXX XXXXXXXX		PPG3
0000B4 <sub>H</sub>	PDUT3 (W) XXXXXXXX XXXXXXXX		PCNH3 (R/W) 0000000 -	PCNL3 (R/W) 00000000	
0000B8 <sub>H</sub>	PTMR4 (R) 11111111 11111111		PCSR4 (W) XXXXXXXX XXXXXXXX		PPG4
0000BC <sub>H</sub>	PDUT4 (W) XXXXXXXX XXXXXXXX		PCNH4 (R/W) 0000000 -	PCNL4 (R/W) 00000000	
0000C0 <sub>H</sub>	PTMR5 (R) 11111111 11111111		PCSR5 (W) XXXXXXXX XXXXXXXX		PPG5
0000C4 <sub>H</sub>	PDUT5 (W) XXXXXXXX XXXXXXXX		PCNH5 (R/W) 0000000 -	PCNL5 (R/W) 00000000	
0000C8 <sub>H</sub>	EIRR0 (R/W) 00000000	ENIR0 (R/W) 00000000	EIRR1 (R/W) 00000000	ENIR1 (R/W) 00000000	Ext int
0000CC <sub>H</sub>	ELVR0 (R/W) 00000000 00000000		ELVR1 (R/W) 00000000 00000000		
0000D0 <sub>H</sub> to 0000D8 <sub>H</sub>	—				Reserved
0000DC <sub>H</sub>	—	DACR2 (R/W) ----- 0	DACR1 (R/W) ----- 0	DACR0 (R/W) ----- 0	D/A Converter
0000E0 <sub>H</sub>	—	DADR2 (R/W) XXXXXXXX	DADR1 (R/W) XXXXXXXX	DADR0 (R/W) XXXXXXXX	
0000E4 <sub>H</sub>	ADCR (R, W) 00101- XX XXXXXXXX		ADCS1 (R/W, W) 00000000	ADCS0 (R/W) 00000000	A/D Converter (Sequential type)
0000E8 <sub>H</sub>	—			AICK (R/W) 00000000	Analog Input Control
0000EC <sub>H</sub> to 0000F0 <sub>H</sub>	—				Reserved

(Continued)

# MB91F155A/MB91155/MB91154

Address	Register				Block
0000F4 <sub>H</sub>	PCRI (R/W) -- 000000	PCRH (R/W) -- 000000	PCRD (R/W) 00000000	PCRC (R/W) 00000000	Pull Up Control
0000F8 <sub>H</sub>	OCRI (R/W) -- 000000	OCRH (R/W) -- 000000	—		Opendrain Control
0000FC <sub>H</sub>	DDRF (R/W) --- 00000	DDRE (R/W) 00000000	DDRD (R/W) 00000000	DDRC (R/W) 00000000	Data Direction Register
000100 <sub>H</sub>	—	DDRI (R/W) - 0000000	DDRH (R/W) -- 000000	DDRG (R/W) -- 000000	
000104 <sub>H</sub>	—		DDRL (R/W) 00000000	DDRK (R/W) 00000000	
000108 <sub>H</sub> to 00011C <sub>H</sub>	—				Reserved
000120 <sub>H</sub>	IBCR (R/W) 00000000	IBSR (R) 00000000	IADR (R/W) - XXXXXXX	ICCR (R/W) -- 0XXXXX	I <sup>2</sup> C Interface
000124 <sub>H</sub>	—	IDAR (R/W) XXXXXXXX	—		
000128 <sub>H</sub> to 0001FC <sub>H</sub>	—				Reserved
000200 <sub>H</sub>	DPDP (R/W) ----- - 0000000				DMAC
000204 <sub>H</sub>	DACSR (R/W) 00000000 00000000 00000000 00000000				
000208 <sub>H</sub>	DATCR (R/W) XXXXXXXX XXXX0000 XXXX0000 XXXX0000				
00020C <sub>H</sub>	—				Reserved
000210 <sub>H</sub>	CAC (R/W) 00000000	CA1 (R/W) -- XXXXXX	CA2 (R/W) -- XXXXXX	CA3 (R/W) --- XXXXX	Calendar
000214 <sub>H</sub>	CA4 (R/W) --- XXXXX	CA5 (R/W) ----- XXX	CA6 (R/W) ----- XXXX	CA7 (R/W) - XXXXXXX	
000218 <sub>H</sub>	—				Reserved
00021C <sub>H</sub>	—			CAS (R/W) 0 ----- 0	Calendar
000220 <sub>H</sub> to 0003EC <sub>H</sub>	—				Reserved

(Continued)

# MB91F155A/MB91155/MB91154

Address	Register				Block
0003F0H	BSD0 (W) XXXXXXXX XXXXXXXX XXXXXXXX XXXXXXXX				Bit Search Module
0003E4H	BSD1 (R/W) XXXXXXXX XXXXXXXX XXXXXXXX XXXXXXXX				
0003F8H	BSDC (W) XXXXXXXX XXXXXXXX XXXXXXXX XXXXXXXX				
0003FCH	BSRR (R) XXXXXXXX XXXXXXXX XXXXXXXX XXXXXXXX				
000400H	ICR00 (R/W) ---- 1111	ICR01 (R/W) ---- 1111	ICR02 (R/W) ---- 1111	ICR03 (R/W) ---- 1111	Interrupt Control unit
000404H	ICR04 (R/W) ---- 1111	ICR05 (R/W) ---- 1111	ICR06 (R/W) ---- 1111	ICR07 (R/W) ---- 1111	
000408H	ICR08 (R/W) ---- 1111	ICR09 (R/W) ---- 1111	ICR10 (R/W) ---- 1111	ICR11 (R/W) ---- 1111	
00040CH	ICR12 (R/W) ---- 1111	ICR13 (R/W) ---- 1111	ICR14 (R/W) ---- 1111	ICR15 (R/W) ---- 1111	
000410H	ICR16 (R/W) ---- 1111	ICR17 (R/W) ---- 1111	ICR18 (R/W) ---- 1111	ICR19 (R/W) ---- 1111	
000414H	ICR20 (R/W) ---- 1111	ICR21 (R/W) ---- 1111	ICR22 (R/W) ---- 1111	ICR23 (R/W) ---- 1111	
000418H	ICR24 (R/W) ---- 1111	ICR25 (R/W) ---- 1111	ICR26 (R/W) ---- 1111	ICR27 (R/W) ---- 1111	
00041CH	ICR28 (R/W) ---- 1111	ICR29 (R/W) ---- 1111	ICR30 (R/W) ---- 1111	ICR31 (R/W) ---- 1111	
000420H	ICR32 (R/W) ---- 1111	ICR33 (R/W) ---- 1111	ICR34 (R/W) ---- 1111	ICR35 (R/W) ---- 1111	
000424H	ICR36 (R/W) ---- 1111	ICR37 (R/W) ---- 1111	ICR38 (R/W) ---- 1111	ICR39 (R/W) ---- 1111	
000428H	ICR40 (R/W) ---- 1111	ICR41 (R/W) ---- 1111	ICR42 (R/W) ---- 1111	ICR43 (R/W) ---- 1111	
00042CH	ICR44 (R/W) ---- 1111	ICR45 (R/W) ---- 1111	ICR46 (R/W) ---- 1111	ICR47 (R/W) ---- 1111	
000430H	DICR (R/W) ----- 0	HRCL (R/W) ---- 1111	—		Delay int
000434H to 00047CH	—				Reserved
000480H	RSRR/WTCR (R, W) 1-XXX-00	STCR (R/W, W) 000111--	PDRR (R/W) ---- 0000	CTBR (W) XXXXXXXX	Clock Control unit
000484H	GCR (R/W, R) 110011-1	WPR (W) XXXXXXXX	—		

(Continued)

# MB91F155A/MB91155/MB91154

Address	Register				Block
000488H	PTCR (R/W) 00XX0XXX		—		PLL Control
00048CH to 0005FCH	—				Reserved
000600H	DDR3 (W) 00000000	DDR2 (W) 00000000	—	—	Data Direction Register
000604H	—	DDR6 (W) 00000000	DDR5 (W) 00000000	DDR4 (W) 00000000	
000608H	—			DDR8 (W) - 0000000	
00060CH	ASR1 (W) 00000000 00000001		AMR1 (W) 00000000 00000000		T-unit
000610H	ASR2 (W) 00000000 00000010		AMR2 (W) 00000000 00000000		
000614H	ASR3 (W) 00000000 00000011		AMR3 (W) 00000000 00000000		
000618H	ASR4 (W) 00000000 00000100		AMR4 (W) 00000000 00000000		
00061CH	ASR5 (W) 00000000 00000101		AMR5 (W) 00000000 00000000		
000620H	AMD0 (R/W) --- 00111	AMD1 (R/W) 0 -- 00000	AMD32 (R/W) 00000000	AMD4 (R/W) 0 -- 00000	
000624H	AMD5 (R/W) 0 -- 00000	—			
000628H	EPCR0 (W) ---- 1100 -1111111		EPCR1 (W) ----- 11111111		
00062CH	—				Reserved
000630H	—	PCR6 (R/W) 00000000	—		Pull Up Control
000634H to 0007BCH	—				Reserved
0007C0H	FLCR (R/W, R) 000XXX0	—			FLASH Control
0007C4H	FWTC (R/W, W) ----- 000	—			
0007C8H to 0007F8H	—				Reserved

(Continued)

# MB91F155A/MB91155/MB91154

(Continued)

Address	Register			Block
0007FC <sub>H</sub>	—	LER (W) -----000	MODR (W) XXXXXXXX	Little Endian Register Mode Register

Note : Do not execute RMW instructions on registers having a write-only bit.

RMW instructions (RMW : Read Modify Write)

AND Rj, @Ri	OR Rj, @Ri	EOR Rj, @Ri
ANDH Rj, @Ri	ORH Rj, @Ri	EORH Rj, @Ri
ANDB Rj, @Ri	ORB Rj, @Ri	EORB Rj, @Ri
BANDL #u4, @Ri	BORL #u4, @Ri	BEORL #u4, @Ri
BANDH #u4, @Ri	BORH #u4, @Ri	BEORH #u4, @Ri

Data is undefined in “Reserved” or (—) areas.

( ) : Access  
 R/W : Read/Write enabled  
 R : Read only  
 W : Write only  
 — : Not in use  
 X : Undefined



# MB91F155A/MB91155/MB91154

## ■ INTERRUPT FACTORS AND ASSIGNMENT OF INTERRUPT VECTORS AND RESISTERS

Factor	Interrupt No.		Interrupt level	Offset	Default TBR address
	Decimal	Hex.			
Reset	0	00	—	3FC <sub>H</sub>	000FFFFC <sub>H</sub>
Reserved for the system	1	01	—	3F8 <sub>H</sub>	000FFFF8 <sub>H</sub>
Reserved for the system	2	02	—	3F4 <sub>H</sub>	000FFFF4 <sub>H</sub>
Reserved for the system	3	03	—	3F0 <sub>H</sub>	000FFFF0 <sub>H</sub>
Reserved for the system	4	04	—	3EC <sub>H</sub>	000FFFE <sub>C</sub>
Reserved for the system	5	05	—	3E8 <sub>H</sub>	000FFFE8 <sub>H</sub>
Reserved for the system	6	06	—	3E4 <sub>H</sub>	000FFFE4 <sub>H</sub>
Reserved for the system	7	07	—	3E0 <sub>H</sub>	000FFFE0 <sub>H</sub>
Reserved for the system	8	08	—	3DC <sub>H</sub>	000FFFD <sub>C</sub>
Reserved for the system	9	09	—	3D8 <sub>H</sub>	000FFFD8 <sub>H</sub>
Reserved for the system	10	0A	—	3D4 <sub>H</sub>	000FFFD4 <sub>H</sub>
Reserved for the system	11	0B	—	3D0 <sub>H</sub>	000FFFD0 <sub>H</sub>
Reserved for the system	12	0C	—	3CC <sub>H</sub>	000FFFDC <sub>H</sub>
Reserved for the system	13	0D	—	3C8 <sub>H</sub>	000FFFC8 <sub>H</sub>
Undefined instruction exception	14	0E	—	3C4 <sub>H</sub>	000FFFC4 <sub>H</sub>
Reserved for the system	15	0F	—	3C0 <sub>H</sub>	000FFFC0 <sub>H</sub>
External interrupt 0	16	10	ICR00	3BC <sub>H</sub>	000FFFBC <sub>H</sub>
External interrupt 1	17	11	ICR01	3B8 <sub>H</sub>	000FFFB8 <sub>H</sub>
External interrupt 2	18	12	ICR02	3B4 <sub>H</sub>	000FFFB4 <sub>H</sub>
External interrupt 3	19	13	ICR03	3B0 <sub>H</sub>	000FFFB0 <sub>H</sub>
External interrupt 4	20	14	ICR04	3AC <sub>H</sub>	000FFFA <sub>C</sub>
External interrupt 5	21	15	ICR05	3A8 <sub>H</sub>	000FFFA8 <sub>H</sub>
External interrupt 6	22	16	ICR06	3A4 <sub>H</sub>	000FFFA4 <sub>H</sub>
External interrupt 7	23	17	ICR07	3A0 <sub>H</sub>	000FFFA0 <sub>H</sub>
External interrupts 8 - 15	24	18	ICR08	39C <sub>H</sub>	000FFF9 <sub>C</sub>
Reserved for the system	25	19	—	398 <sub>H</sub>	000FFF98 <sub>H</sub>
UART0 (receiving complete)	26	1A	ICR10	394 <sub>H</sub>	000FFF94 <sub>H</sub>
UART1 (receiving complete)	27	1B	ICR11	390 <sub>H</sub>	000FFF90 <sub>H</sub>
UART2 (receiving complete)	28	1C	ICR12	38C <sub>H</sub>	000FFF8 <sub>C</sub>
UART3 (receiving complete)	29	1D	ICR13	388 <sub>H</sub>	000FFF88 <sub>H</sub>
Reserved for the system	30	1E	—	384 <sub>H</sub>	000FFF84 <sub>H</sub>
UART0 (sending complete)	31	1F	ICR15	380 <sub>H</sub>	000FFF80 <sub>H</sub>
UART1 (sending complete)	32	20	ICR16	37C <sub>H</sub>	000FFF7 <sub>C</sub>
UART2 (sending complete)	33	21	ICR17	378 <sub>H</sub>	000FFF78 <sub>H</sub>

(Continued)

# MB91F155A/MB91155/MB91154

Factor	Interrupt No.		Interrupt level	Offset	Default TBR address
	Decimal	Hex.			
UART3 (sending complete)	34	22	ICR18	374 <sub>H</sub>	000FFF74 <sub>H</sub>
I <sup>2</sup> C	35	23	ICR19	370 <sub>H</sub>	000FFF70 <sub>H</sub>
DMAC (End, Error)	36	24	ICR20	36C <sub>H</sub>	000FFF6C <sub>H</sub>
Reload timer 0	37	25	ICR21	368 <sub>H</sub>	000FFF68 <sub>H</sub>
Reload timer 1	38	26	ICR22	364 <sub>H</sub>	000FFF64 <sub>H</sub>
Reload timer 2	39	27	ICR23	360 <sub>H</sub>	000FFF60 <sub>H</sub>
Reload timer 3	40	28	ICR24	35C <sub>H</sub>	000FFF5C <sub>H</sub>
A/D (sequential type)	42	2A	ICR26	354 <sub>H</sub>	000FFF54 <sub>H</sub>
PPG0	43	2B	ICR27	350 <sub>H</sub>	000FFF50 <sub>H</sub>
PPG1	44	2C	ICR28	34C <sub>H</sub>	000FFF4C <sub>H</sub>
PPG2	45	2D	ICR29	348 <sub>H</sub>	000FFF48 <sub>H</sub>
PPG3	46	2E	ICR30	344 <sub>H</sub>	000FFF44 <sub>H</sub>
PPG4	47	2F	ICR31	340 <sub>H</sub>	000FFF40 <sub>H</sub>
PPG5	48	30	ICR32	33C <sub>H</sub>	000FFF3C <sub>H</sub>
U/Dcounter 0 (compare/underflow, overflow, up-down inversion)	49	31	ICR33	338 <sub>H</sub>	000FFF38 <sub>H</sub>
U/Dcounter 1 (compare/underflow, overflow, up-down inversion)	50	32	ICR34	334 <sub>H</sub>	000FFF34 <sub>H</sub>
ICU0 (Read)	51	33	ICR35	330 <sub>H</sub>	000FFF30 <sub>H</sub>
ICU1 (Read)	52	34	ICR36	32C <sub>H</sub>	000FFF2C <sub>H</sub>
ICU2 (Read)	53	35	ICR37	328 <sub>H</sub>	000FFF28 <sub>H</sub>
ICU3 (Read)	54	36	ICR38	324 <sub>H</sub>	000FFF24 <sub>H</sub>
OCU0 (Match)	55	37	ICR39	320 <sub>H</sub>	000FFF20 <sub>H</sub>
OCU1 (Match)	56	38	ICR40	31C <sub>H</sub>	000FFF1C <sub>H</sub>
OCU2 (Match)	57	39	ICR41	318 <sub>H</sub>	000FFF18 <sub>H</sub>
OCU3 (Match)	58	3A	ICR42	314 <sub>H</sub>	000FFF14
OCU4/5 (Match)	59	3B	ICR43	310 <sub>H</sub>	000FFF10 <sub>H</sub>
OCU6/7 (Match)	60	3C	ICR44	30C <sub>H</sub>	000FFF0C <sub>H</sub>
Reserved for the system	61	3D	—	308 <sub>H</sub>	000FFF08 <sub>H</sub>
16-bit free-run timer	62	3E	ICR46	304 <sub>H</sub>	000FFF04 <sub>H</sub>
Delay interrupt factor bit	63	3F	ICR47	300 <sub>H</sub>	000FFF00 <sub>H</sub>

(Continued)

# MB91F155A/MB91155/MB91154

(Continued)

Factor	Interrupt No.		Interrupt level	Offset	Default TBR address
	Decimal	Hex.			
Reserved for the system (used by REALOS*)	64	40	—	2FC <sub>H</sub>	000FFEFC <sub>H</sub>
Reserved for the system (used by REALOS*)	65	41	—	2F8 <sub>H</sub>	000FFE8 <sub>H</sub>
Reserved for the system	66	42	—	2F4 <sub>H</sub>	000FFE4 <sub>H</sub>
Reserved for the system	67	43	—	2F0 <sub>H</sub>	000FFE0 <sub>H</sub>
Reserved for the system	68	44	—	2EC <sub>H</sub>	000FEEC <sub>H</sub>
Reserved for the system	69	45	—	2E8 <sub>H</sub>	000FEE8 <sub>H</sub>
Reserved for the system	70	46	—	2E4 <sub>H</sub>	000FEE4 <sub>H</sub>
Reserved for the system	71	47	—	2E0 <sub>H</sub>	000FEE0 <sub>H</sub>
Reserved for the system	72	48	—	2DC <sub>H</sub>	000FEDC <sub>H</sub>
Reserved for the system	73	49	—	2D8 <sub>H</sub>	000FED8 <sub>H</sub>
Reserved for the system	74	4A	—	2D4 <sub>H</sub>	000FED4 <sub>H</sub>
Reserved for the system	75	4B	—	2D0 <sub>H</sub>	000FED0 <sub>H</sub>
Reserved for the system	76	4C	—	2CC <sub>H</sub>	000FECC <sub>H</sub>
Reserved for the system	77	4D	—	2C8 <sub>H</sub>	000FEC8 <sub>H</sub>
Reserved for the system	78	4E	—	2C4 <sub>H</sub>	000FEC4 <sub>H</sub>
Reserved for the system	79	4F	—	2C0 <sub>H</sub>	000FEC0 <sub>H</sub>
Used with the INT instruction	80 to 255	50 to FF	—	2BC <sub>H</sub> to 000 <sub>H</sub>	000FEB8 <sub>H</sub> to 000FFC00 <sub>H</sub>

\* : REALOS/FR uses 0X40 and 0X41 interrupts for system codes.

# MB91F155A/MB91155/MB91154

## ■ PERIPHERAL RESOURCES

### 1. I/O Port

#### (1) Port Block Diagram

This LSI is available as an I/O port when the resource associated with each pin is set not to use a pin for input/output.

The pin level is read from the port (PDR) when it is set for input. When the port is set for output, the value in the data register is read. The same also applies to reload by read modify write.

When switching from input to output, output data is set in the data register beforehand. However, if a read modify write instruction (such as bit set) is used at that time, keep in mind that it is the input data from the pin that is read, not the latch value of the data register.

#### • Basic I/O Port

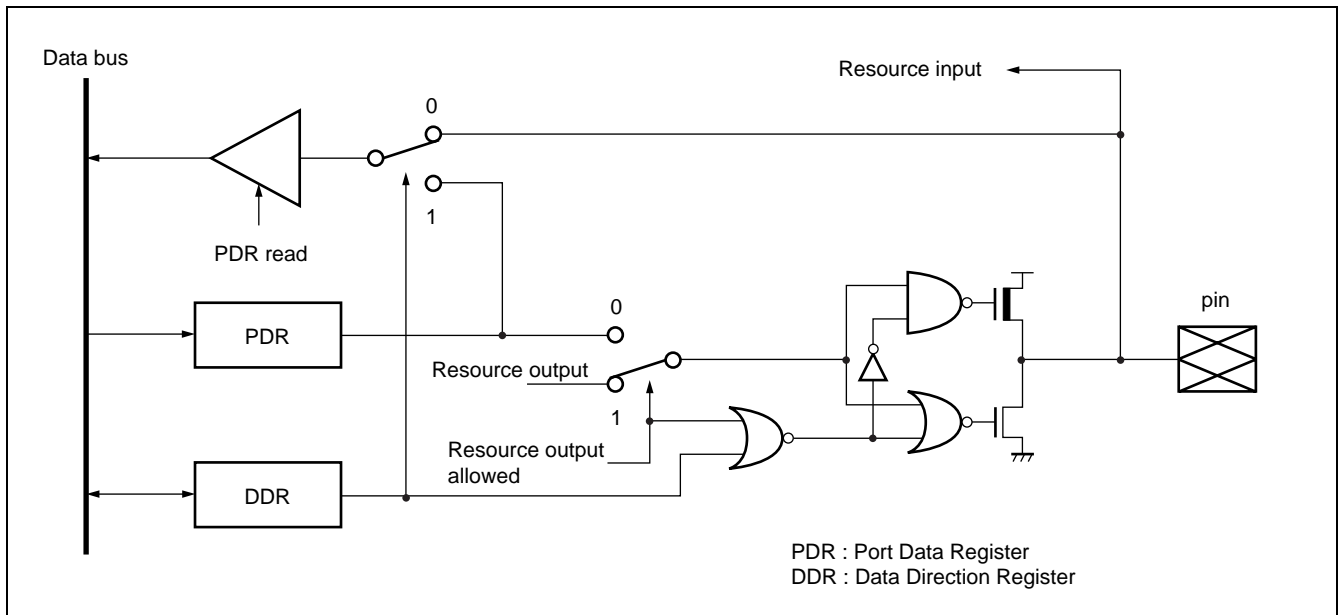

Figure PORT-1 Basic port block

The I/O port consists of the PDR (Port Data Register) and the DDR (Data Direction Register) .

In input mode (DDR = "0") → PDR read : Reads the level of the corresponding external pin.

PDR write : Writes the set value to the PDR.

In output mode (DDR = "1") → PDR read : Reads the PDR value.

PDR write : Outputs the PDR value to the corresponding external pin.

Notes : AIC controls switching between the resource and port of the analog pin (A/D) .

AICK (Analog Input Control register on port-K)

The register controls whether port K should be used for analog input or as a general-purpose port.

0 : General-purpose port

1 : Analog input (A/D)



# MB91F155A/MB91155/MB91154

- I/O Port (attached with the open drain output function and a pullup resistor)

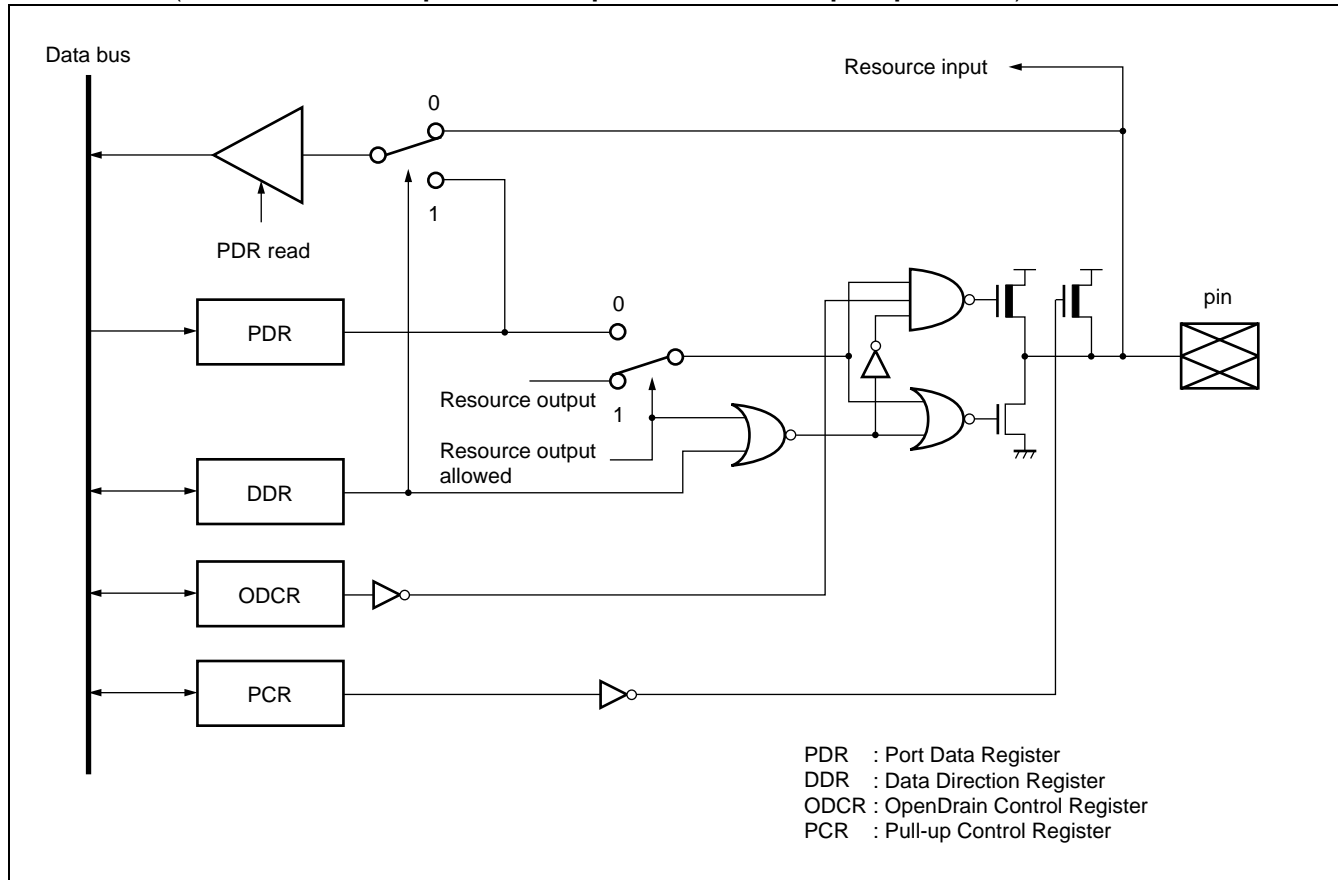

**Figure PORT-3 Port block attached with the open drain output function and a pullup resistor**

Notes : • Pullup resistor setup register (PCR) R/W

Controls turning the pullup resistor on/off.

0 : Pullup resistor disabled

1 : Pullup resistor enabled

• Open drain control register (ODCR) R/W

Controls open drain in output mode.

0 : Standard output port during output mode

1 : Open-drain output port during output mode

This register has no significance in input mode (output Hi-Z) . Input/output mode is determined by the direction register (DDR) .

• Priority is also given to the setting of the pullup resistor control register in stop mode.

• When a relevant pin is used as an external bus pin, neither function is available. Do not write "1" to either register.



# MB91F155A/MB91155/MB91154

## (2) Register Descriptions

### • Port Data Register (PDR)

PDR2	7	6	5	4	3	2	1	0	Initial value	Access
Address : 000001H	P27	P26	P25	P24	P23	P22	P21	P20	XXXXXXXX <sub>B</sub>	R/W
PDR3	7	6	5	4	3	2	1	0	Initial value	Access
Address : 000000H	P37	P36	P35	P34	P33	P32	P31	P30	XXXXXXXX <sub>B</sub>	R/W
PDR4	7	6	5	4	3	2	1	0	Initial value	Access
Address : 000007H	P47	P46	P45	P44	P43	P42	P41	P40	XXXXXXXX <sub>B</sub>	R/W
PDR5	7	6	5	4	3	2	1	0	Initial value	Access
Address : 000006H	P57	P56	P55	P54	P53	P52	P51	P50	XXXXXXXX <sub>B</sub>	R/W
PDR6	7	6	5	4	3	2	1	0	Initial value	Access
Address : 000005H	P67	P66	P65	P64	P63	P62	P61	P60	XXXXXXXX <sub>B</sub>	R/W
PDR8	7	6	5	4	3	2	1	0	Initial value	Access
Address : 00000BH	—	P86	P85	P84	P83	P82	P81	P80	- XXXXXXX <sub>B</sub>	R/W
PDRC	7	6	5	4	3	2	1	0	Initial value	Access
Address : 000013H	PC7	PC6	PC5	PC4	PC3	PC2	PC1	PC0	XXXXXXXX <sub>B</sub>	R/W
PDRD	7	6	5	4	3	2	1	0	Initial value	Access
Address : 000012H	PD7	PD6	PD5	PD4	PD3	PD2	PD1	PD0	XXXXXXXX <sub>B</sub>	R/W
PDRE	7	6	5	4	3	2	1	0	Initial value	Access
Address : 000011H	PE7	PE6	PE5	PE4	PE3	PE2	PE1	PE0	XXXXXXXX <sub>B</sub>	R/W
PDRF	7	6	5	4	3	2	1	0	Initial value	Access
Address : 000010H	—	—	—	PF4	PF3	PF2	PF1	PF0	--- XXXXX <sub>B</sub>	R/W
PDRG	7	6	5	4	3	2	1	0	Initial value	Access
Address : 000017H	—	—	PG5	PG4	PG3	PG2	PG1	PG0	-- XXXXXX <sub>B</sub>	R/W
PDRH	7	6	5	4	3	2	1	0	Initial value	Access
Address : 000016H	—	—	PH5	PH4	PH3	PH2	PH1	PH0	-- XXXXXX <sub>B</sub>	R/W
PDRI	7	6	5	4	3	2	1	0	Initial value	Access
Address : 000015H	—	—	PI5	PI4	PI3	PI2	PI1	PI0	-- XXXXXX <sub>B</sub>	R/W
PDRJ	7	6	5	4	3	2	1	0	Initial value	Access
Address : 000014H	—	—	—	—	—	—	PJ1	PJ0	----- 11 <sub>B</sub>	R/W
PDRK	7	6	5	4	3	2	1	0	Initial value	Access
Address : 00001BH	PK7	PK6	PK5	PK4	PK3	PK2	PK1	PK0	XXXXXXXX <sub>B</sub>	R/W
PDRL	7	6	5	4	3	2	1	0	Initial value	Access
Address : 00001AH	PL7	PL6	PL5	PL4	PL3	PL2	PL1	PL0	XXXXXXXX <sub>B</sub>	R/W

PDR2 to PDRL are the I/O data registers of the I/O port.  
 Input/output is controlled with corresponding DDR2 to DDRL.  
 R/W : Read/Write enabled, X : Undefined, — : Not in use



# MB91F155A/MB91155/MB91154

• **Data Direction Register (DDR)**

<b>DDR2</b>		7	6	5	4	3	2	1	0	Initial value	Access
Address : 000601 <sub>H</sub>		P27	P26	P25	P24	P23	P22	P21	P20	0000000 <sub>B</sub>	W
<b>DDR3</b>		7	6	5	4	3	2	1	0	Initial value	Access
Address : 000600 <sub>H</sub>		P37	P36	P35	P34	P33	P32	P31	P30	0000000 <sub>B</sub>	W
<b>DDR4</b>		7	6	5	4	3	2	1	0	Initial value	Access
Address : 000607 <sub>H</sub>		P47	P46	P45	P44	P43	P42	P41	P40	0000000 <sub>B</sub>	W
<b>DDR5</b>		7	6	5	4	3	2	1	0	Initial value	Access
Address : 000606 <sub>H</sub>		P57	P56	P55	P54	P53	P52	P51	P50	0000000 <sub>B</sub>	W
<b>DDR6</b>		7	6	5	4	3	2	1	0	Initial value	Access
Address : 000605 <sub>H</sub>		P67	P66	P65	P64	P63	P62	P61	P60	0000000 <sub>B</sub>	W
<b>DDR8</b>		7	6	5	4	3	2	1	0	Initial value	Access
Address : 00060B <sub>H</sub>		—	P86	P85	P84	P83	P82	P81	P80	- 0000000 <sub>B</sub>	W
<b>DDRC</b>		7	6	5	4	3	2	1	0	Initial value	Access
Address : 0000FF <sub>H</sub>		PC7	PC6	PC5	PC4	PC3	PC2	PC1	PC0	0000000 <sub>B</sub>	R/W
<b>DDRD</b>		7	6	5	4	3	2	1	0	Initial value	Access
Address : 0000FE <sub>H</sub>		PD7	PD6	PD5	PD4	PD3	PD2	PD1	PD0	0000000 <sub>B</sub>	R/W
<b>DDRE</b>		7	6	5	4	3	2	1	0	Initial value	Access
Address : 0000FD <sub>H</sub>		PE7	PE6	PE5	PE4	PE3	PE2	PE1	PE0	0000000 <sub>B</sub>	R/W
<b>DDRF</b>		7	6	5	4	3	2	1	0	Initial value	Access
Address : 0000FC <sub>H</sub>		—	—	—	PF4	PF3	PF2	PF1	PF0	- - - 00000 <sub>B</sub>	R/W
<b>DDRG</b>		7	6	5	4	3	2	1	0	Initial value	Access
Address : 000103 <sub>H</sub>		—	—	PG5	PG4	PG3	PG2	PG1	PG0	- - 00000 <sub>B</sub>	R/W
<b>DDRH</b>		7	6	5	4	3	2	1	0	Initial value	Access
Address : 000102 <sub>H</sub>		—	—	PH5	PH4	PH3	PH2	PH1	PH0	- - 00000 <sub>B</sub>	R/W
<b>DDRI</b>		7	6	5	4	3	2	1	0	Initial value	Access
Address : 000101 <sub>H</sub>		—	TEST	PI5	PI4	PI3	PI2	PI1	PI0	- 0000000 <sub>B</sub>	R/W
<b>DDRK</b>		7	6	5	4	3	2	1	0	Initial value	Access
Address : 000107 <sub>H</sub>		PK7	PK6	PK5	PK4	PK3	PK2	PK1	PK0	0000000 <sub>B</sub>	R/W
<b>DDRL</b>		7	6	5	4	3	2	1	0	Initial value	Access
Address : 000106 <sub>H</sub>		PL7	PL6	PL5	PL4	PL3	PL2	PL1	PL0	0000000 <sub>B</sub>	R/W

DDR2 to DDRL control the I/O direction of the I/O port by bit.

DDR = 0 : Port input

DDR = 1 : Port output

Note : DDRI's bit 6 is a test bit. Be sure to write "0" to the bit.

"0" is the value that is read.

R/W : Read/Write enabled, W : Write only, — : Not in use

# MB91F155A/MB91155/MB91154

## • Pull-up Control Register (PCR)

PCR6	7	6	5	4	3	2	1	0	Initial value	Access
Address : 000631 <sub>H</sub>	P67	P66	P65	P64	P63	P62	P61	P60	00000000 <sub>B</sub>	R/W

PCRC	7	6	5	4	3	2	1	0	Initial value	Access
Address : 0000F7 <sub>H</sub>	PC7	PC6	PC5	PC4	PC3	PC2	PC1	PC0	00000000 <sub>B</sub>	R/W

PCRD	7	6	5	4	3	2	1	0	Initial value	Access
Address : 0000F6 <sub>H</sub>	PD7	PD6	PD5	PD4	PD3	PD2	PD1	PD0	00000000 <sub>B</sub>	R/W

PCRH	7	6	5	4	3	2	1	0	Initial value	Access
Address : 0000F5 <sub>H</sub>	—	—	PH5	PH4	PH3	PH2	PH1	PH0	-- 000000 <sub>B</sub>	R/W

PCRI	7	6	5	4	3	2	1	0	Initial value	Access
Address : 0000F4 <sub>H</sub>	—	—	PI5	PI4	PI3	PI2	PI1	PI0	-- 000000 <sub>B</sub>	R/W

PCR6 to PCRI control the pullup resistor when the corresponding I/O port is in input mode.

PCR = 0 : Pullup resistor not available in input mode

PCR = 1 : Pullup resistor available in input mode

The register has no significance in output mode (a pullup resistor not available) .

## • Open Drain Control Register (ODCR)

OCRH	7	6	5	4	3	2	1	0	Initial value	Access
Address : 0000F9 <sub>H</sub>	—	—	PH5	PH4	PH3	PH2	PH1	PH0	-- 000000 <sub>B</sub>	R/W

OCRI	7	6	5	4	3	2	1	0	Initial value	Access
Address : 0000F8 <sub>H</sub>	—	—	PI5	PI4	PI3	PI2	PI1	PI0	-- 000000 <sub>B</sub>	R/W

OCRH and OCRI control open drain when the corresponding I/O port is in output mode.

OCR = 0 : Standard output port during output mode

OCR = 1 : Open drain output port during output mode

The register has no significance in input mode (output Hi-z) .

## • Analog Input Control Register (AICK)

AICK	7	6	5	4	3	2	1	0	Initial value	Access
Address : 0000EB <sub>H</sub>	PK7	PK6	PK5	PK4	PK3	PK2	PK1	PK0	00000000 <sub>B</sub>	R/W

The AICK controls each pin of a corresponding I/O port as follows :

AIC = 0 : Port input mode

AIC = 1 : Analog input mode

The register is reset to "0."

R/W : Read/Write enabled, — : Not in use

# MB91F155A/MB91155/MB91154

## 2. DMA Controller (DMAC)

The DMA controller is a module embedded in FR family devices, and performs DMA (direct memory access) transfer.

DMA transfer performed by the DMA controller transfers data without intervention of CPU, contributing to enhanced performance of the system.

- 8 channels
- Mode : single/block transfer, burst transfer and continuous transfer : 3 kinds of transfer
- Transfer all through the area
- Max. 65536 of transfer cycles
- Interrupt function right after the transfer
- Selectable for address transfer increase/decrease by the software
- External transfer request input pin, external transfer request accept output pin, external transfer complete output pin three pins for each

### • Block Diagram

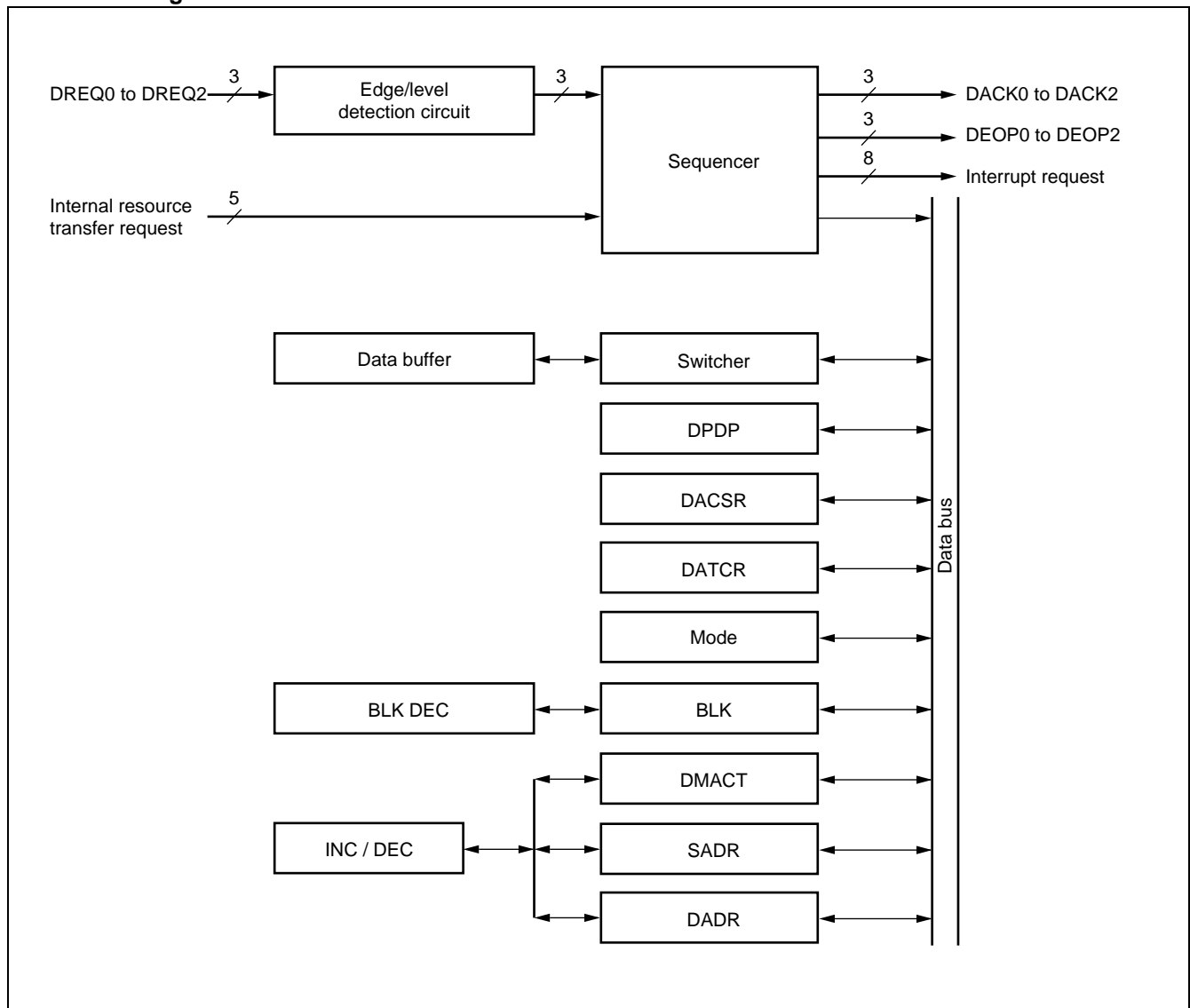

# MB91F155A/MB91155/MB91154

## • Registers (DMAC internal registers)

Address	bit 31	bit 16	bit 0	Initial value
00000200H	<div style="border: 1px solid black; padding: 5px; text-align: center;">DPDP</div>			XXXXXXXXB
00000201H				XXXXXXXXB
00000202H				XXXXXXXXB (R/W)
00000203H				X0000000B
00000204H	<div style="border: 1px solid black; padding: 5px; text-align: center;">DACSR</div>			00000000B
00000205H				00000000B
00000206H				00000000B (R/W)
00000207H				00000000B
00000208H	<div style="border: 1px solid black; padding: 5px; text-align: center;">DATCR</div>			XXXXXXXXB
00000209H				XXXX0000B (R/W)
0000020AH				XXXX0000B
0000020BH				XXXX0000B

( ) : Access  
 R/W : Read/Write enabled  
 X : Undefined

## • Register (DMA descriptor)

Address	bit 31	bit 0	
DPDP + 0H	<div style="border: 1px solid black; padding: 5px; text-align: center;">           -----            -----            -----         </div>		DMA ch0 Descriptor
DPDP + 0CH			DMA ch1 Descriptor
DPDP + 54H	<div style="border: 1px solid black; padding: 5px; text-align: center;">           -----            -----            -----         </div>		DMA ch7 Descriptor

# MB91F155A/MB91155/MB91154

## 3. UART

The UART is a serial I/O port for asynchronous (start and stop synchronization) communication or CLK synchronous communication. This product type contains this UART for four channels. Its features are as follows :

- Full-duplex double buffer
- Capable of asynchronous (start and stop synchronization) and CLK synchronous communication.
- Support for multiprocessor mode
- Baud rate by a dedicated baud rate generator
- Baud rate by an internal timer
  - The baud rate can be set with a 16-bit reload timer.
- Any baud rate can be set using an external clock.
- Error detection function (parity, framing, and overrun)
- NRZ-encoded transfer signals
- DMA transfer can be invoked by interrupt.

# MB91F155A/MB91155/MB91154

## • Block Diagram

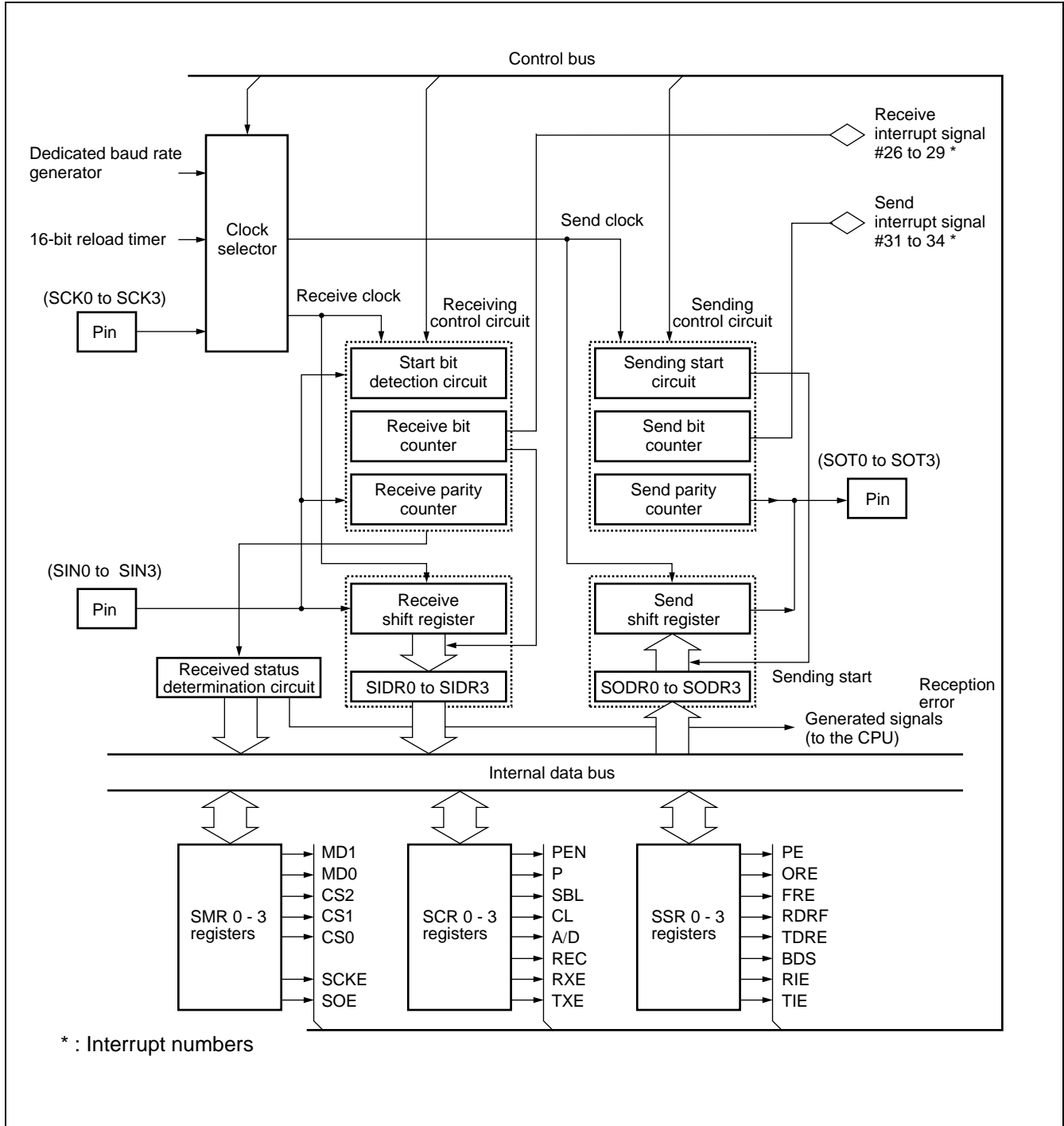

# MB91F155A/MB91155/MB91154

## • Register List

Address	bit 15	bit 8	bit 0	Initial value
0000001EH	SCR0			00000100B (R/W, W)
00000022H	SCR1			00000100B (R/W, W)
00000026H	SCR2			00000100B (R/W, W)
0000002AH	SCR3			00000100B (R/W, W)
0000001FH		SMR0		00000-00B (R/W)
00000023H		SMR1		00000-00B (R/W)
00000027H		SMR2		00000-00B (R/W)
0000002BH		SMR3		00000-00B (R/W)
0000001CH	SSR0			00001000B (R, R/W)
00000020H	SSR1			00001000B (R, R/W)
00000024H	SSR2			00001000B (R, R/W)
00000028H	SSR3			00001000B (R, R/W)
0000001DH		SIDR0/SODR0		XXXXXXXXXB (R, W)
00000021H		SIDR1/SIDR1		XXXXXXXXXB (R, W)
00000025H		SIDR2/SIDR2		XXXXXXXXXB (R, W)
00000029H		SIDR3/SIDR3		XXXXXXXXXB (R, W)

( ) : Access  
 R/W : Read/Write enabled  
 R : Read only  
 W : Write only  
 — : Not in use  
 X : Undefined

# MB91F155A/MB91155/MB91154

## 4. PPG Timer

The PPG timer can output highly accurate PWM waveforms efficiently.

This device contains six PPG timer channels and its features are as follows :

- Each channel consists of a 16-bit down counter, a 16-bit data register attached with a frequency setting buffer, a 16-bit compare register attached with a duty setting buffer, and a pin controller.
- The count clock for the 16-bit down counter can be selected from the following four types :  
Internal clocks  $\phi$ ,  $\phi/4$ ,  $\phi/16$ , and  $\phi/64$
- The counter value can be initialized by reset or counter borrow to "FFFFH."
- PWM output (by channel)
- DMA transfer can be invoked by interrupt.

### • Block Diagram (Entire configuration)

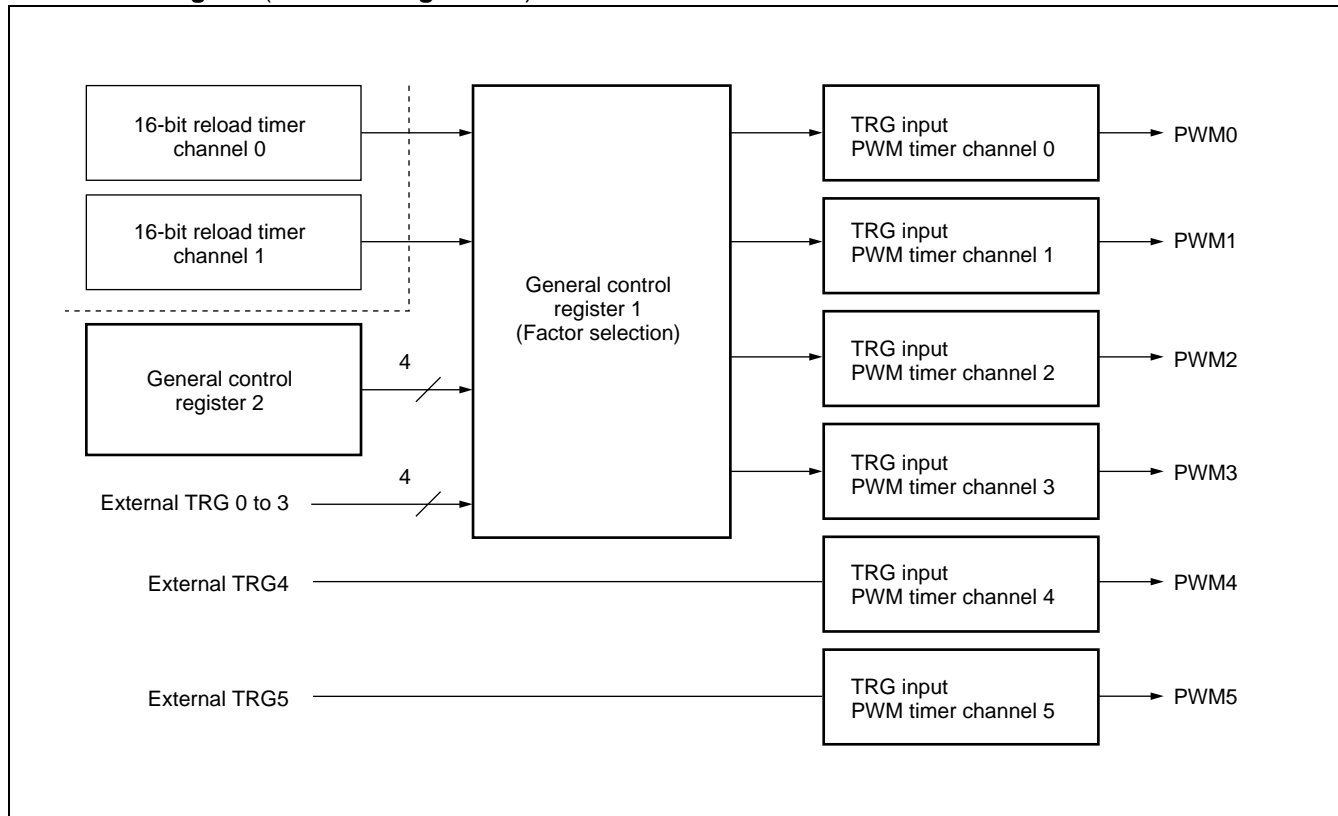



# MB91F155A/MB91155/MB91154

## • Block Diagram (for one channel)

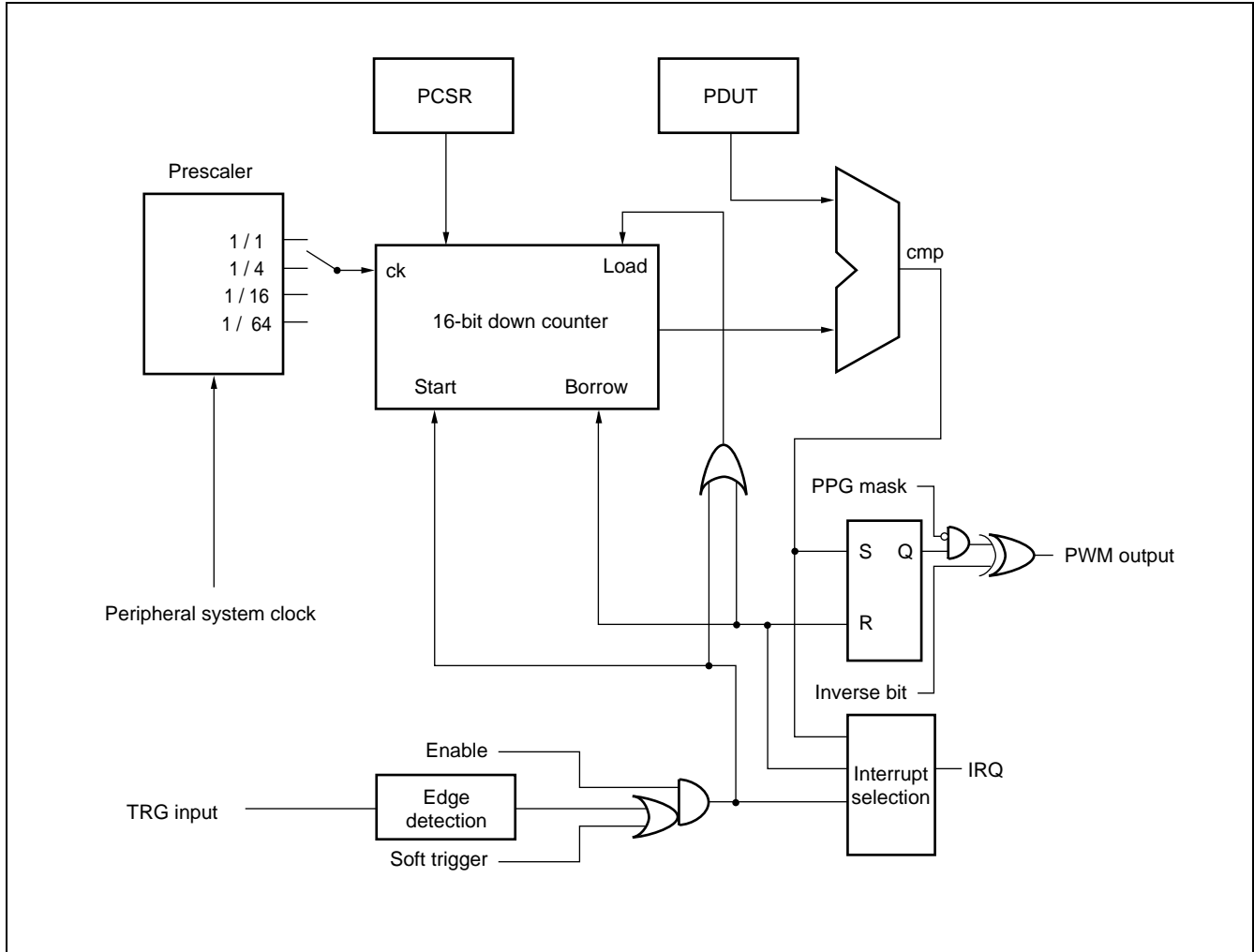

# MB91F155A/MB91155/MB91154

## • Register List

Address	bit 15	bit 8	bit 0	Initial value
00000094H 00000095H	GCN1			00110010 <sub>B</sub> (R/W) 00010000 <sub>B</sub> (R/W)
00000097H		GCN2		00000000 <sub>B</sub> (R/W)
00000098H 00000099H	PTMR0			11111111 <sub>B</sub> (R) 11111111 <sub>B</sub> (R)
0000009AH 0000009BH	PCSR0			XXXXXXXX <sub>B</sub> (W) XXXXXXXX <sub>B</sub> (W)
0000009CH 0000009DH	PDUT0			XXXXXXXX <sub>B</sub> (W) XXXXXXXX <sub>B</sub> (W)
0000009EH	PCNH0			0000000-B (R/W)
0000009FH		PCNL0		00000000 <sub>B</sub> (R/W)
000000A0H 000000A1H	PTMR1			11111111 <sub>B</sub> (R) 11111111 <sub>B</sub> (R)
000000A2H 000000A3H	PCSR1			XXXXXXXX <sub>B</sub> (W) XXXXXXXX <sub>B</sub> (W)
000000A4H 000000A5H	PDUT1			XXXXXXXX <sub>B</sub> (W) XXXXXXXX <sub>B</sub> (W)
000000A6H	PCNH1			0000000-B (R/W)
000000A7H		PCNL1		00000000 <sub>B</sub> (R/W)
000000A8H 000000A9H	PTMR2			11111111 <sub>B</sub> (R) 11111111 <sub>B</sub> (R)
000000AAH 000000ABH	PCSR2			XXXXXXXX <sub>B</sub> (W) XXXXXXXX <sub>B</sub> (W)
000000ACH 000000ADH	PDUT2			XXXXXXXX <sub>B</sub> (W) XXXXXXXX <sub>B</sub> (W)
000000AEH	PCNH2			0000000-B (R/W)
000000AFH		PCNL2		00000000 <sub>B</sub> (R/W)
000000B0H 000000B1H	PTMR3			11111111 <sub>B</sub> (R) 11111111 <sub>B</sub> (R)
000000B2H 000000B3H	PCSR3			XXXXXXXX <sub>B</sub> (W) XXXXXXXX <sub>B</sub> (W)
000000B4H 000000B5H	PDUT3			XXXXXXXX <sub>B</sub> (W) XXXXXXXX <sub>B</sub> (W)
000000B6H	PCNH3			0000000-B (R/W)
000000B7H		PCNL3		00000000 <sub>B</sub> (R/W)

( ) : Access R/W : Read/Write enabled R : Read only W : Write only — : Not in use X : Undefined

(Continued)

# MB91F155A/MB91155/MB91154

(Continued)

Address	bit 15	bit 8	bit 0	Initial value
000000B8H 000000B9H	PTMR4			11111111 <sub>B</sub> (R) 11111111 <sub>B</sub> (R)
000000BAH 000000BBH	PCSR4			XXXXXXXX <sub>B</sub> (W) XXXXXXXX <sub>B</sub> (W)
000000BCH 000000BDH	PDUT4			XXXXXXXX <sub>B</sub> (W) XXXXXXXX <sub>B</sub> (W)
000000BEH	PCNH4			0000000-B (R/W)
000000BFH		PCNL4		00000000 <sub>B</sub> (R/W)
000000C0H 000000C1H	PTMR5			11111111 <sub>B</sub> (R) 11111111 <sub>B</sub> (R)
000000C2H 000000C3H	PCSR5			XXXXXXXX <sub>B</sub> (W) XXXXXXXX <sub>B</sub> (W)
000000C4H 000000C5H	PDUT5			XXXXXXXX <sub>B</sub> (W) XXXXXXXX <sub>B</sub> (W)
000000C6H	PCNH5			0000000-B (R/W)
000000C7H		PCNL5		00000000 <sub>B</sub> (R/W)

( ) : Access                      R/W : Read/Write enabled  
 R : Read only                    W : Write only  
 — : Not in use                    X : Undefined

# MB91F155A/MB91155/MB91154

## 5. 16-bit Reload Timer

The 16-bit reload timer consists of a 16-bit down counter, a 16-bit reload register, a prescaler for creating internal count clocks, and a control register.

The input clock can be selected from three internal clock types (2/8/32 machine clock divisions).

DMA transfer can be invoked by interrupt.

This product type contains this 16-bit reload timer for four channels.

### • Block Diagram

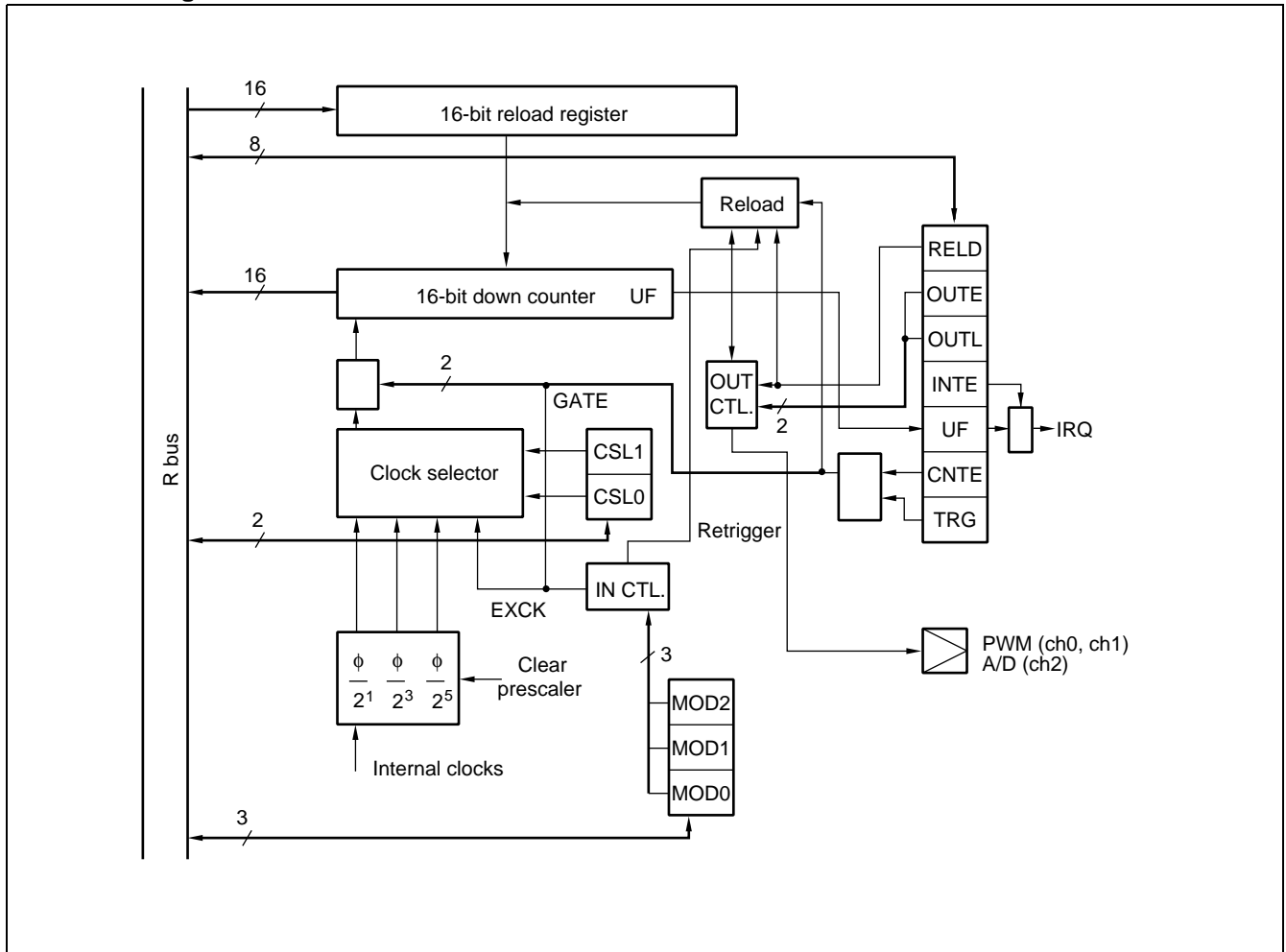

# MB91F155A/MB91155/MB91154

## • Register List

Address	bit 15	bit 0	Initial value
00000032H 00000033H	TMCSR0		----0000 <sub>B</sub> (R/W) 00000000 <sub>B</sub>
0000003AH 0000003BH	TMCSR1		----0000 <sub>B</sub> (R/W) 00000000 <sub>B</sub>
00000042H 00000043H	TMCSR2		----0000 <sub>B</sub> (R/W) 00000000 <sub>B</sub>
0000004AH 0000004BH	TMCSR3		----0000 <sub>B</sub> (R/W) 00000000 <sub>B</sub>
0000002EH 0000002FH	TMR0		XXXXXXXX <sub>B</sub> (R) XXXXXXXX <sub>B</sub>
00000036H 00000037H	TMR1		XXXXXXXX <sub>B</sub> (R) XXXXXXXX <sub>B</sub>
0000003EH 0000003FH	TMR2		XXXXXXXX <sub>B</sub> (R) XXXXXXXX <sub>B</sub>
00000046H 00000047H	TMR3		XXXXXXXX <sub>B</sub> (R) XXXXXXXX <sub>B</sub>
0000002CH 0000002DH	TMRLR0		XXXXXXXX <sub>B</sub> (W) XXXXXXXX <sub>B</sub>
00000034H 00000035H	TMRLR1		XXXXXXXX <sub>B</sub> (W) XXXXXXXX <sub>B</sub>
0000003CH 0000003DH	TMRLR2		XXXXXXXX <sub>B</sub> (W) XXXXXXXX <sub>B</sub>
00000044H 00000045H	TMRLR3		XXXXXXXX <sub>B</sub> (W) XXXXXXXX <sub>B</sub>

( ) : Access  
R/W : Read/Write enabled  
R : Read only  
W : Write only  
— : Not in use  
X : Undefined

# MB91F155A/MB91155/MB91154

## 6. Bit Search Module

The module searches data written to the input register for “0” or “1” or a “change” and returns the detected bit position.

### • Block Diagram

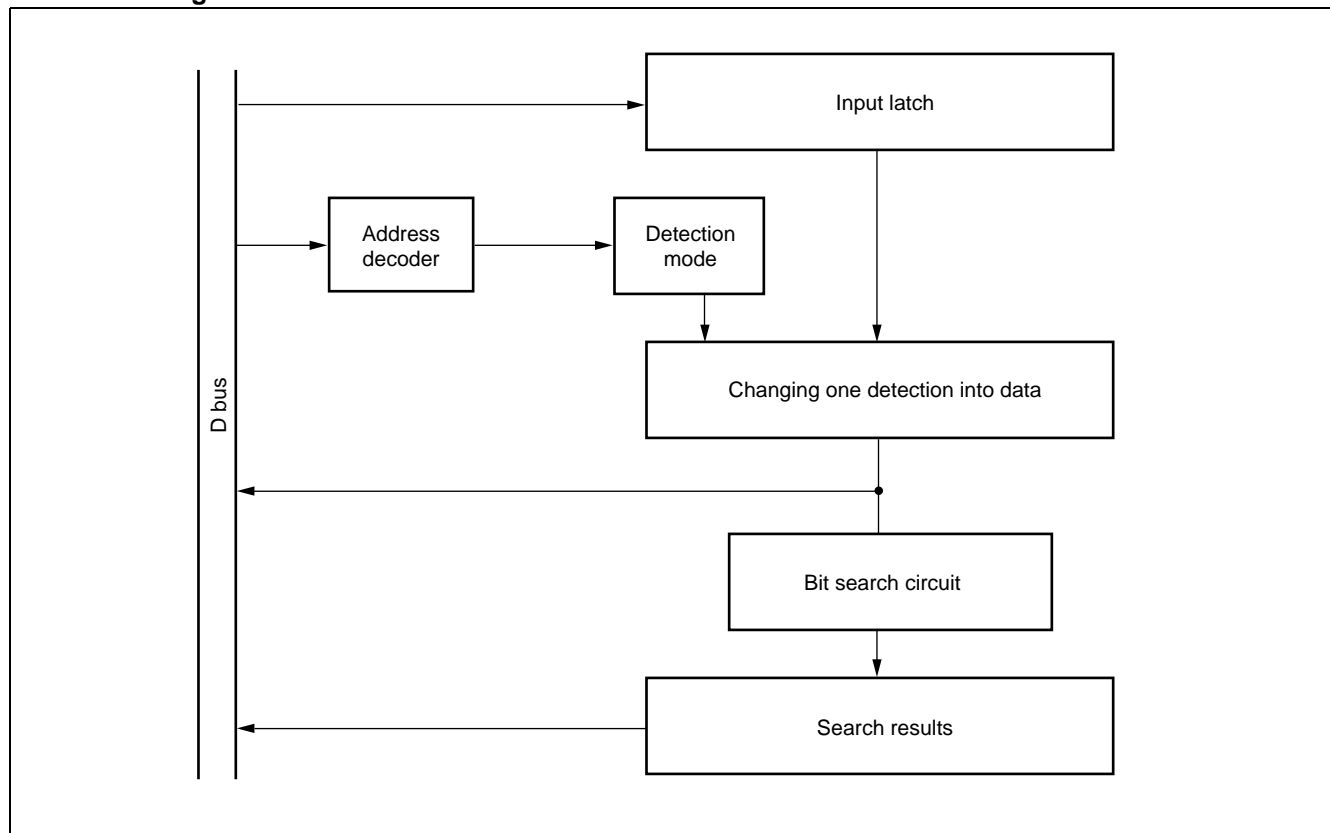

### • Register List

Address	bit 31	bit 16	bit 0	Initial value
000003F0H	<div style="border: 1px solid black; padding: 2px; text-align: center;">BSD0</div>			XXXXXXXXXB
000003F1H				XXXXXXXXXB
000003F2H				XXXXXXXXXB (W)
000003F3H				XXXXXXXXXB
000003F4H	<div style="border: 1px solid black; padding: 2px; text-align: center;">BSD1</div>			XXXXXXXXXB
000003F5H				XXXXXXXXXB
000003F6H				XXXXXXXXXB (R/W)
000003F7H				XXXXXXXXXB
000003F8H	<div style="border: 1px solid black; padding: 2px; text-align: center;">BSDC</div>			XXXXXXXXXB
000003F9H				XXXXXXXXXB
000003FAH				XXXXXXXXXB (W)
000003FBH				XXXXXXXXXB
000003FCH	<div style="border: 1px solid black; padding: 2px; text-align: center;">BSRR</div>			XXXXXXXXXB
000003FDH				XXXXXXXXXB
000003FEH				XXXXXXXXXB (R)
000003FFH				XXXXXXXXXB

( ) : Access      R/W : Read/Write enabled    R : Read only  
 W : Write only      X : Undefined

# MB91F155A/MB91155/MB91154

## 7. 8/10-bit A/D Converter (Sequential Conversion Type)

The A/D converter is a module that converts analog input voltage into a digital value. Its features are as follows :

- A minimum conversion time of 5.0  $\mu$ s/ch. (Including sampling time at a 33 MHz machine clock)
- Contains a sample and hold circuit.
- Resolution : 10 or 8 bits selectable.
- Selection of analog input from eight channels by program
  - Single conversion mode : Selects and converts one channel.
  - Continuous conversion mode : Converts a specified channel repeatedly.
  - Stop and convert mode : Stops after converting one channel and stands by until invoked the next time. (Conversion invoking can be synchronized.)
- DMA transfer can be invoked by interrupt.
- Selection of an invoking factor from software, external pin trigger (falling edge) , and 16-bit reload timer (rising edge) .

### • Block Diagram

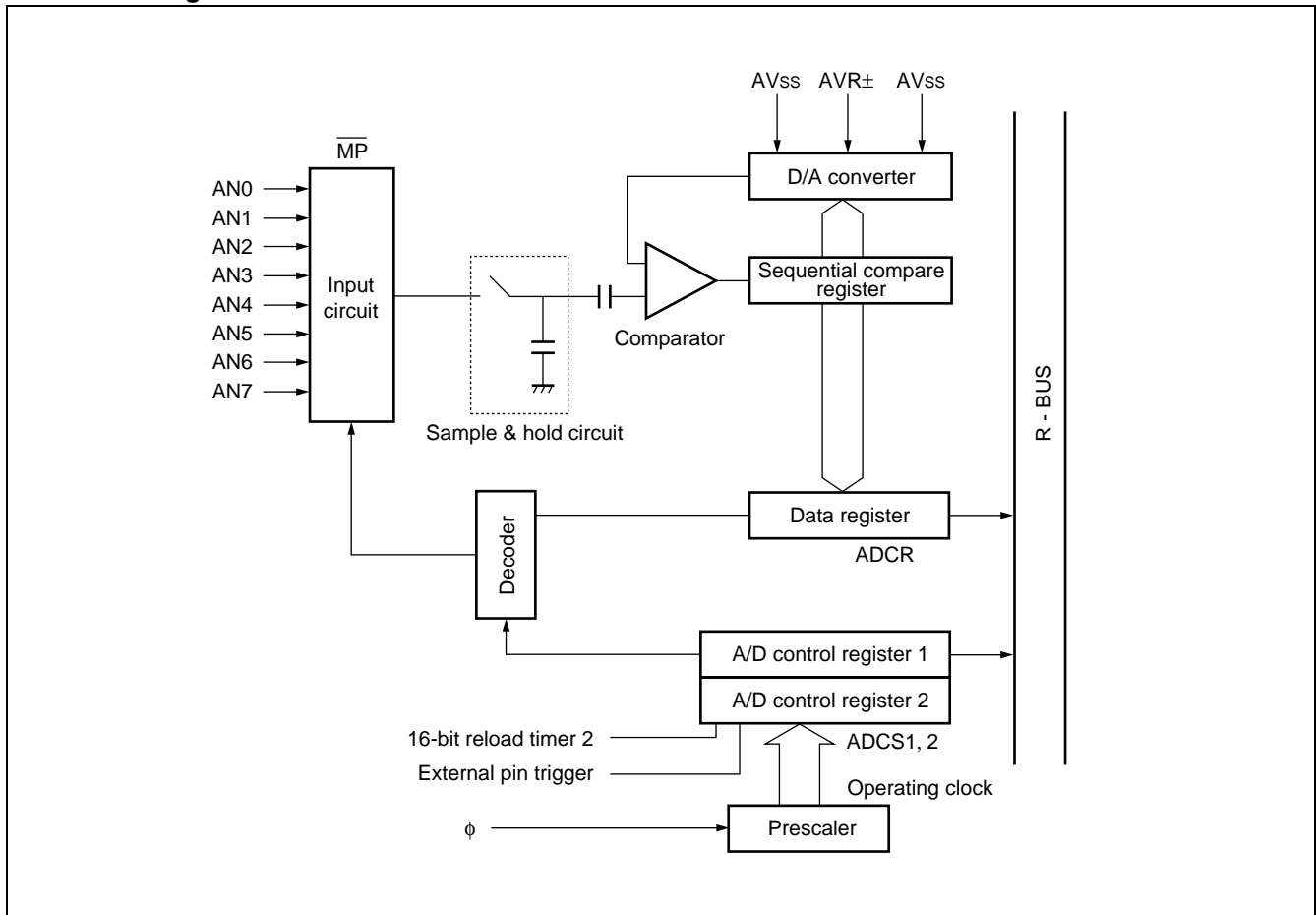

# MB91F155A/MB91155/MB91154

## • Register List

	bit 15	bit 0	
000000E4H	ADCR		00101-XXB (W, R)
000000E5H			XXXXXXXXB (R)
000000E6H	ADCS1		00000000B (R/W, W)
000000E7H		ADCS0	00000000B (R/W)
000000EBH		AICK	00000000B (R/W)

( ) : Access  
R/W : Read/Write enabled  
R : Read only  
W : Write only  
— : Not in use  
X : Undefined



# MB91F155A/MB91155/MB91154

## 8. Interrupt Controller

The interrupt controller accepts and arbitrates interrupts.

### • Block Diagram

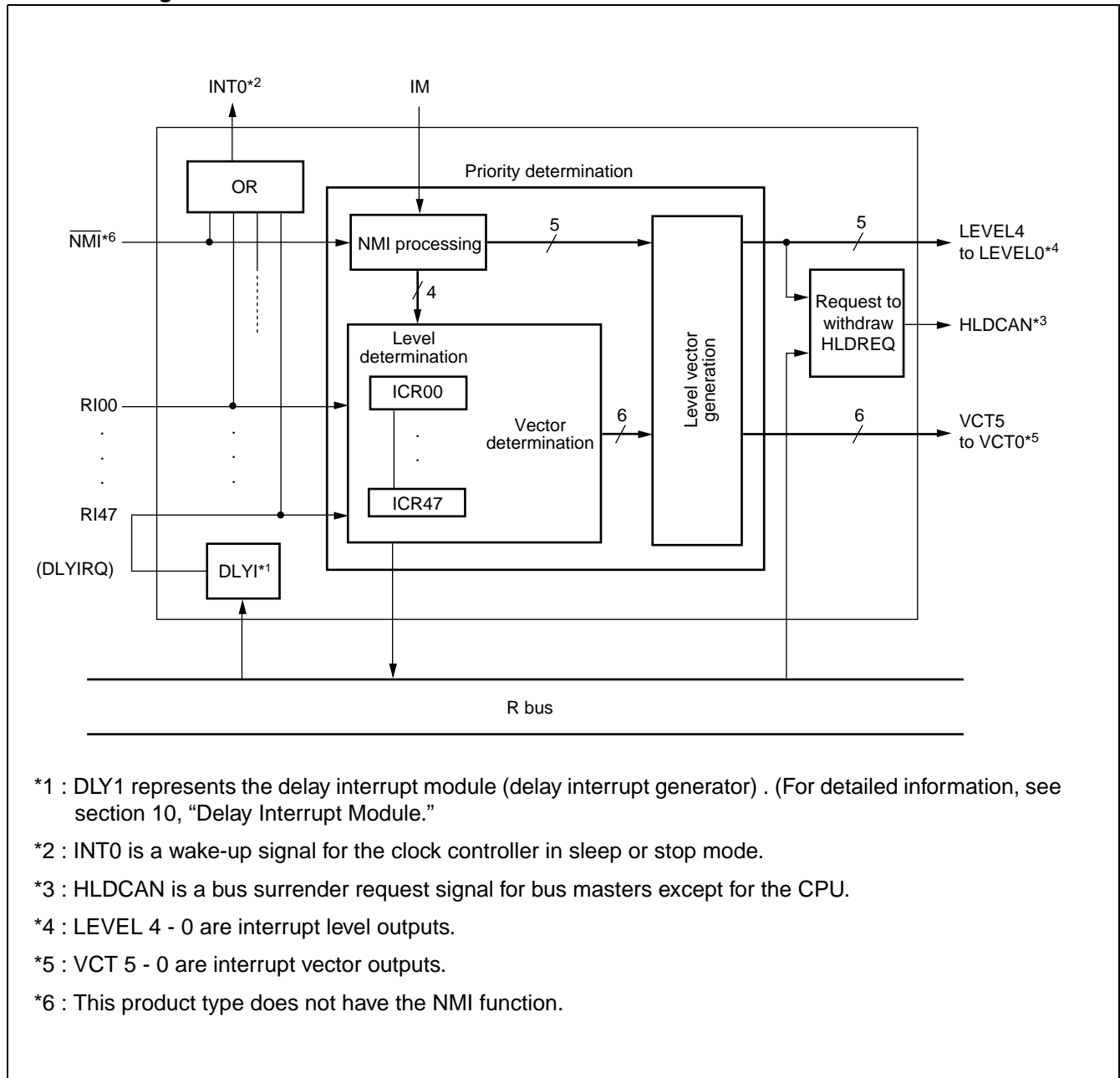

# MB91F155A/MB91155/MB91154

## • Register List

Address	bit 7	bit 0	Initial value	Address	bit 7	bit 0	Initial value
00000400H	ICR00		----1111B (R/W)	00000414H	ICR20		----1111B (R/W)
00000401H	ICR01		----1111B (R/W)	00000415H	ICR21		----1111B (R/W)
00000402H	ICR02		----1111B (R/W)	00000416H	ICR22		----1111B (R/W)
00000403H	ICR03		----1111B (R/W)	00000417H	ICR23		----1111B (R/W)
00000404H	ICR04		----1111B (R/W)	00000418H	ICR24		----1111B (R/W)
00000405H	ICR05		----1111B (R/W)	00000419H	ICR25		----1111B (R/W)
00000406H	ICR06		----1111B (R/W)	0000041AH	ICR26		----1111B (R/W)
00000407H	ICR07		----1111B (R/W)	0000041BH	ICR27		----1111B (R/W)
00000408H	ICR08		----1111B (R/W)	0000041CH	ICR28		----1111B (R/W)
00000409H	ICR09		----1111B (R/W)	0000041DH	ICR29		----1111B (R/W)
0000040AH	ICR10		----1111B (R/W)	0000041EH	ICR30		----1111B (R/W)
0000040BH	ICR11		----1111B (R/W)	0000041FH	ICR31		----1111B (R/W)
0000040CH	ICR12		----1111B (R/W)	00000420H	ICR32		----1111B (R/W)
0000040DH	ICR13		----1111B (R/W)	00000421H	ICR33		----1111B (R/W)
0000040EH	ICR14		----1111B (R/W)	00000422H	ICR34		----1111B (R/W)
0000040FH	ICR15		----1111B (R/W)	00000423H	ICR35		----1111B (R/W)
00000410H	ICR16		----1111B (R/W)	00000424H	ICR36		----1111B (R/W)
00000411H	ICR17		----1111B (R/W)	00000425H	ICR37		----1111B (R/W)
00000412H	ICR18		----1111B (R/W)	00000426H	ICR38		----1111B (R/W)
00000413H	ICR19		----1111B (R/W)	00000427H	ICR39		----1111B (R/W)

( ) : Access  
 R/W : Read/Write enabled  
 — : Not in use

(Continued)

# MB91F155A/MB91155/MB91154

(Continued)

Address	bit 7	bit 0	Initial value
00000428H	ICR40		---- 1 1 1 1 B (R/W)
00000429H	ICR41		---- 1 1 1 1 B (R/W)
0000042AH	ICR42		---- 1 1 1 1 B (R/W)
0000042BH	ICR43		---- 1 1 1 1 B (R/W)
0000042CH	ICR44		---- 1 1 1 1 B (R/W)
0000042DH	ICR45		---- 1 1 1 1 B (R/W)
0000042EH	ICR46		---- 1 1 1 1 B (R/W)
0000042FH	ICR47		---- 1 1 1 1 B (R/W)
00000431H	HRCL		---- 1 1 1 1 B (R/W)
00000430H	DICR		----- 0 B (R/W)

( ) : Access  
R/W : Read/Write enabled  
— : Not in use

# MB91F155A/MB91155/MB91154

## 9. External Interrupt

The external interrupt controller controls external interrupt requests input to INT pins 0 through 15. The level of requests to be detected can be selected from “H,” “L,” rising edge, and falling edge.

### • Block Diagram

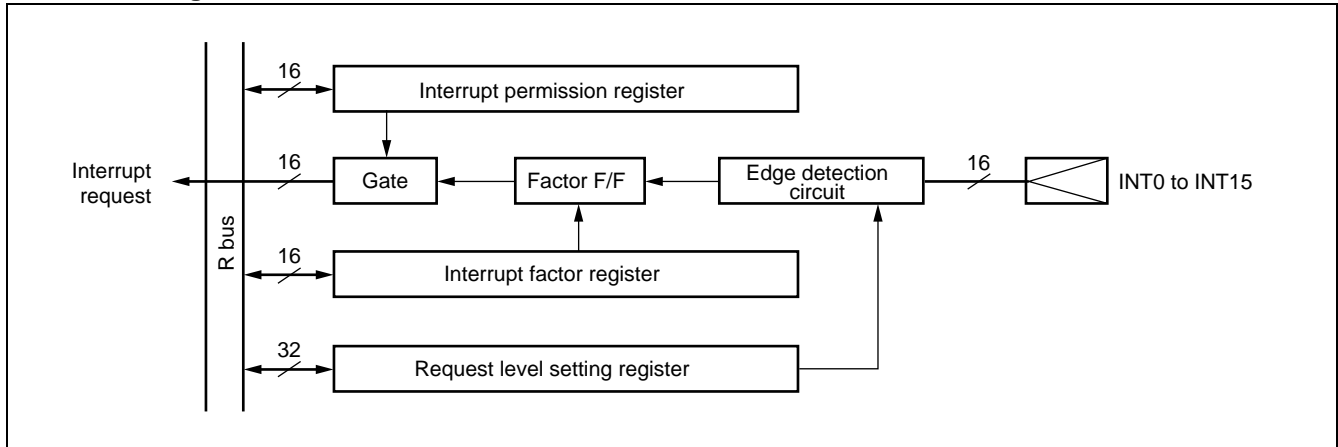

### • Register List

Address	bit 15	bit 8	bit 0	Initial value
000000C8H 000000C9H	EIRR0		ENIR0	00000000 <sub>B</sub> (R/W) 00000000 <sub>B</sub> (R/W)
000000CAH 000000CBH	EIRR1		ENIR1	00000000 <sub>B</sub> (R/W) 00000000 <sub>B</sub> (R/W)
000000CCH 000000CDH	ELVR0			00000000 <sub>B</sub> (R/W) 00000000 <sub>B</sub> (R/W)
000000CEH 000000CFH	ELVR1			00000000 <sub>B</sub> (R/W) 00000000 <sub>B</sub> (R/W)

( ) : Access  
R/W : Read/Write enabled

## 10. Delay Interrupt Module

The delay interrupt is a module that generates task switching interrupts. The use of this module allows the software to generate/cancel interrupt requests to the CPU.

For the block diagram of the delay interrupt module, see section 8, “Interrupt Controller.”

### • Register List

Address	bit 7	bit 0	Initial value
00000430H	DICR		----- 0 B (R/W)

( ) : Access  
R/W : Read/Write enabled  
— : Not in use

# MB91F155A/MB91155/MB91154

## 11. Clock Generator (Low power consumption mechanism)

The clock generator is responsible for the following functions :

- CPU clock generation (including the gear function)
- Peripheral clock generation (including the gear function)
- Reset generation and holding factors
- Standby function (including hardware standby)
- Contains PLL (multiplication circuit)

### • Block Diagram

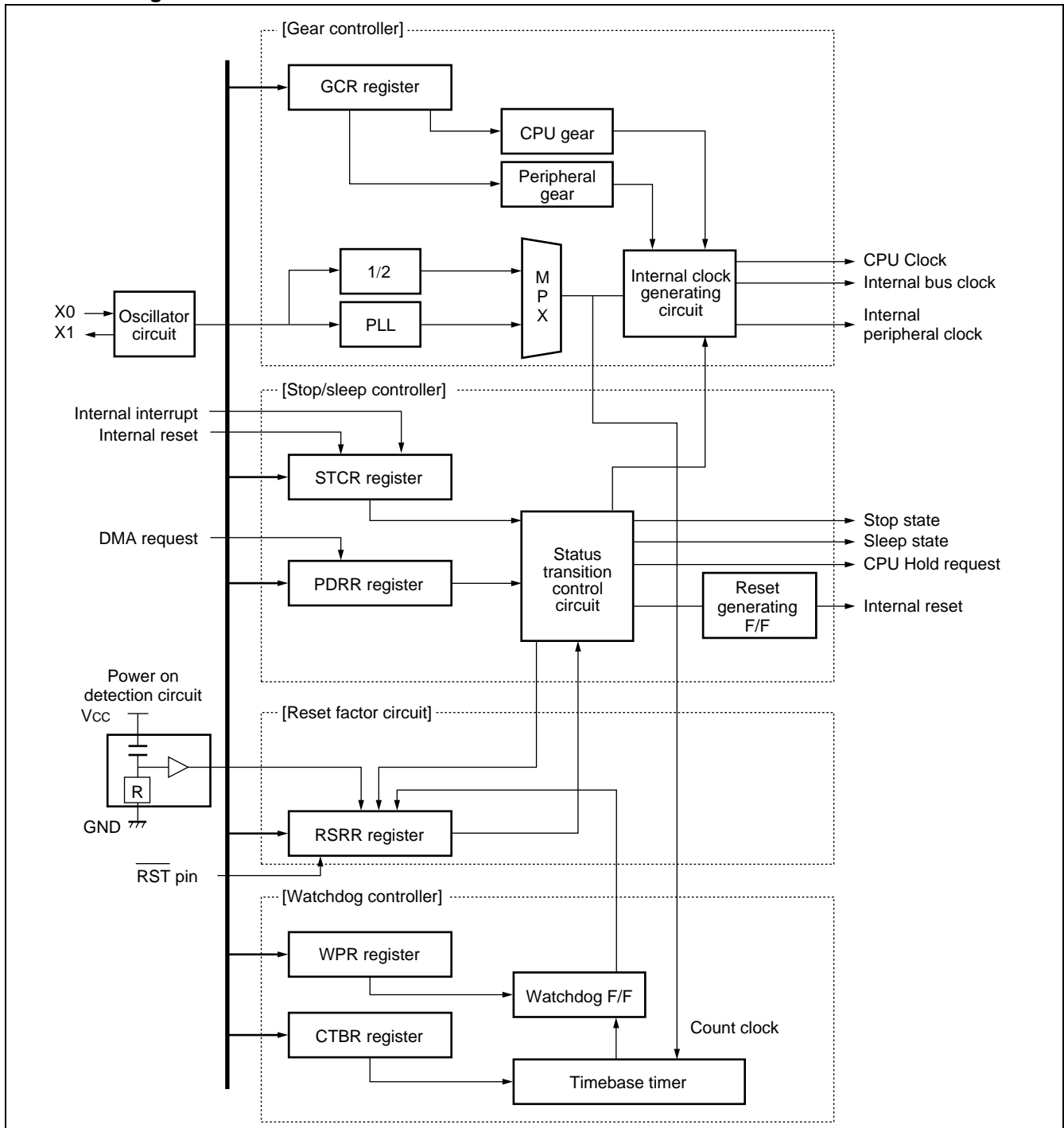

# MB91F155A/MB91155/MB91154

## • Register List

Address	bit 15	bit 8	bit 0	Initial value
00000480H	RSRR/WTCH			1-XXX-00B (R, W)
00000481H			STCR	000111--B (R/W, W)
00000482H	PDRR			---0000B (R/W)
00000483H			CTBR	XXXXXXXXXB (W)
00000484H	GCR			110011-1B (R/W, R)
00000485H			WPR	XXXXXXXXXB (W)

( ) : Access  
 R/W : Read/Write enabled  
 R : Read only  
 W : Write only  
 — : Not in use  
 X : Undefined

# MB91F155A/MB91155/MB91154

## 12. External Bus Interface

The external bus interface controls the interface between the external memory and the external I/O. Its features are as follows :

- 24-bit (16 MB) address output
- An 8/16-bit bus width can be set by chip select area.
- Inserts an automatic and programmable memory wait (for seven cycles at maximum) .
- Unused addresses/data pins are available as I/O ports.
- Support for little endian mode
- Use of a clock doubler, 33 MHz internal and 16.5 MHz external bus operations

### • Block Diagram

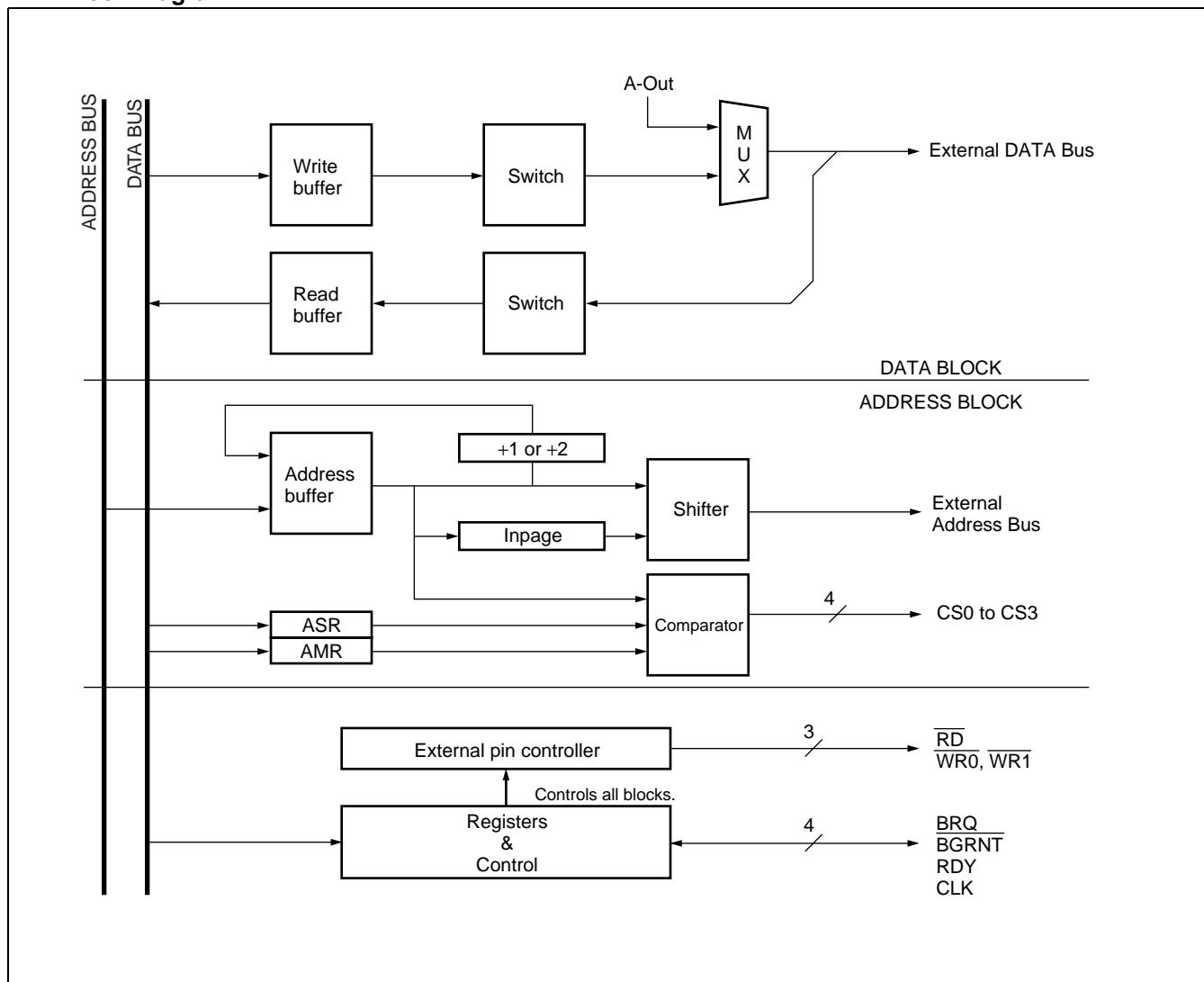

# MB91F155A/MB91155/MB91154

## • Register List

Address	bit 31	bit 16	bit 0	Initial value
0000060CH 0000060DH	ASR1			00000000 <sub>B</sub> (W) 00000001 <sub>B</sub> (W)
0000060EH 0000060FH		AMR1		00000000 <sub>B</sub> (W) 00000000 <sub>B</sub> (W)
00000610H 00000611H	ASR2			00000000 <sub>B</sub> (W) 00000010 <sub>B</sub> (W)
00000612H 00000613H		AMR2		00000000 <sub>B</sub> (W) 00000000 <sub>B</sub> (W)
00000614H 00000615H	ASR3			00000000 <sub>B</sub> (W) 00000011 <sub>B</sub> (W)
00000616H 00000617H		AMR3		00000000 <sub>B</sub> (W) 00000000 <sub>B</sub> (W)
00000618H 00000619H	ASR4			00000000 <sub>B</sub> (W) 00000100 <sub>B</sub> (W)
0000061AH 0000061BH		AMR4		00000000 <sub>B</sub> (W) 00000000 <sub>B</sub> (W)
0000061CH 0000061DH	ASR5			00000000 <sub>B</sub> (W) 00000101 <sub>B</sub> (W)
0000061EH 0000061FH		AMR5		00000000 <sub>B</sub> (W) 00000000 <sub>B</sub> (W)
00000620H	AMD0			---00111 <sub>B</sub> (R/W)
00000621H		AMD1		0--00000 <sub>B</sub> (R/W)
00000622H		AMD32		00000000 <sub>B</sub> (R/W)
00000623H			AMD4	0--00000 <sub>B</sub> (R/W)
00000624H	AMD5			0--00000 <sub>B</sub> (R/W)
00000628H 00000629H	EPCR0			----1100 <sub>B</sub> (W) -1111111 <sub>B</sub> (W)
0000062AH 0000062BH		EPCR1		----- <sub>B</sub> (W) 11111111 <sub>B</sub> (W)
000007FEH		LER		-----000 <sub>B</sub> (W)
000007FFH			MODR	XXXXXXXX <sub>B</sub> (W)

( ) : Access  
 R/W : Read/Write enabled  
 W : Write only  
 — : Not in use  
 X : Undefined



## 13. Multifunction Timer

The multifunction timer unit consists of one 16-bit free-run timer, eight 16-bit output compare registers, four 16-bit input capture registers, and six 16-bit PPG timer channels. By using this function waveforms can be output based on the 16-bit free-run timer and the input pulse width and external clock cycle can also be measured.

### • Timer Components

#### • 16-bit free-run timer ( × 1)

The 16-bit free-run timer consists of a 16-bit up counter, a control register, a 16-bit compare clear register, and a prescaler. The output value of this counter is used as the basic time (base timer) for output compare and input capture.

#### • Output compare ( × 8)

The output compare consists of eight 16-bit compare registers, a compare output latch, and a control register. When the 16-bit free-run timer value agrees to the compare register value, the output level can be inverted and an interrupt can also be generated.

#### • Input capture ( × 4)

The input capture consists of capture registers corresponding to four independent external input pins and a control register. By detecting any edge of signals input from external input pins, the 16-bit free-run timer value can be held in the capture register and an interrupt can be generated at the same time.

#### • 16-bit PPG timer ( × 6)

See the section on the PPG Timer.

# MB91F155A/MB91155/MB91154

## • Block Diagram

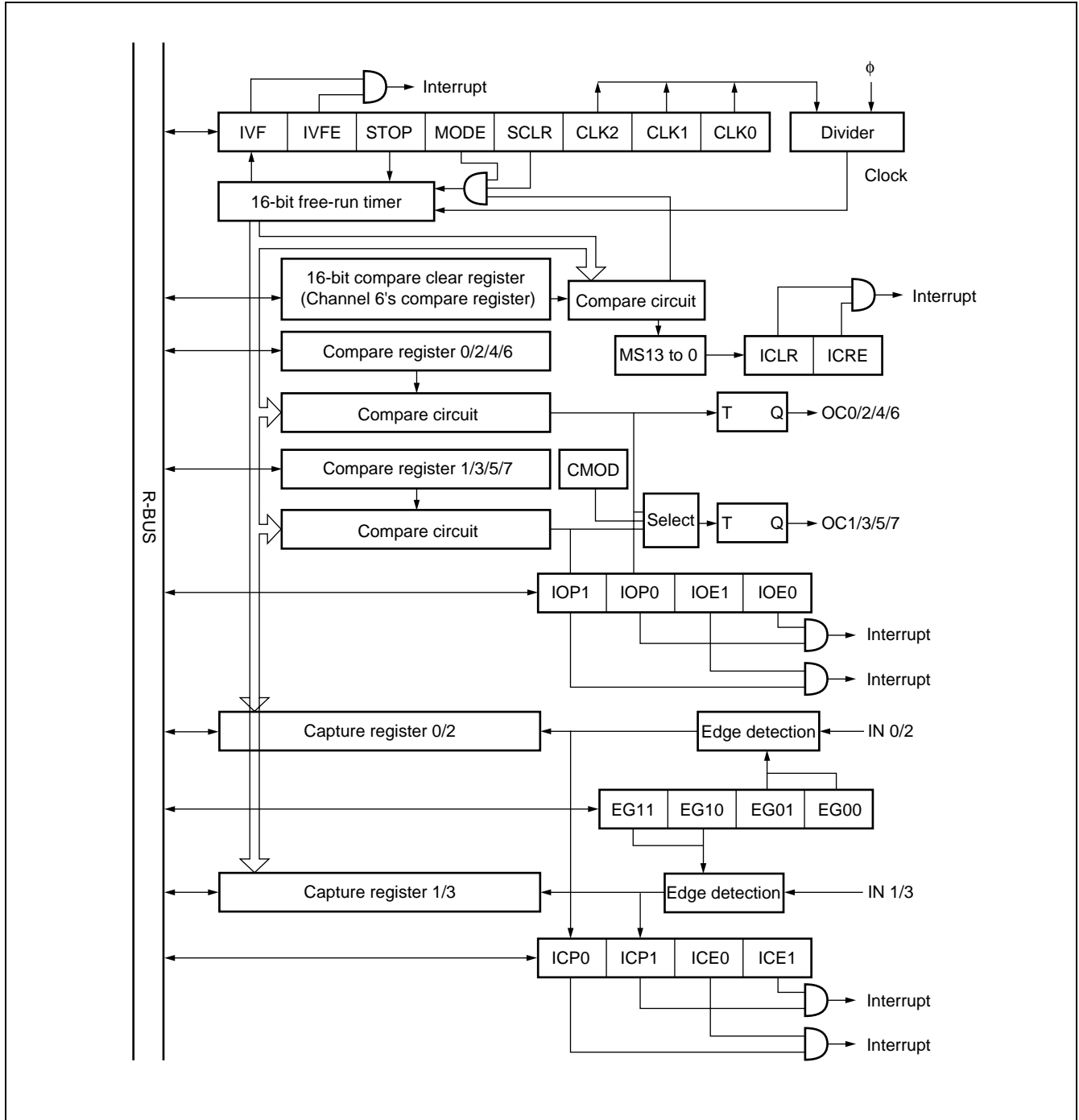

# MB91F155A/MB91155/MB91154

## • Register List

Address	bit15..... bit8 bit7 ..... bit0	Initial value
000068H 000069H	IPCP1	XXXXXXXXB ( R ) XXXXXXXXB ( R )
00006AH 00006BH	IPCP0	XXXXXXXXB ( R ) XXXXXXXXB ( R )
00006CH 00006DH	IPCP3	XXXXXXXXB ( R ) XXXXXXXXB ( R )
00006EH 00006FH	IPCP2	XXXXXXXXB ( R ) XXXXXXXXB ( R )
000071H	ICS23	0000000B ( R/W )
000073H	ICS01	0000000B ( R/W )
000074H 000075H	OCCP1	XXXXXXXXB ( R/W ) XXXXXXXXB ( R/W )
000076H 000077H	OCCP0	XXXXXXXXB ( R/W ) XXXXXXXXB ( R/W )
000078H 000079H	OCCP3	XXXXXXXXB ( R/W ) XXXXXXXXB ( R/W )
00007AH 00007BH	OCCP2	XXXXXXXXB ( R/W ) XXXXXXXXB ( R/W )
00007CH 00007DH	OCCP5	XXXXXXXXB ( R/W ) XXXXXXXXB ( R/W )
00007EH 00007FH	OCCP4	XXXXXXXXB ( R/W ) XXXXXXXXB ( R/W )
000080H 000081H	OCCP7	XXXXXXXXB ( R/W ) XXXXXXXXB ( R/W )
000082H 000083H	OCCP6	XXXXXXXXB ( R/W ) XXXXXXXXB ( R/W )
000084H 000085H	OCS3,2	XXX0000B ( R/W ) 0000XX00B ( R/W )
000086H 000087H	OCS1,0	XXX0000B ( R/W ) 0000XX00B ( R/W )
000088H 000089H	OCS7,6	XXX0000B ( R/W ) 0000XX00B ( R/W )
00008AH 00008BH	OCS5,4	XXX0000B ( R/W ) 0000XX00B ( R/W )
00008CH 00008DH	TCDT	0000000B ( R/W ) 0000000B ( R/W )
00008EH 00008FH	TCCS	0 - - - - - B ( R/W ) 0000000B ( R/W )

( ) : Access R/W : Read/Write enabled R : Read only — : Not in use X : Undefined

# MB91F155A/MB91155/MB91154

## 14. Calendar Macro

This macro is a calendar macro with a basic clock of 32.768 kHz.

The macro accomplishes clock functions including, year, month, date, hour, minutes, seconds, day of the week, and leap years.

The macro counts the last two digits of calendar years 0 through 99.

### • Block Diagram

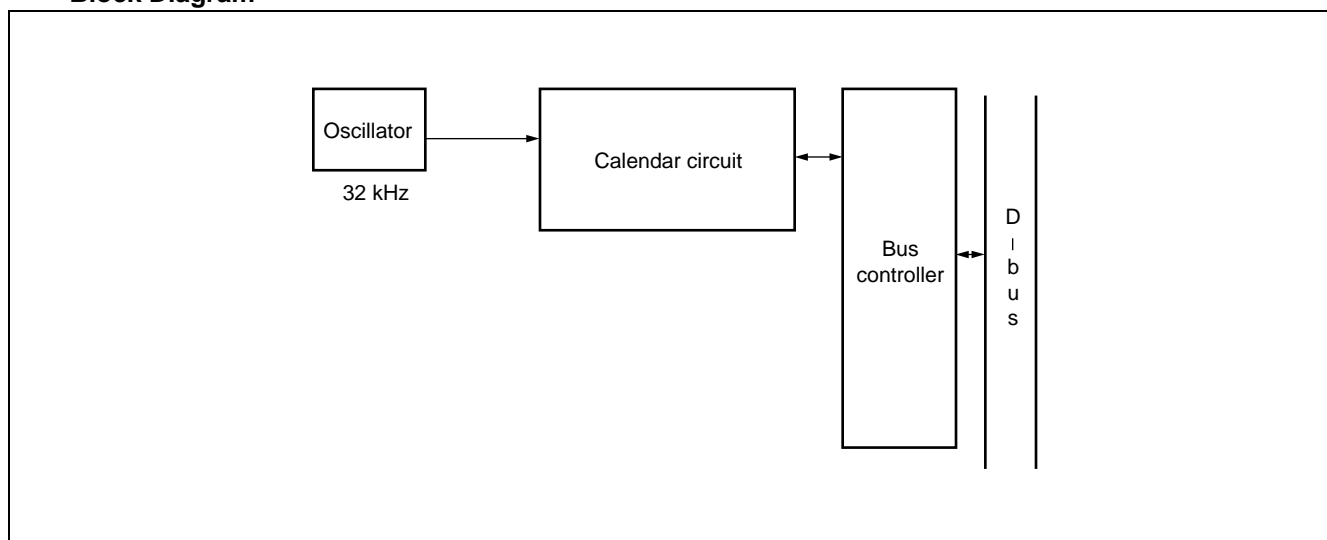

### • Register List

Address	bit15 .....	bit8	bit17 .....	bit0	Initial value
000210H	CAC		CA1		0000000B ( R/W )
000211H					-- XXXXXXB ( R/W )
000212H	CA2		CA3		-- XXXXXXB ( R/W )
000213H					--- XXXXXXB ( R/W )
000214H	CA4		CA5		--- XXXXXXB ( R/W )
000215H					----- XXXB ( R/W )
000216H	CA6		CA7		---- XXXXB ( R/W )
000217H					-XXXXXXXXB ( R/W )
00021FH			CAS		0-----0B ( R/W )

( ) : Access  
 R/W : Read/Write enabled  
 — : Not in use  
 X : Undefined

# MB91F155A/MB91155/MB91154

## 15. I<sup>2</sup>C Interface

The I<sup>2</sup>C interface is a serial I/O port that supports the Inter IC BUS and operates as a master/slave device on the I<sup>2</sup>C bus.

### • Features of the I<sup>2</sup>C Interface

Contains one I<sup>2</sup>C interface channel.

The interface has the following features :

- Master/slave send and receive
- Arbitration function
- Clock synchronization function
- Slave address/general call address detection function
- Transfer direction detection function
- Repeated generation and detection of start conditions
- Bus error detection function

### • Register List

#### • Bus control register (IBCR)

Address	bit 15	bit 14	bit 13	bit 12	bit 11	bit 10	bit 9	bit 8	Initial value
0000-0120 <sub>H</sub>	BER	BEIE	SCC	MSS	ACK	GCAA	INTE	INT	00000000 <sub>B</sub>
	R/W	R/W	R/W	R/W	R/W	R/W	R/W	R/W	

#### • Bus status register (IBSR)

Address	bit 7	bit 6	bit 5	bit 4	bit 3	bit 2	bit 1	bit 0	Initial value
0000-0121 <sub>H</sub>	BB	RSC	AL	LRB	$\overline{TR}$	AAS	GCA	FBT	00000000 <sub>B</sub>
	R	R	R	R	R	R	R	R	

#### • Address register (IADR)

Address	bit 15	bit 14	bit 13	bit 12	bit 11	bit 10	bit 9	bit 8	Initial value
0000-0122 <sub>H</sub>	—	A6	A5	A4	A3	A2	A1	A0	- XXXXXXX <sub>B</sub>
	—	R/W	R/W	R/W	R/W	R/W	R/W	R/W	

#### • Clock control register (ICCR)

Address	bit 7	bit 6	bit 5	bit 4	bit 3	bit 2	bit 1	bit 0	Initial value
0000-0123 <sub>H</sub>	—	—	EN	CS4	CS3	CS2	CS1	CS0	-- 0XXXX <sub>B</sub>
	—	—	R/W	R/W	R/W	R/W	R/W	R/W	

#### • Data register (IDAR)

Address	bit 7	bit 6	bit 5	bit 4	bit 3	bit 2	bit 1	bit 0	Initial value
0000-0125 <sub>H</sub>	D7	D6	D5	D4	D3	D2	D1	D0	XXXXXXXX <sub>B</sub>
	R/W	R/W	R/W	R/W	R/W	R/W	R/W	R/W	

R/W : Read/Write enabled, R : Read only, — : Not in use, X : Undefined

# MB91F155A/MB91155/MB91154

## • Block Diagram

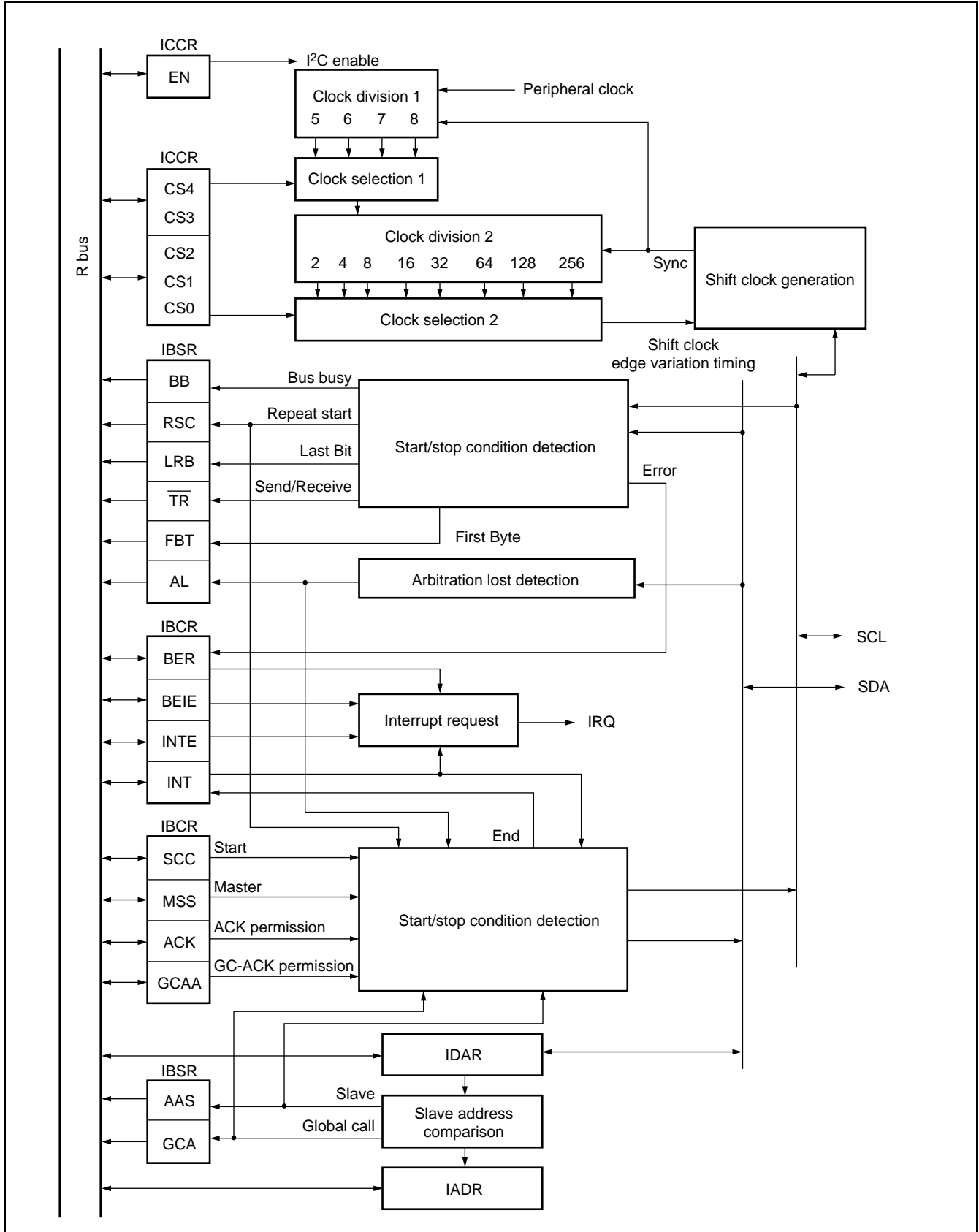

# MB91F155A/MB91155/MB91154

## 16. FLASH Memory

The MB91F155A contains a 510-Kbyte (4 Mbits) flash memory. The sectors can be erased all at once or sector by sector and that can be written with the FR-CPU by half word (16 bits) using a single 0.3 V power supply.

The MB91F155 accomplishes the following functions by a combination of the flash memory macro and the FR-CPU interface circuit :

- Functions as the CPU program/data storage memory :
  - When used as a ROM, the memory is accessible with a 32-bit bus width.
  - Allows the CPU to read from/write to/erase the memory (automatic program algorithm\*).
- Functions equivalent to the stand-alone MBM29LV400C flash memory product :
  - Allows a ROM programmer to read from/write to/erase the memory (automatic program algorithm\*)

At this time, using the flash memory from the FR-CPU is described. For detailed information about using the flash memory from the ROM programmer, refer to the ROM programmer instruction manual.

\* : Automatic program algorithm = Embedded Algorithm™  
Embedded Algorithm™ is a trademark of Advanced Micro Devices, Inc.

### • Block Diagram

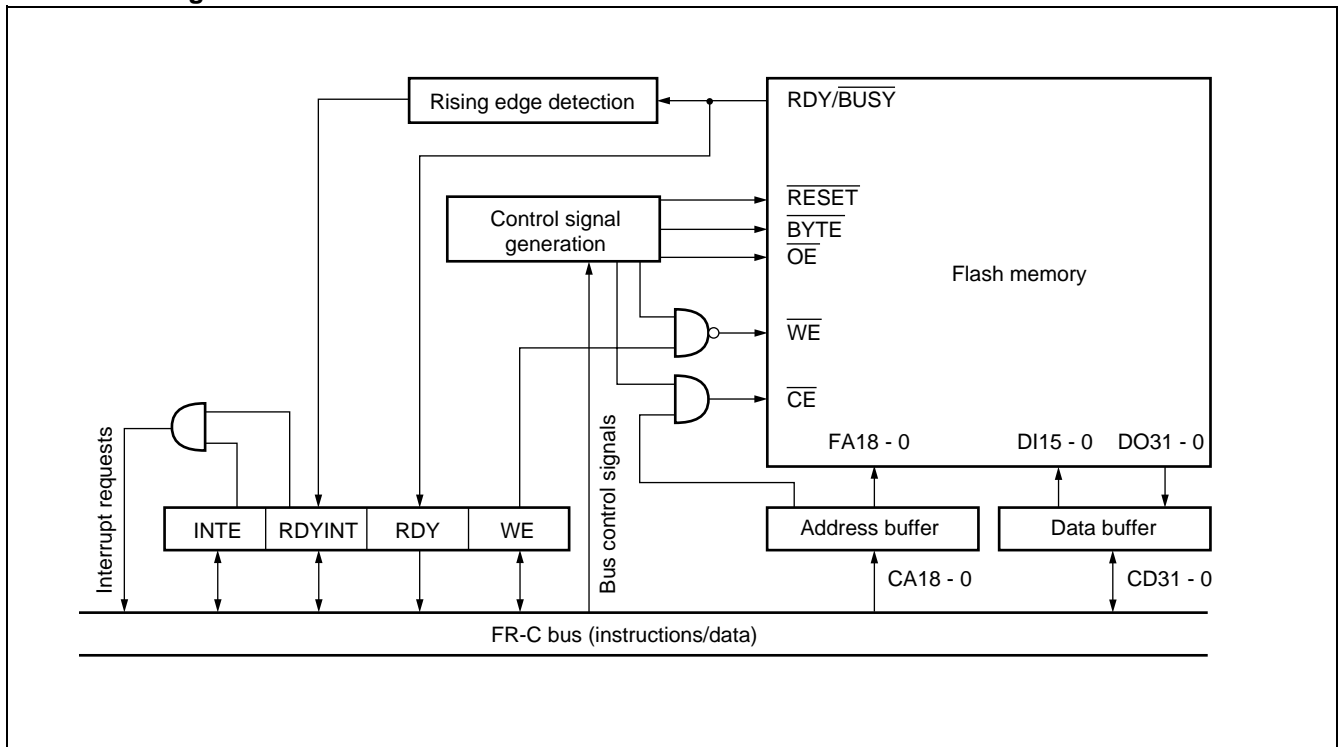

# MB91F155A/MB91155/MB91154

## • Memory Map

Flash memory address mapping varies between FLASH memory mode and CPU mode. Mapping in each mode is shown next.

### Memory mapping in FLASH memory mode of MB91F155A :

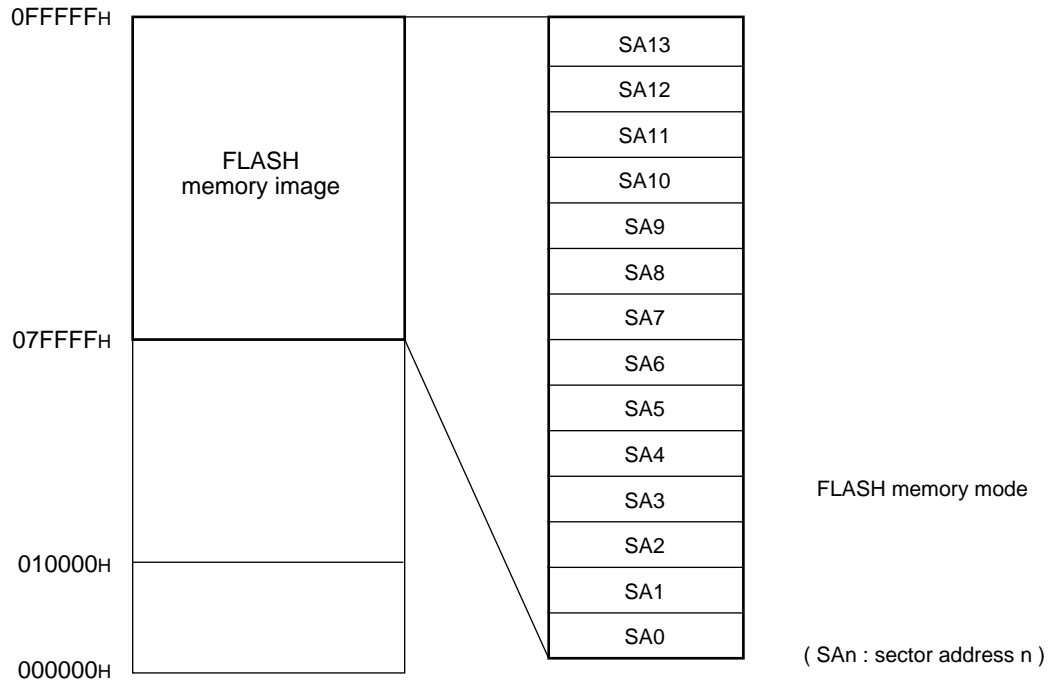

### Memory mapping in CPU mode of MB91F155A :

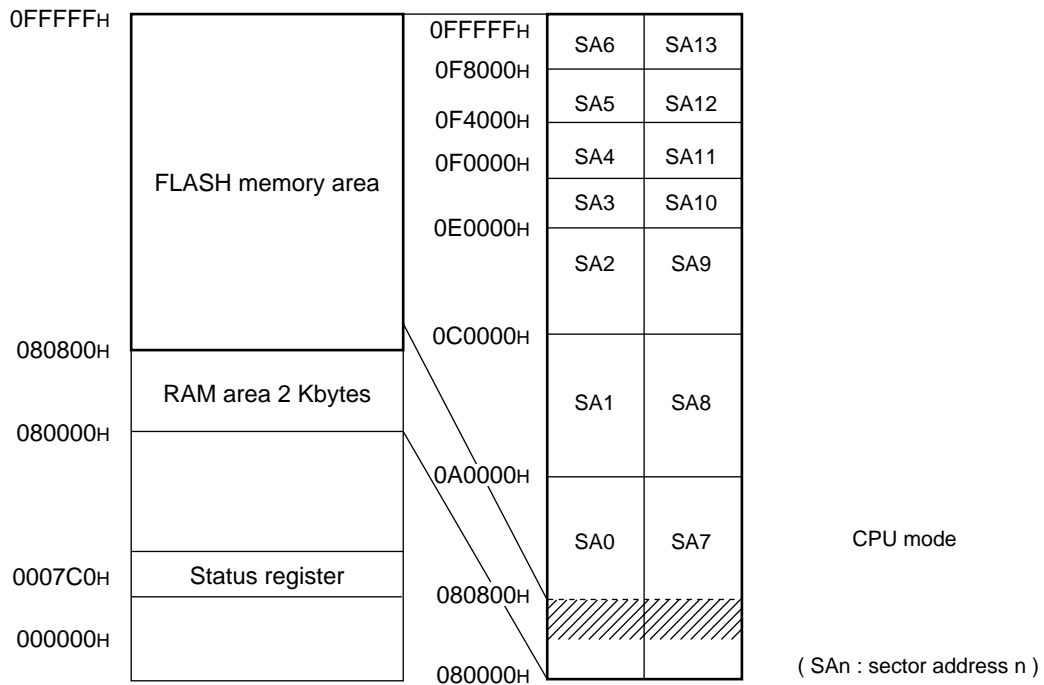



# MB91F155A/MB91155/MB91154

## • Sector Address Table

Sector address	Address range	Corresponding bit positions	Sector capacity
SA7	080802, 3 <sub>H</sub> to 09FFFE, F <sub>H</sub> (16 bits on LSB side)	bit15 to 0	64 Kbyte
SA8	0A0002, 3 <sub>H</sub> to 0BFFFE, F <sub>H</sub> (16 bits on LSB side)	bit15 to 0	64 Kbyte
SA9	0C0002, 3 <sub>H</sub> to 0DFFFE, F <sub>H</sub> (16 bits on LSB side)	bit15 to 0	64 Kbyte
SA10	0E0002, 3 <sub>H</sub> to 0EFFFFE, F <sub>H</sub> (16 bits on LSB side)	bit15 to 0	32 Kbyte
SA11	0F0002, 3 <sub>H</sub> to 0F3FFE, F <sub>H</sub> (16 bits on LSB side)	bit15 to 0	8 Kbyte
SA12	0F4002, 3 <sub>H</sub> to 0F7FFE, F <sub>H</sub> (16 bits on LSB side)	bit15 to 0	8 Kbyte
SA13	0F8002, 3 <sub>H</sub> to 0FFFFE, F <sub>H</sub> (16 bits on LSB side)	bit15 to 0	16 Kbyte
SA0	080800, 1 <sub>H</sub> to 09FFFC, D <sub>H</sub> (16 bits on MSB side)	bit31 to 16	64 Kbyte
SA1	0A0000, 1 <sub>H</sub> to 0BFFFC, D <sub>H</sub> (16 bits on MSB side)	bit31 to 16	64 Kbyte
SA2	0C0000, 1 <sub>H</sub> to 0DFFFC, D <sub>H</sub> (16 bits on MSB side)	bit31 to 16	64 Kbyte
SA3	0E0000, 1 <sub>H</sub> to 0EFFFFC, D <sub>H</sub> (16 bits on MSB side)	bit31 to 16	32 Kbyte
SA4	0F0000, 1 <sub>H</sub> to 0F3FFC, D <sub>H</sub> (16 bits on MSB side)	bit31 to 16	8 Kbyte
SA5	0F4000, 1 <sub>H</sub> to 0F7FFC, D <sub>H</sub> (16 bits on MSB side)	bit31 to 16	8 Kbyte
SA6	0F8000, 1 <sub>H</sub> to 0FFFFC, D <sub>H</sub> (16 bits on MSB side)	bit31 to 16	16 Kbyte

## • Registers

### FLCR : Status register (CPU mode)

This register indicates the FLASH memory operating status. The register controls interrupts to the CPU as well as writing to the FLASH memory.

This register is accessible only in CPU mode. Do not access this register with read modify write instructions.

	bit 7	bit 6	bit 5	bit 4	bit 3	bit 2	bit 1	bit 0
0007C0H	INTE	RDYINT	WE	RDY	—	—	—	LPM
	R/W (0)	R/W (0)	R/W (0)	R (X)	— (X)	— (X)	— (X)	R/W (0)

R/W : Read/Write enabled, R : Read only, — : Not in use, X : Undefined

### FWTC : Wait register

This register controls waiting for the FLASH memory in CPU mode.

The register also controls accessing to read from the FLASH memory (33 MHz operations) at high speeds.

	bit 7	bit 6	bit 5	bit 4	bit 3	bit 2	bit 1	bit 0
0007C4H	—	—	—	—	—	FACH	WTC1	WTC0
	— (—)	— (—)	— (—)	— (—)	— (—)	W (0)	R/W (0)	R/W (0)

R/W : Read/Write enabled, W : Write only, — : Not in use, X : Undefined

# MB91F155A/MB91155/MB91154

## 17. 8-bit D/A Converter

This block is of an 8-bit resolution, R-2R D/A converter. The block contains three D/A converter channels and each D/A control register can control output independently. The D/A converter pin is a dedicated pin.

### • Block Diagram

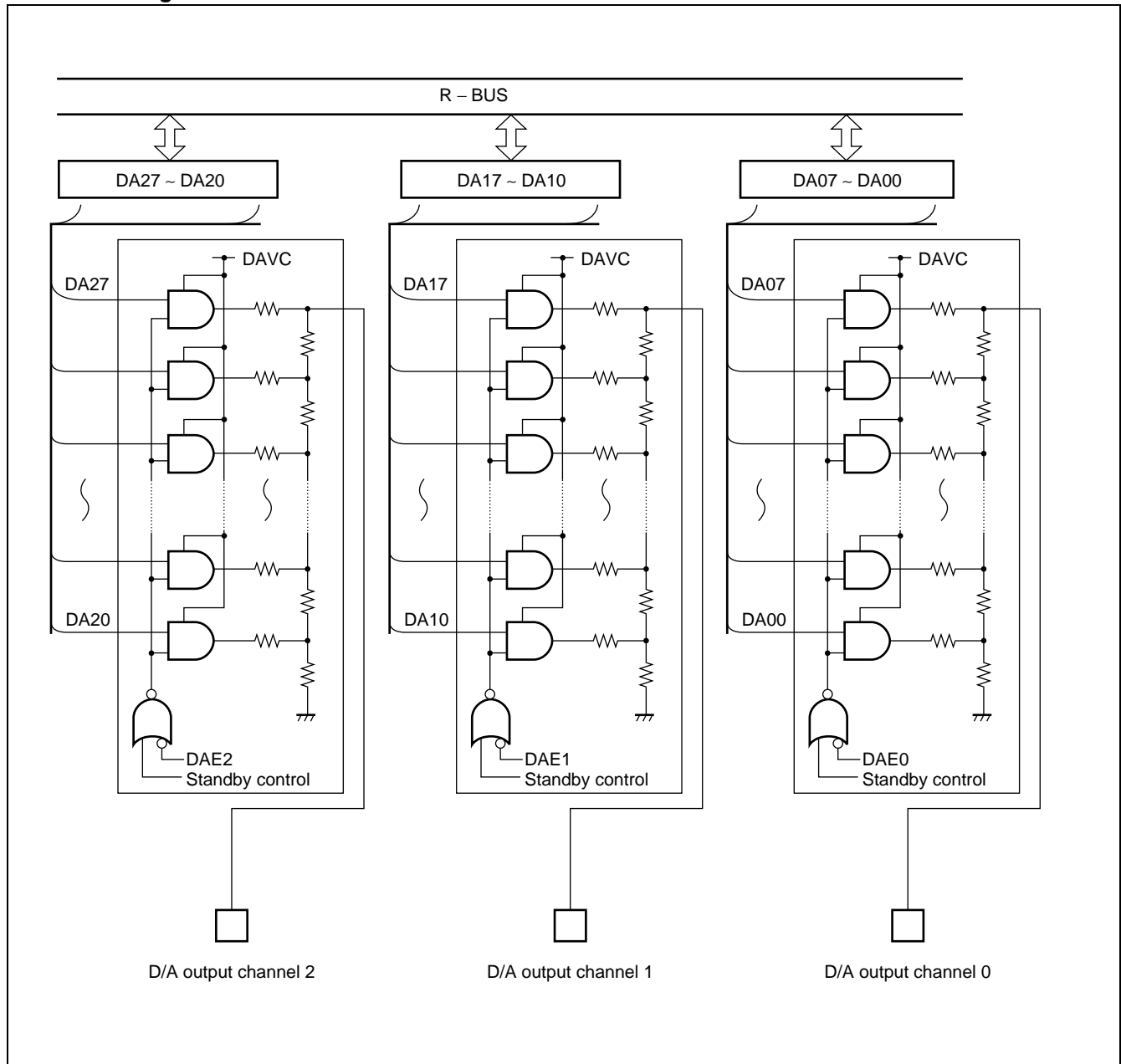

# MB91F155A/MB91155/MB91154

## • Register List

DADR0 00000E3H	bit	7	6	5	4	3	2	1	0	Initial value
		DA07	DA06	DA05	DA04	DA03	DA02	DA01	DA00	XXXXXXXXB ( R/W )
DADR1 00000E2H	bit	15	14	13	12	11	10	9	8	Initial value
		DA17	DA16	DA15	DA14	DA13	DA12	DA11	DA10	XXXXXXXXB ( R/W )
DADR2 00000E1H	bit	23	22	21	20	19	18	17	16	Initial value
		DA27	DA26	DA25	DA24	DA23	DA22	DA21	DA20	XXXXXXXXB ( R/W )
DACR0 00000DFH	bit	7	6	5	4	3	2	1	0	Initial value
		—	—	—	—	—	—	—	DAE0	-----0B ( R/W )
DACR1 00000DEH	bit	15	14	13	12	11	10	9	8	Initial value
		—	—	—	—	—	—	—	DAE1	-----0B ( R/W )
DACR2 00000DDH	bit	23	22	21	20	19	18	17	16	Initial value
		—	—	—	—	—	—	—	DAE2	-----0B ( R/W )

( ) : Access, R/W : Read/Write enabled, — : Not in use, X : Undefined

# MB91F155A/MB91155/MB91154

## 18. 8/16-bit Up/Down Counters/Timers

This is the up/down counter/timer block consisting of six event input pins, two 8-bit up/down counters, two 8-bit reload/compare registers, and their control circuits.

The features of this module are as follows :

- Capable of counting in the (0) d- (256) d range by the 8-bit count register.  
(In 16-bit  $\times$  1 operating mode, the register can count in the (0) d- (65535) d range.)
- Four count modes to choose from by the count clock.
- In timer mode the count clock can be selected from two internal clock types.
- In up/down count mode an external pin input signal detection edge can be selected.
- The phase-difference count mode is suitable for encoder counting, such as of motors. Rotation angles, rotating speeds, and so on can be counted accurately and easily by inputting the output of phases A, B, and Z.
- Two types of function to choose from for the ZIN pin. (Enabled in all modes)
- Equipped with compare and reload functions which can be used individually or in combination. When combined, these functions can count up/down at any width.
- The immediately preceding count direction can be identified by the count direction flag.
- Capable of individually controlling interrupt generation when comparison results match, at occurrence of reload (underflow) or overflow, or when the count direction changes.

# MB91F155A/MB91155/MB91154

## • Block Diagram

### • 8/16-bit Up/Down Counter/Timer (channel 0)

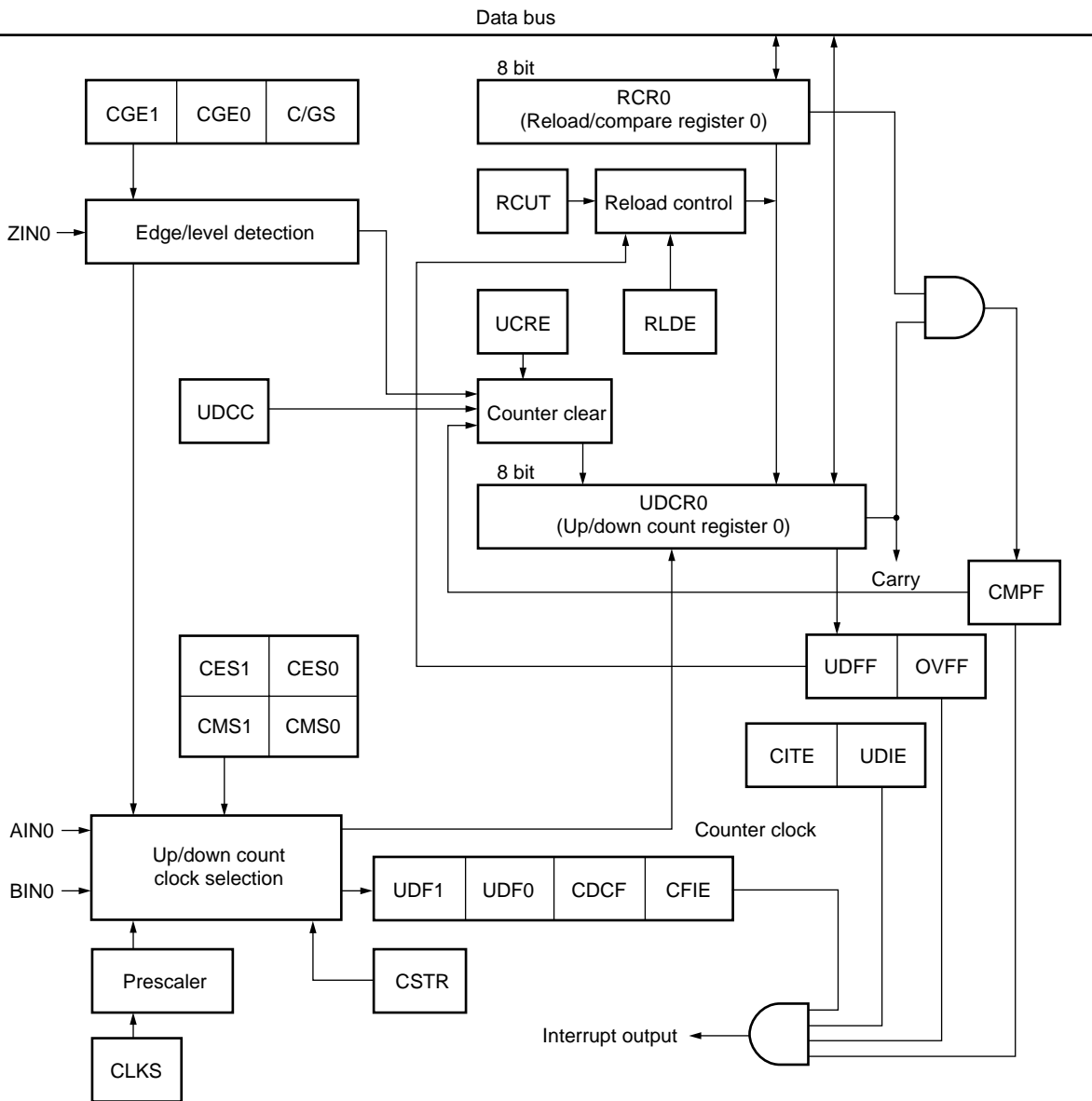

# MB91F155A/MB91155/MB91154

- 8/16-bit Up/Down Counter/Timer (channel 1)

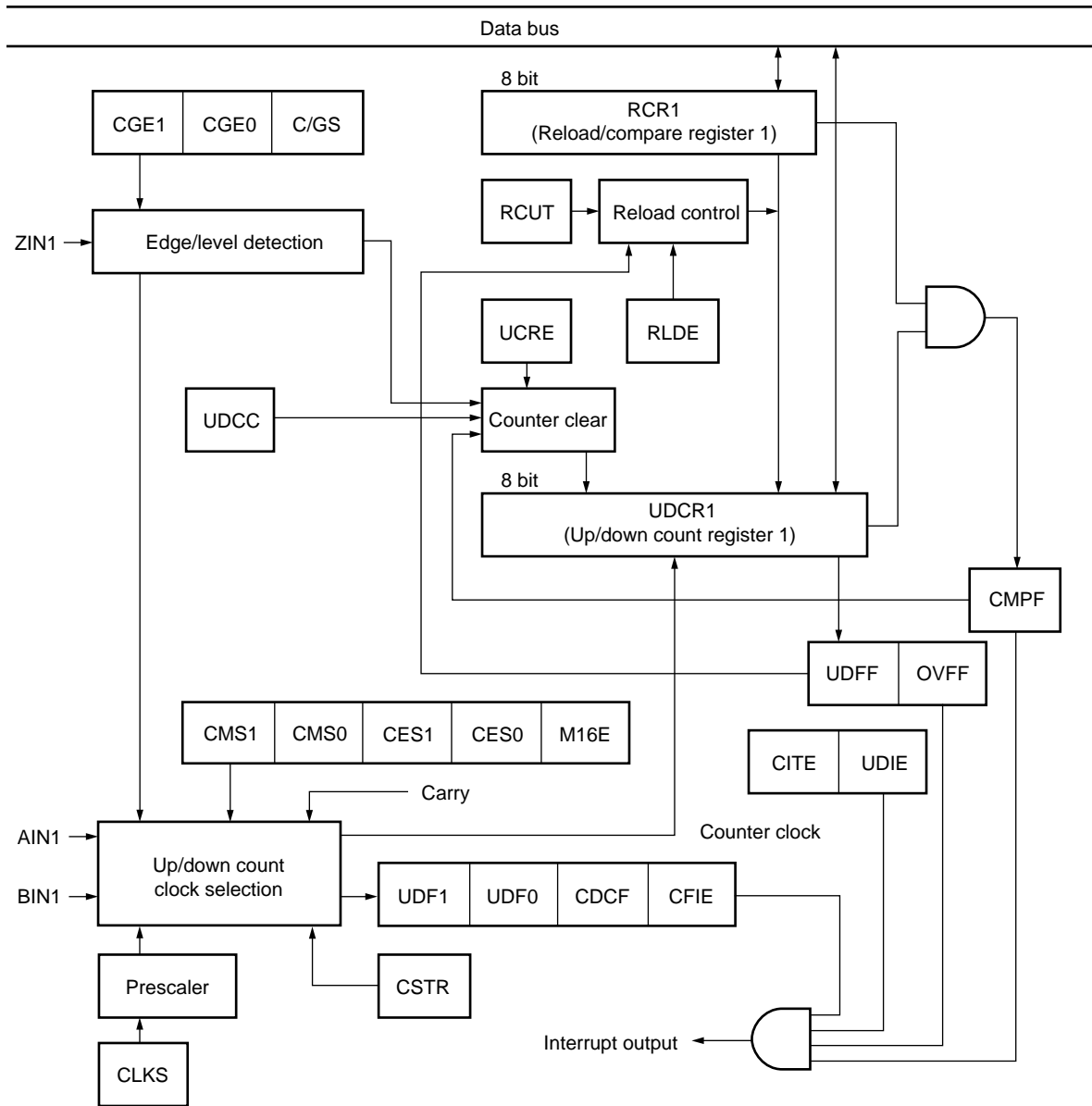

# MB91F155A/MB91155/MB91154

## • Register List

Address : 00005FH	bit	7	6	5	4	3	2	1	0	Initial value	
		UDCR0								0000000B	(R)
Address : 00005EH	bit	15	14	13	12	11	10	9	8	Initial value	
		UDCR1								0000000B	(R)
Address : 00005DH	bit	7	6	5	4	3	2	1	0	Initial value	
		RCR0								0000000B	(W)
Address : 00005CH	bit	15	14	13	12	11	10	9	8	Initial value	
		RCR1								0000000B	(W)
Address : 000063H	bit	7	6	5	4	3	2	1	0	Initial value	
		CSR0								0000000B	(R/W)
Address : 000067H	bit	7	6	5	4	3	2	1	0	Initial value	
		CSR1								0000000B	(R/W)
Address : 000061H	bit	7	6	5	4	3	2	1	0	Initial value	
		CCRL0								-000X000B	(R/W, W)
Address : 000065H	bit	7	6	5	4	3	2	1	0	Initial value	
		CCRL1								-000X000B	(R/W, W)
Address : 000060H	bit	15	14	13	12	11	10	9	8	Initial value	
		CCRH0								0000000B	(R/W)
Address : 000064H	bit	15	14	13	12	11	10	9	8	Initial value	
		CCRH1								-0000000B	(R/W)

( ) : Access, R/W : Read/Write enabled, R : Read only, W : Write only, — : Not in use, X : Undefined

# MB91F155A/MB91155/MB91154

## 19. Peripheral STOP Control

This function can be used to stop the clock of unused resources in order to conserve more power.

### • Register List

Address	bit7 ..... bit0	Initial value
000090H	STPR0	0000 - - - B ( R/W )
000091H	STPR1	00000000B ( R/W )
000092H	STPR2	000000 - - B ( R/W )

( ) : Access, R/W : Read/Write enabled, — : Not in use



# MB91F155A/MB91155/MB91154

## ■ ELECTRICAL CHARACTERISTICS

### 1. Absolute Maximum Ratings

( $V_{SS} = AV_{SS} = 0.0\text{ V}$ )

Parameter	Symbol	Value		Unit	Remarks
		Min	Max		
Power supply voltage	$V_{CC}$	$V_{SS} - 0.3$	$V_{SS} + 3.6$	V	
Analog supply voltage	$AV_{CC}$	$V_{SS} - 0.3$	$V_{SS} + 3.6$	V	*1
Analog reference voltage	$AV_{RH}$	$V_{SS} - 0.3$	$V_{SS} + 3.6$	V	*1
Input voltage	$V_I$	$V_{SS} - 0.3$	$V_{CC} + 0.3$	V	
Input voltage (open drain port J)	$V_{I2}$	$V_{SS} - 0.3$	$V_{SS} + 5.5$	V	
Analog pin input voltage	$V_{IA}$	$V_{SS} - 0.3$	$AV_{CC} + 0.3$	V	
Output voltage	$V_O$	$V_{SS} - 0.3$	$V_{CC} + 0.3$	V	
"L" level maximum output current	$I_{OL}$	—	10	mA	*2
"L" level average output current	$I_{OLAV}$	—	4	mA	*3
"L" level total maximum output current	$\Sigma I_{OL}$	—	100	mA	
"L" level total average output current	$\Sigma I_{OLAV}$	—	50	mA	*4
"H" level maximum output current	$I_{OH}$	—	-10	mA	*2
"H" level average output current	$I_{OHAV}$	—	-4	mA	*3
"H" level total maximum output current	$\Sigma I_{OH}$	—	-50	mA	
"H" level total average output current	$\Sigma I_{OHAV}$	—	-20	mA	*4
Power consumption	$P_D$	—	500	mW	
Operating temperature	$T_A$	0	+70	°C	
Storage temperature	$T_{stg}$	-55	+150	°C	

\*1 : Take care not to exceed  $V_{CC} + 0.3\text{ V}$  when turning on the power, for example.

Take care also to prevent  $AV_{CC}$  from exceeding  $V_{CC}$  when turning on the power, for example.

\*2 : The maximum output current stipulates the peak value of a single concerned pin.

\*3 : The average output current stipulates the average current flowing through a single concerned pin over a period of 100 ms.

\*4 : The total average output current stipulates the average current flowing through all concerned pins over a period of 100 ms.

WARNING: Semiconductor devices can be permanently damaged by application of stress (voltage, current, temperature, etc.) in excess of absolute maximum ratings. Do not exceed these ratings.

# MB91F155A/MB91155/MB91154

## 2. Recommended Operating Conditions

( $V_{SS} = AV_{SS} = 0.0\text{ V}$ )

Parameter	Symbol	Value		Unit	Remarks
		Min	Max		
Power supply voltage	$V_{CC}$	3.15	3.6	V	During normal operations.
		2.0	3.6		The RAM state is retained when stopped.
Analog supply voltage	$AV_{CC}$	$V_{SS} + 3.15$	$V_{SS} + 3.6$	V	
Analog reference voltage (High potential side)	AVRH	$AV_{CC} - 0.3$	$AV_{CC}$	V	
Analog reference voltage (Low potential side)	AVRL	$AV_{SS}$	$AV_{SS} + 0.3$	V	
Operating temperature	$T_A$	0	+70	°C	

**WARNING:** The recommended operating conditions are required in order to ensure the normal operation of the semiconductor device. All of the device's electrical characteristics are warranted when the device is operated within these ranges.

Always use semiconductor devices within their recommended operating condition ranges. Operation outside these ranges may adversely affect reliability and could result in device failure.

No warranty is made with respect to uses, operating conditions, or combinations not represented on the data sheet. Users considering application outside the listed conditions are advised to contact their FUJITSU representatives beforehand.

# MB91F155A/MB91155/MB91154

## 3. DC Characteristics

(V<sub>CC</sub> = 3.15 V to 3.6 V, V<sub>SS</sub> = AV<sub>SS</sub> = 0 V, T<sub>A</sub> = 0 °C to +70 °C)

Parameter	Symbol	Pin name	Condition	Value			Unit	Remarks
				Min	Typ	Max		
“H” level input voltage	V <sub>IH</sub>	Input except for hysteresis input pin*	—	0.65 × V <sub>CC</sub>	—	V <sub>CC</sub> + 0.3	V	
	V <sub>IHS</sub>	Hysteresis input pin*	—	0.8 × V <sub>CC</sub>	—	V <sub>CC</sub> + 0.3	V	
“L” level input voltage	V <sub>IL</sub>	Input except for hysteresis input pin*	—	V <sub>SS</sub> - 0.3	—	0.25 × V <sub>CC</sub>	V	
	V <sub>ILS</sub>	Hysteresis input pin*	—	V <sub>SS</sub> - 0.3	—	0.2 × V <sub>CC</sub>	V	
“H” level output voltage	V <sub>OH</sub>	Except for port J.	V <sub>CC</sub> = 3.15 V I <sub>OH</sub> = 4.0 mA	V <sub>CC</sub> - 0.5	—	—	V	
“L” level output voltage	V <sub>OL</sub>	Except for port J.	V <sub>CC</sub> = 3.15 V I <sub>OL</sub> = 4.0 mA	—	—	0.4	V	
Input leakage current	I <sub>LI</sub>	—	V <sub>CC</sub> = 3.6 V, V <sub>SS</sub> < V <sub>I</sub> < V <sub>CC</sub>	—	—	±5	μA	
“L” level output voltage	V <sub>OL2</sub>	Port J	V <sub>CC</sub> = 3.15 V I <sub>OL</sub> = 15 mA	—	—	0.4	V	Open drain
Output application voltage	V <sub>D</sub>	Port J	—	V <sub>CC</sub> - 0.3	—	V <sub>SS</sub> + 5.0	V	Open drain
Pullup resistance	R <sub>PULL</sub>	$\overline{\text{RST}}$ , pullup pin	—	—	50	—	kΩ	
Power supply current	I <sub>CC</sub>	V <sub>CC</sub>	V <sub>CC</sub> = 3.3 V, 33 MHz	—	85	120	mA	External buss access available
	I <sub>CCS</sub>	V <sub>CC</sub>	V <sub>CC</sub> = 3.3 V, 33 MHz	—	60	100	mA	During sleep mode
	I <sub>CCH</sub>	V <sub>CC</sub>	V <sub>CC</sub> = 3.3 V, T <sub>A</sub> = +25 °C	—	15	150	μA	When stopped and calender is not use (32 kHz stopped)
Input capacity	C <sub>IN</sub>	Other than V <sub>CC</sub> , V <sub>SS</sub> , AV <sub>CC</sub> , AV <sub>SS</sub> , and AVRH	—	—	10	—	pF	

\* : Refer to “■I/O CIRCUIT TYPE”.

# MB91F155A/MB91155/MB91154

## 4. Flash Memory Erase and Programming Performance

Parameter	Value			Unit	Remarks
	Min	Typ	Max		
Sector Erase Time	—	1 *	15 *	s	Excludes programming time prior to erasure
Half Word Programming Time	—	16 *	3600 *	μs	Excludes system-level overhead
Chip Programming Time	—	2.1 *	—	s	Excludes system-level overhead
Erase/Program Cycle	10000	—	—	cycle	

\* :  $T_A = +25\text{ }^\circ\text{C}$ ,  $V_{CC} = 3.3\text{ V}$

# MB91F155A/MB91155/MB91154

## 5. AC Characteristics

### (1) Clock Timing Ratings

( $V_{CC} = 3.15\text{ V to }3.6\text{ V}$ ,  $V_{SS} = AV_{SS} = 0\text{ V}$ ,  $T_A = 0\text{ }^{\circ}\text{C to }+70\text{ }^{\circ}\text{C}$ )

Parameter	Sym- bol	Pin name	Condition	Value		Unit	Remarks	
				Min	Max			
Clock frequency (High speed and self oscillation)	f <sub>c</sub>	X0, X1	—	10	16.5	MHz	Range in which self oscillation is allowed	
Clock frequency (High speed and PLL in use)			—				Range in which self oscillation and the use of the PLL for external clock input are allowed	
Clock frequency (High speed an 1/2 division input)			—	10	18	MHz	Range in which external clocks can be input	
Clock frequency (For calendar macro)	f <sub>CA</sub>	X0A, X1A	—	32		kHz	Self oscillation and external clocks	
Clock cycle time	t <sub>c</sub>	X0, X1	—	55.6	100	ns		
Clock pulse width	P <sub>WH</sub>	X0, X1	—	25	—			
	P <sub>WL</sub>		—	15	—			
Input clock rising	t <sub>cr</sub>	X0, X1	—	—	8		(t <sub>cr</sub> + t <sub>cf</sub> )	
Input clock falling	t <sub>cf</sub>		—					
Internal operating clock frequency	CPU system	f <sub>CP</sub>	—	One wait is set with the wait controller.	0.625* <sup>3</sup>	33	MHz	
	Bus system	f <sub>CPB</sub>			0.625* <sup>3</sup>	25* <sup>2</sup>		
	Peripheral system	f <sub>CPP</sub>			0.625* <sup>3</sup>	33	Analog section excluded. * <sup>1</sup>	
					1	33	Analog section * <sup>1</sup>	
Internal operat- ing clock cycle time	CPU system	t <sub>CP</sub>	—	One wait is set with the wait controller.	30.3	1600* <sup>3</sup>	ns	
	Bus system	t <sub>CPB</sub>			40* <sup>2</sup>	1600* <sup>3</sup>		
	Peripheral system	t <sub>CPP</sub>			30.3	1600* <sup>3</sup>	Analog section excluded. * <sup>1</sup>	
					30.3	1000	section * <sup>1</sup>	

\*1 : The target analog section is the A/D.

\*2 : The maximum external bus operating frequency allowed is 25 MHz.

\*3 : The value when a minimum clock frequency of 10 MHz is input to X0 and half a division of the oscillator circuit and the 1/8 gear are in use.

# MB91F155A/MB91155/MB91154

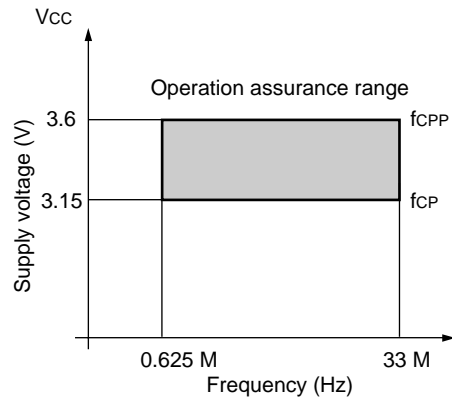
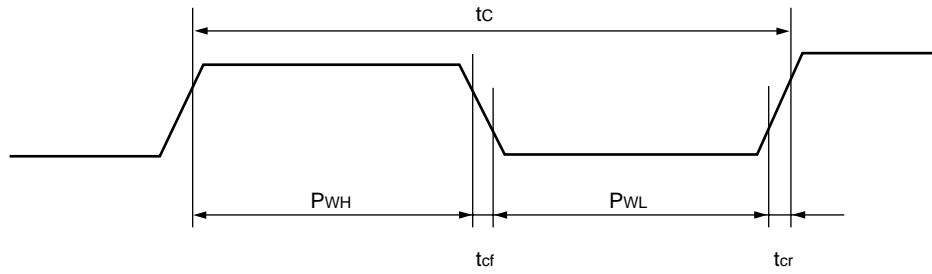

# MB91F155A/MB91155/MB91154

The relationship between the X0 input and the internal clock set with the CHC/CCK1/CCK0 bit of the GCR (Gear Control Register) is as shown next.

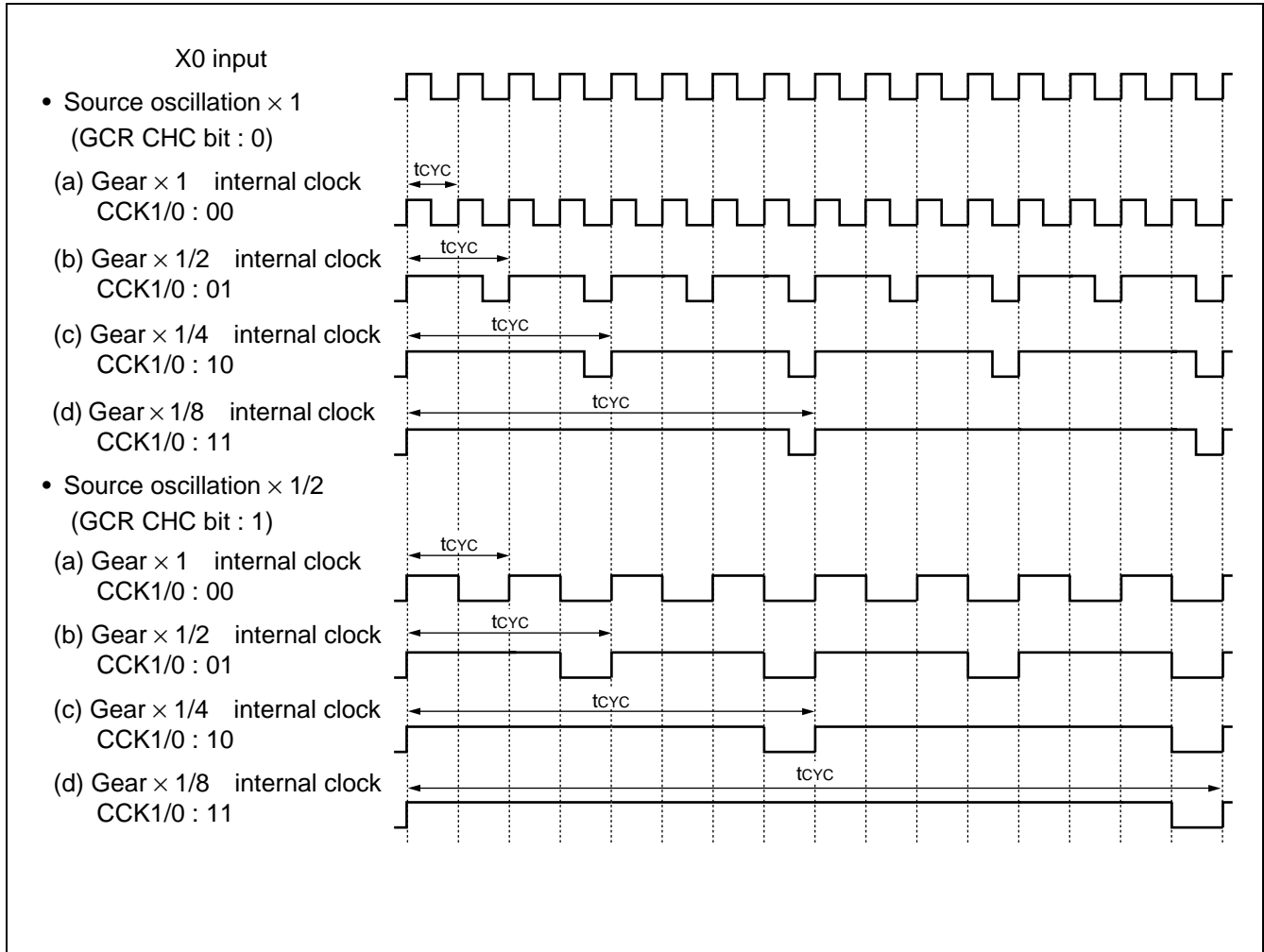

# MB91F155A/MB91155/MB91154

## (2) Clock Output Timing

( $V_{CC} = 3.15\text{ V to }3.6\text{ V}$ ,  $V_{SS} = AV_{SS} = 0\text{ V}$ ,  $T_A = 0\text{ }^{\circ}\text{C to }+70\text{ }^{\circ}\text{C}$ )

Parameter	Symbol	Pin name	Condition	Value		Unit	Remarks
				Min	Max		
Cycle time	$t_{CYC}$	CLK	—	$t_{CP}$		ns	*1
				$t_{CPB}$			On using doubla
CLK $\uparrow$ →CLK $\downarrow$	$t_{CHCL}$	CLK		$t_{CYC}/2-10$	$t_{CYC}/2+10$	ns	*2
CLK $\downarrow$ →CLK $\uparrow$	$t_{CLCH}$	CLK		$t_{CYC}/2-10$	$t_{CYC}/2+10$	ns	*3

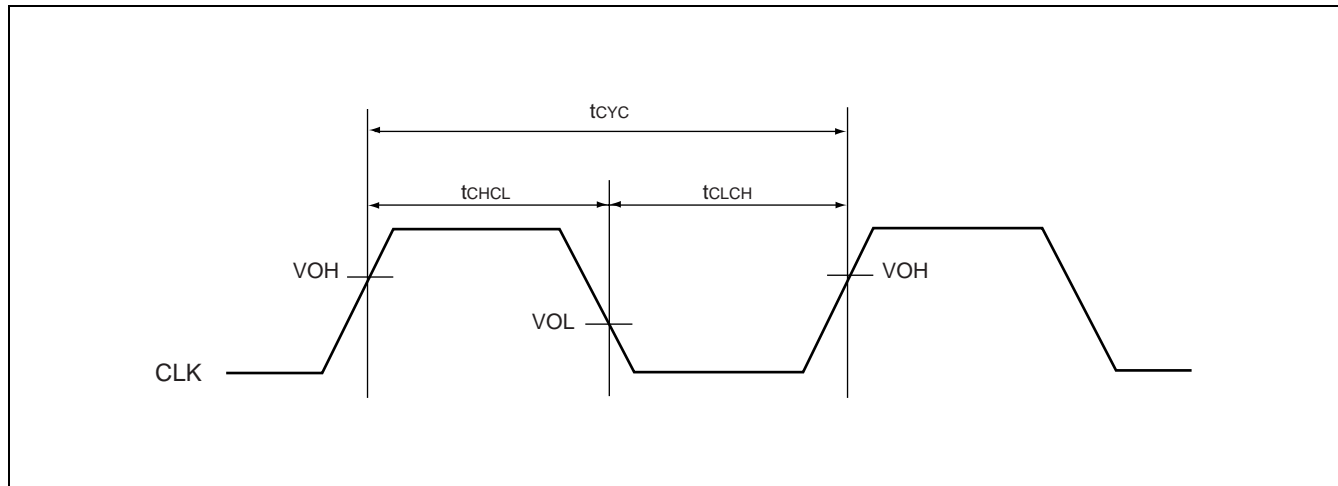

\*1 :  $t_{CYC}$  is a frequency for 1clock cycle including a gear cycle.  
Use the doublur when CPU frequency is above 25 MHz.

\*2 : Rating at a gear cycle of  $\times 1$

When a gear cycle of 1/2, 1/4, 1/8 is selected, substitute "n" in the following equations wiht 1/2, 1/4, 1/8, respectively.

- Min :  $(1-n/2) \times t_{CYC}-10$
- Max :  $(1-n/2) \times t_{CYC}+10$

Select a gear sycle of  $\times 1$  when using the doublur.

\*3 : Rating at a gear cycle of  $\times 1$

When a gear cycle of 1/2, 1/4, 1/8 selected, substitute "n" in the following equations wiht 1/2, 1/4, 1/8, respectively.

- Min :  $n/2 \times t_{CYC}-10$
- Max :  $n/2 \times t_{CYC}+10$

Select a gear sycle of  $\times 1$  when using the doublur.



# MB91F155A/MB91155/MB91154

## (3) Reset Input Ratings

( $V_{CC} = 3.15\text{ V to }3.6\text{ V}$ ,  $V_{SS} = AV_{SS} = 0\text{ V}$ ,  $T_A = 0\text{ }^{\circ}\text{C to }+70\text{ }^{\circ}\text{C}$ )

Parameter	Symbol	Pin name	Condition	Value		Unit	Remarks
				Min	Max		
Reset input time	$t_{RSTL}$	$\overline{\text{RST}}$	—	$t_{CP} \times 5$	—	ns	

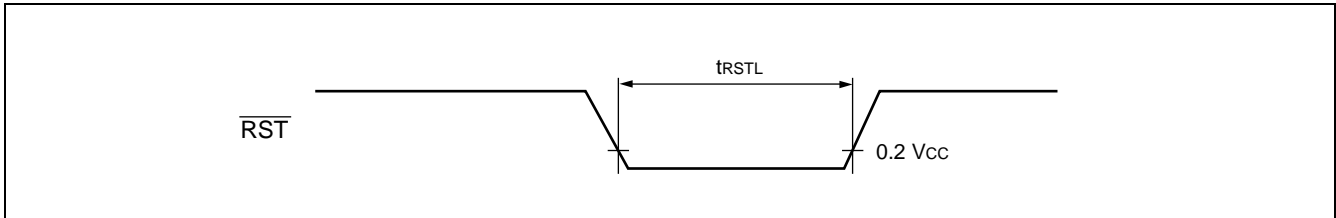

## (4) Power On Reset

( $V_{CC} = 3.15\text{ V to }3.6\text{ V}$ ,  $V_{SS} = AV_{SS} = 0\text{ V}$ ,  $T_A = 0\text{ }^{\circ}\text{C to }+70\text{ }^{\circ}\text{C}$ )

Parameter	Symbol	Pin name	Condition	Value		Unit	Remarks
				Min	Max		
Power supply rising time	$f_R$	$V_{CC}$	—	—	20	ms	$V_{CC} < 0.2\text{ V}$ before turning up the power.
Power supply cutoff time	$t_{OFF}$			2	—	ms	

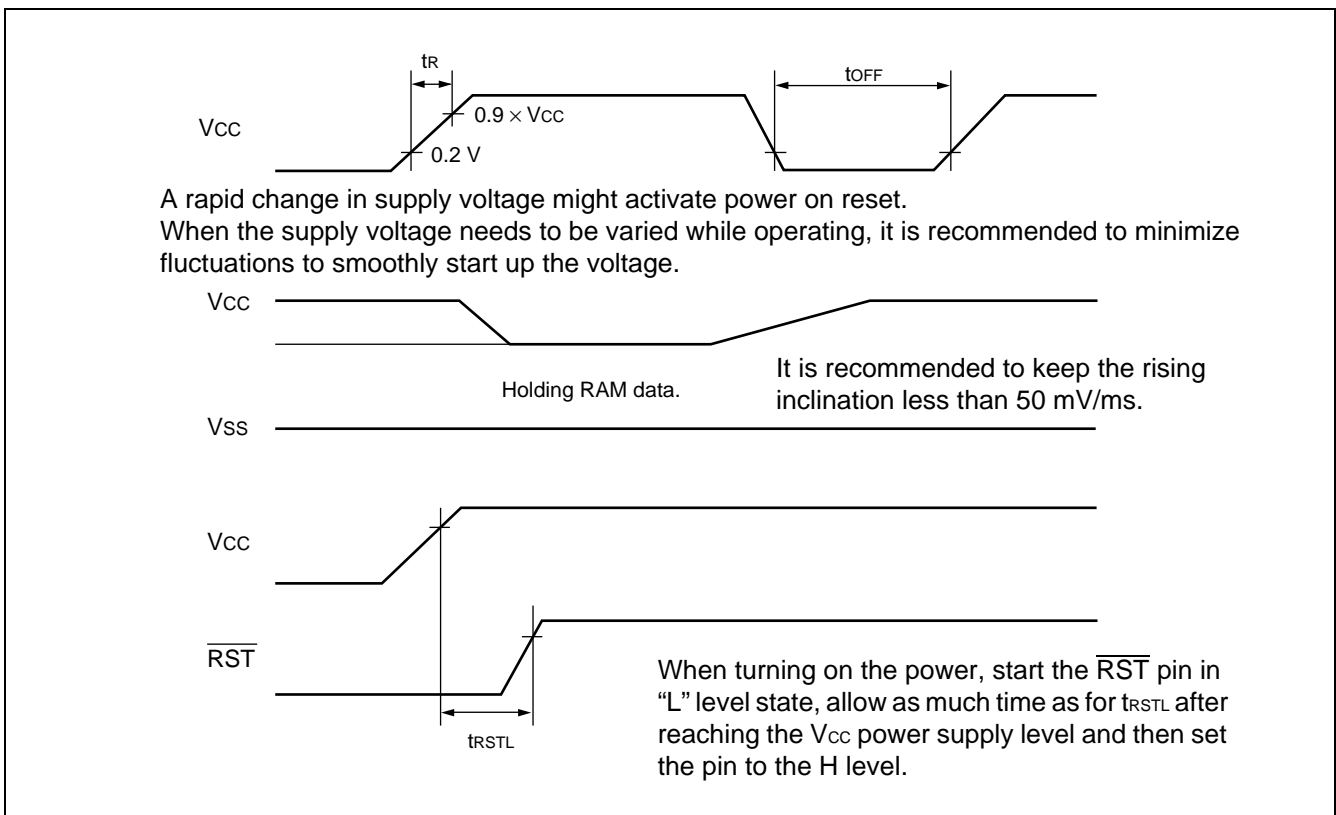

# MB91F155A/MB91155/MB91154

## (5) Serial I/O (CH0-4)

( $V_{CC} = 3.15\text{ V to }3.6\text{ V}$ ,  $V_{SS} = AV_{SS} = 0\text{ V}$ ,  $T_A = 0\text{ }^\circ\text{C to }+70\text{ }^\circ\text{C}$ )

Parameter	Symbol	Pin name	Condition	Value		Unit	Remarks
				Min	Max		
Serial clock cycle time	$t_{SCYC}$	—	Internal clock	$8 t_{CPP}$	—	ns	
SCK $\downarrow \rightarrow$ SO delay time	$t_{SLOV}$	—		-10	50	ns	
Valid SI $\rightarrow$ SCK $\uparrow$	$t_{IVSH}$	—		50	—	ns	
SCK $\uparrow \rightarrow$ valid SI hold time	$t_{SHIX}$	—		50	—	ns	
Serial clock "H" pulse width	$t_{SHSL}$	—	External clock	$4 t_{CPP} - 10$	—	ns	
Serial clock "L" pulse width	$t_{SLSH}$	—		$4 t_{CPP} - 10$	—	ns	
SCK $\downarrow \rightarrow$ SO delay time	$t_{SLOV}$	—		0	50	ns	
Valid SI $\rightarrow$ SCK $\uparrow$	$t_{IVSH}$	—		50	—	ns	
SCK $\uparrow \rightarrow$ valid SI hold time	$t_{SHIX}$	—		50	—	ns	
Serial busy period	$t_{BUSY}$	—		—	$6 t_{CPP}$	ns	
SCS $\downarrow \rightarrow$ SCK and SO delay time	$t_{CLZO}$	—		—	50	ns	
SCS $\downarrow \rightarrow$ SCK input mask time	$t_{CLSL}$	—		—	$3 t_{CPP}$	ns	
SCS $\uparrow \rightarrow$ SCK and SO Hi-Z time	$t_{CHOZ}$	—		50	—	ns	

### Internal shift clock mode

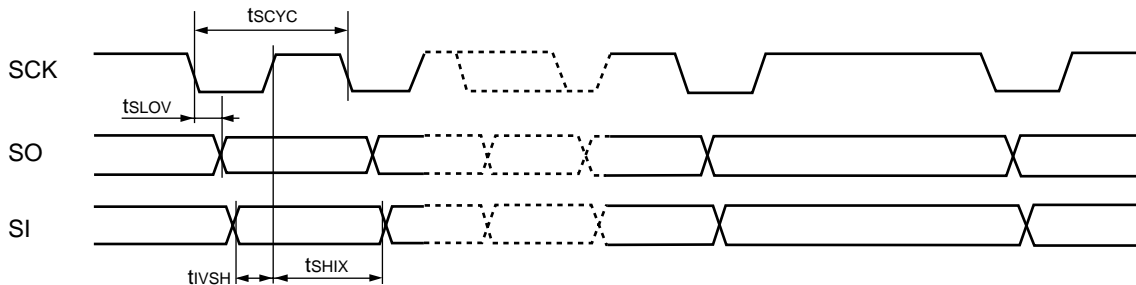

### External shift clock mode

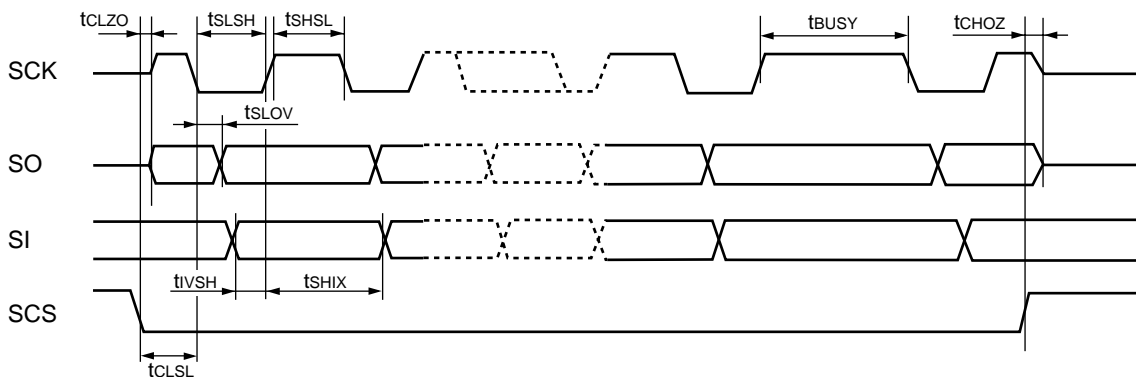

# MB91F155A/MB91155/MB91154

## (6) External Bus Measurement Conditions

The following conditions apply to items that are not specifically stipulated.

### • AC characteristics measurement conditions

$V_{CC} : 3.3 \text{ V}$

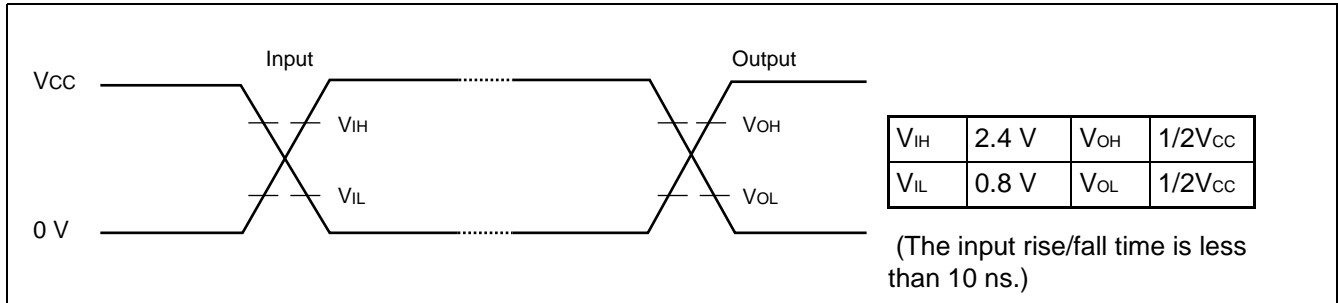

### • Load condition

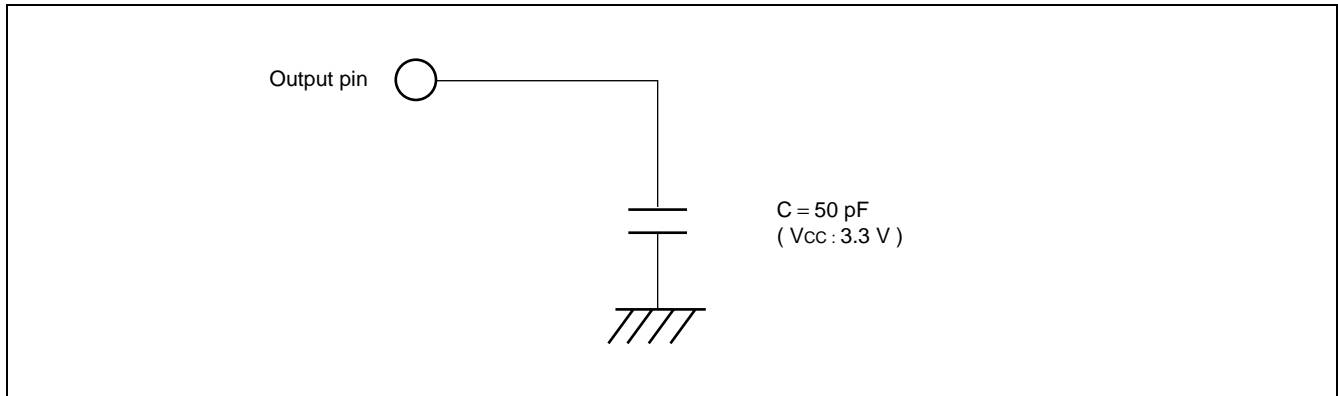

# MB91F155A/MB91155/MB91154

## (7) Normal Bus Access and Read/Write Operations

(V<sub>CC</sub> = 3.15 V to 3.6 V, V<sub>SS</sub> = AV<sub>SS</sub> = 0 V, T<sub>A</sub> = 0 °C to +70 °C)

Parameter	Symbol	Pin name	Condition	Value		Unit	Remarks
				Min	Max		
CS 0 - CS3 delay time	t <sub>CHCSL</sub>	CLK	—	—	15	ns	
CS 0 - CS3 delay time	t <sub>CHCSH</sub>	CS0 to CS3		—	15	ns	
Address delay time	t <sub>CHAV</sub>	CLK A23 to A00		—	15	ns	
Data delay time	t <sub>CHDV</sub>	CLK D31 to D16		—	15	ns	
$\overline{\text{RD}}$ delay time	t <sub>CLRL</sub>	CLK $\overline{\text{RD}}$		—	10	ns	
$\overline{\text{RD}}$ delay time	t <sub>CLRH</sub>			—	10	ns	
$\overline{\text{WR0}}$ - $\overline{\text{WR1}}$ delay time	t <sub>CLWL</sub>	CLK $\overline{\text{WR0}}$ to $\overline{\text{WR1}}$		—	10	ns	
$\overline{\text{WR0}}$ - $\overline{\text{WR1}}$ delay time	t <sub>CLWH</sub>			—	10	ns	
Valid address → valid data input time	t <sub>AVDV</sub>	A23 to A00 D31 to D16		—	$3/2 \times$ t <sub>cyC</sub> - 40	ns	*1, *2
$\overline{\text{RD}} \downarrow \rightarrow$ valid data input time	t <sub>RLDV</sub>	$\overline{\text{RD}}$ D31 to D16		—	t <sub>cyC</sub> - 25	ns	*1
Data setup → $\overline{\text{RD}} \uparrow$ time	t <sub>DSRH</sub>			25	—	ns	
$\overline{\text{RD}} \uparrow \rightarrow$ Rdata hold time	t <sub>RHDX</sub>			0	—	ns	

\*1 : If the bus is extended with either automatic wait insertion or RDY input, add the (t<sub>cyC</sub> × the number of extended cycles) time to this value.

\*2 : This is the value at the time of (gear cycle × 1) .

When the gear cycle is set to 1/2, 1/4 or 1/8, substitute “n” in the following formula with 1/2, 1/4 or 1/8 respectively.

$$\text{Formula : } (2 - n / 2) \times t_{\text{cyC}} - 40$$

# MB91F155A/MB91155/MB91154

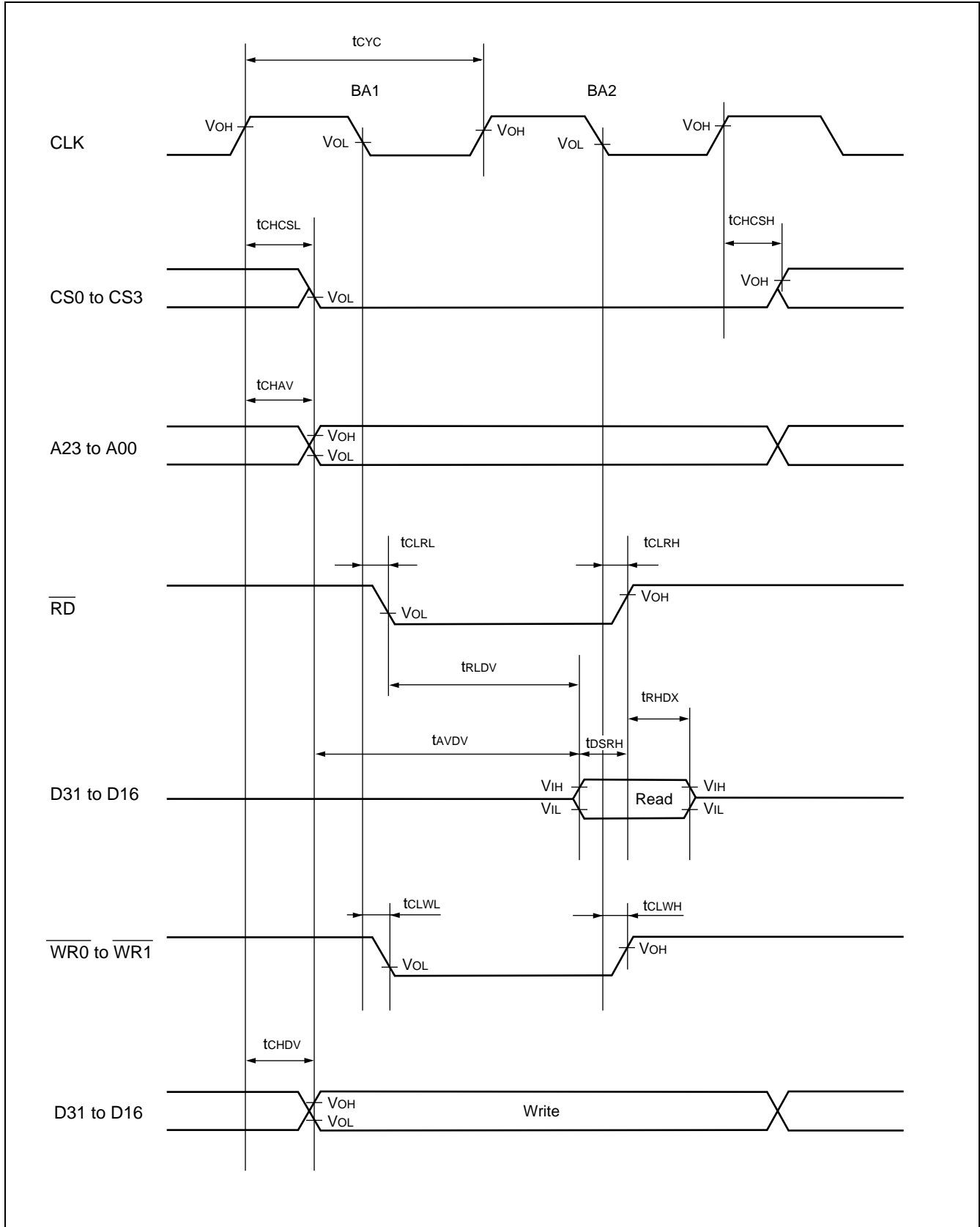

# MB91F155A/MB91155/MB91154

## (8) Ready Input Timing

( $V_{CC} = 3.15\text{ V to }3.6\text{ V}$ ,  $V_{SS} = AV_{SS} = 0\text{ V}$ ,  $T_A = 0\text{ }^{\circ}\text{C to }+70\text{ }^{\circ}\text{C}$ )

Parameter	Symbol	Pin name	Condition	Value		Unit	Remarks
				Min	Max		
RDY setup time $\rightarrow$ CLK $\downarrow$	$t_{RDYS}$	RDY CLK	—	20	—	ns	
CLK $\downarrow \rightarrow$ RDY hold time	$t_{RDYH}$	RDY CLK		0	—	ns	

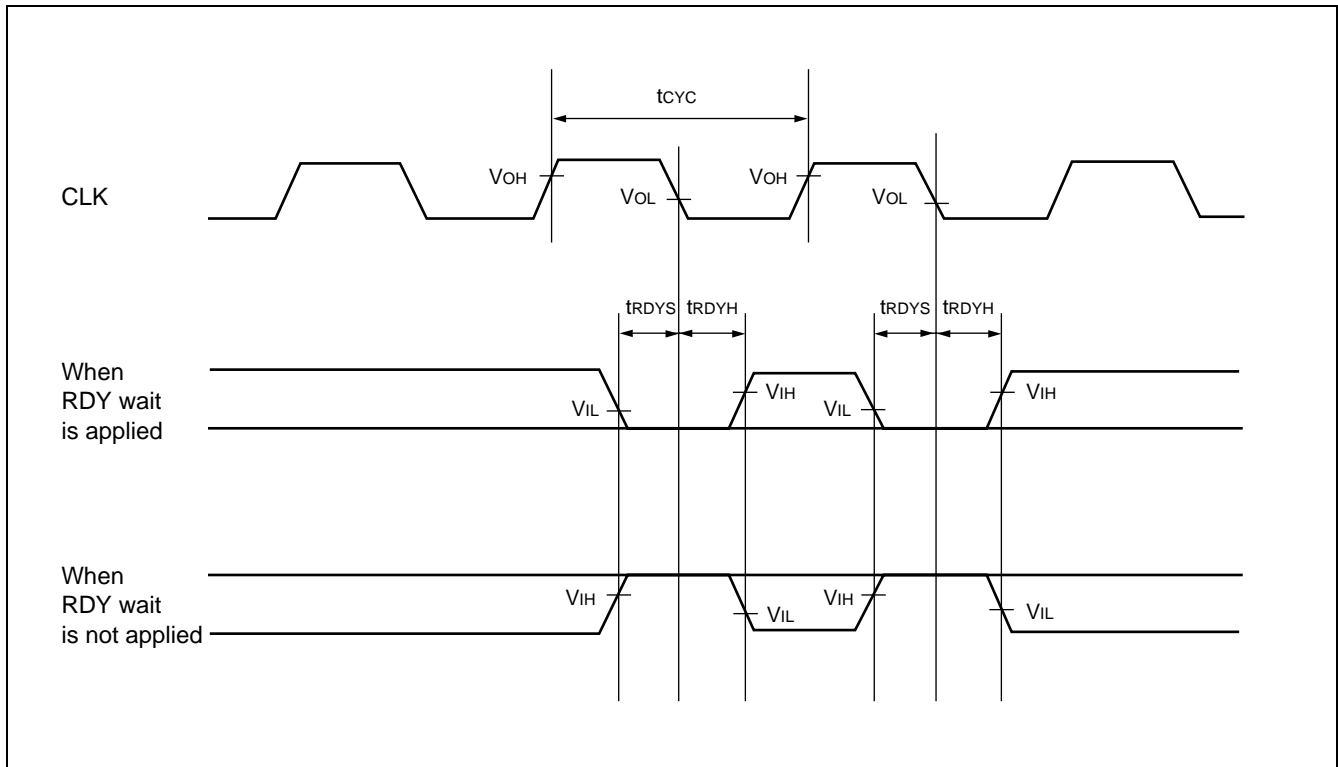

# MB91F155A/MB91155/MB91154

## (9) Hold Timing

( $V_{CC} = 3.15\text{ V to }3.6\text{ V}$ ,  $V_{SS} = AV_{SS} = 0\text{ V}$ ,  $T_A = 0\text{ }^{\circ}\text{C to }+70\text{ }^{\circ}\text{C}$ )

Parameter	Symbol	Pin name	Condition	Value		Unit	Remarks
				Min	Max		
$\overline{\text{BGRNT}}$ delay time	$t_{\text{CHBGL}}$	CLK	—	—	10	ns	
$\overline{\text{BGRNT}}$ delay time	$t_{\text{CHBGH}}$	$\overline{\text{BGRNT}}$		—	10	ns	
Pin floating $\rightarrow \overline{\text{BGRNT}}$ $\downarrow$ time	$t_{\text{XHAL}}$	$\overline{\text{BGRNT}}$		$t_{\text{CYC}} - 10$	$t_{\text{CYC}} + 10$	ns	
$\overline{\text{BGRNT}}$ $\uparrow \rightarrow$ Pin valid time	$t_{\text{HAHV}}$			$t_{\text{CYC}} - 10$	$t_{\text{CYC}} + 10$	ns	

Note : More than one cycle exist after BRQ is fetched and before  $\overline{\text{BGRNT}}$  changes.

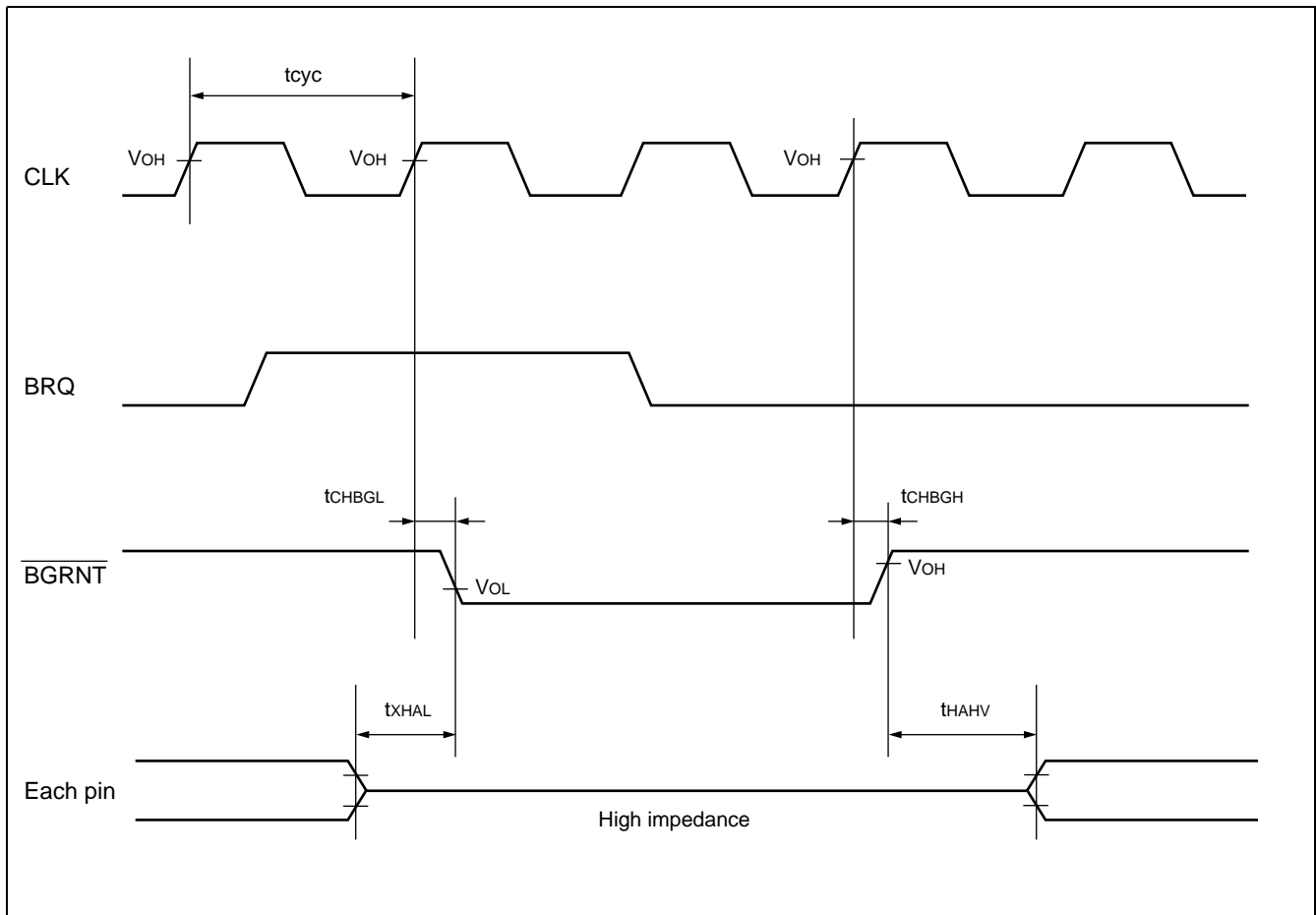

# MB91F155A/MB91155/MB91154

## (9) DMA Controller Timing

( $V_{CC} = 3.15\text{ V to }3.6\text{ V}$ ,  $V_{SS} = AV_{SS} = 0\text{ V}$ ,  $T_A = 0\text{ }^{\circ}\text{C to }+70\text{ }^{\circ}\text{C}$ )

Parameter	Symbol	Pin name	Condition	Value		Unit	Remarks
				Min	Max		
DREQ input pulse width	$t_{DRWH}$	DREQ0 to DREQ2	—	$2\ t_{CYC}$	—	ns	
DACK delay time (typical bus) (typical DRAM)	$t_{CLDL}$	CLK DACK0 to DACK2		—	6	ns	
	$t_{CLDH}$			—	6	ns	
DEOP delay time (typical bus) (typical DRAM)	$t_{CLEL}$	CLK DEOP0 to DEOP2		—	6	ns	
	$t_{CLEH}$			—	6	ns	
DACK delay time (Single Dram) (Hyper Dram)	$t_{CHDL}$	CLK DACK0 to DACK2		—	$n / 2 \times t_{CYC}$	ns	
	$t_{CHDH}$			—	6	ns	
DEOP delay time (Single Dram) (Hyper Dram)	$t_{CHEL}$	CLK DEOP0 to DEOP2		—	$n / 2 \times t_{CYC}$	ns	
	$t_{CHEH}$		—	6	ns		

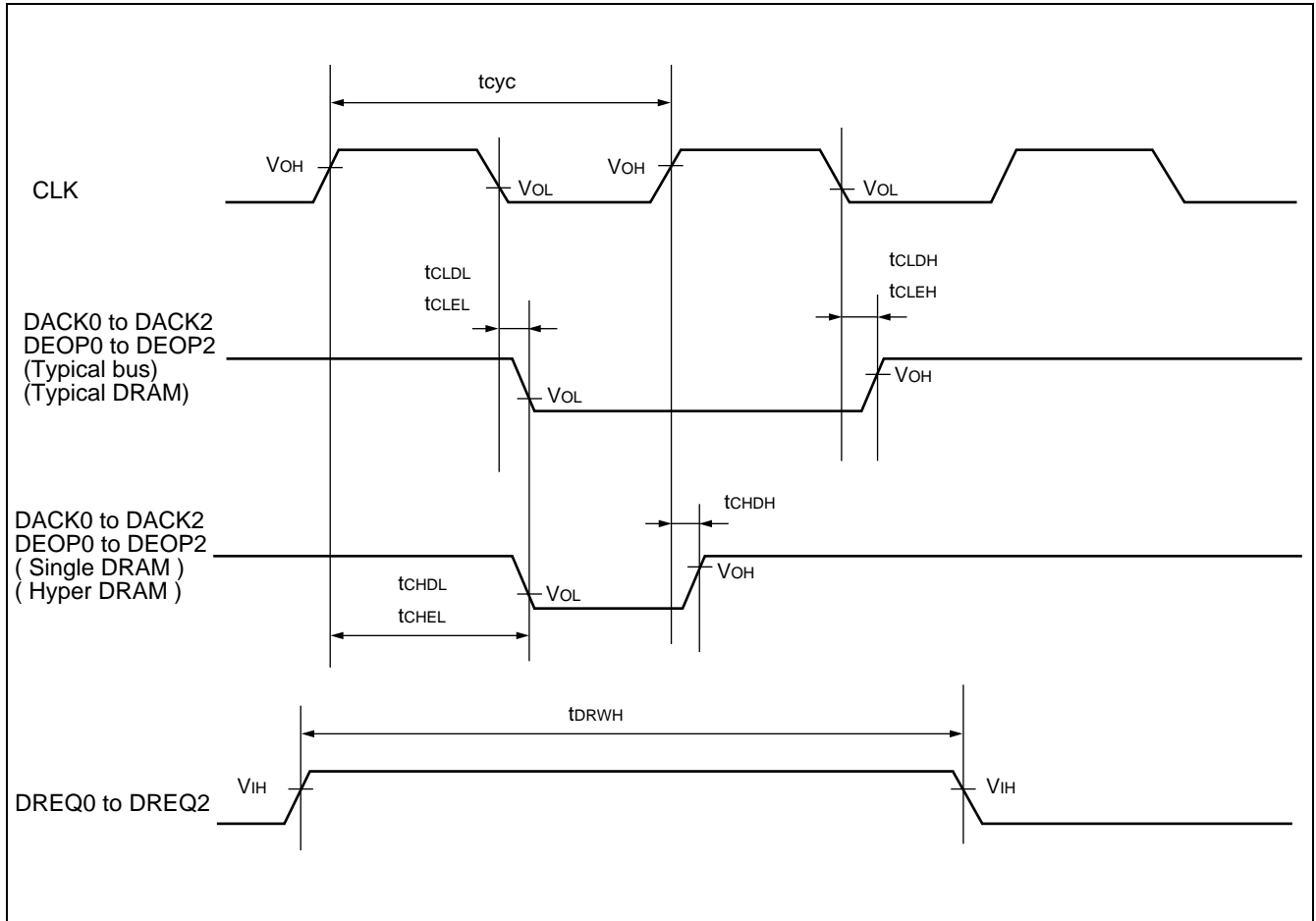



# MB91F155A/MB91155/MB91154

## 6. A/D Converter Electrical Characteristics

(V<sub>CC</sub> = 3.15 V to 3.6 V, V<sub>SS</sub> = AV<sub>SS</sub> = 0 V, T<sub>A</sub> = 0 °C to +70 °C)

Parameter	Symbol	Pin name	Condition	Value			Unit	Remarks	
				Min	Typ	Max			
Resolution	—	—	—	—	—	10	Bit		
Conversion time	—	—		5.1	—	—	μs		
Total error	—	—	AV <sub>CC</sub> = 3.3 V, AV <sub>RH</sub> = 3.3 V	—	—	±4.0	LSB		
Linearity error	—	—		—	—	±3.5	LSB		
Differential linearity error	—	—		—	—	±2.0	LSB		
Zero transition error	V <sub>OT</sub>	AN0 to AN7	AV <sub>CC</sub> = 3.3 V, AV <sub>RH</sub> = 3.3 V	AV <sub>SS</sub> - 1.5	AV <sub>SS</sub> + 0.5	AV <sub>SS</sub> + 2.5	LSB		
Full-scale transition error	V <sub>FST</sub>	AN0 to AN7		AV <sub>RH</sub> - 5.5	AV <sub>RH</sub> - 1.5	AV <sub>RH</sub> + 0.5	LSB		
Analog input current	I <sub>AIN</sub>	AN0 to AN7	—	—	0.1	10	μA		
Analog input voltage	V <sub>AIN</sub>	AN0 to AN7		AV <sub>SS</sub>	—	AV <sub>RH</sub>	V		
Reference voltage	AV <sub>RH</sub>	AV <sub>RH</sub>	—	—	—	AV <sub>CC</sub>	V		
Supply current	Conversion in operation	I <sub>A</sub>	AV <sub>CC</sub>	AV <sub>CC</sub> = 3.3 V	—	3.0	5.0	mA	
	Conversion stopped	I <sub>AH</sub>			—	—	5.0	μA	
Reference voltage supply current	Conversion in operation	I <sub>R</sub>	AV <sub>RH</sub>	AV <sub>CC</sub> = 3.3 V, AV <sub>RH</sub> = 3.3 V	—	2.0	3.0	mA	
	Conversion stopped	I <sub>RH</sub>			—	—	10	μA	
Interchannel variation	—	AN0 to AN7	—	—	—	4	LSB		

- Notes :
- The smaller the |AV<sub>RH</sub>| is, the greater the error is in general.
  - The external circuit output impedance of analog input should be used in compliance with the following requirements :  
External circuit output impedance ≤ 2 (kΩ)  
If the output impedance of the external circuit is too high, an analog voltage sampling duration shortage might occur. (Sampling duration = 1.4 μs : @33 MHz)

# MB91F155A/MB91155/MB91154

## • A/D Converter Glossary

- Resolution : Analog changes that are identifiable by the A/D converter.
- Linearity error : The deviation of the straight line connecting the zero transition point (00 0000 0000  $\leftrightarrow$  00 0000 0001) with the full-scale transition point (11 1111 1110  $\leftrightarrow$  11 1111 1111) from actual conversion characteristics.
- Differential linearity error : The deviation of input voltage needed to change the output code by one LSB from the theoretical value.
- Total error : The difference between actual and theoretical conversion values including a zero transition/full-scale transition/linearity error.

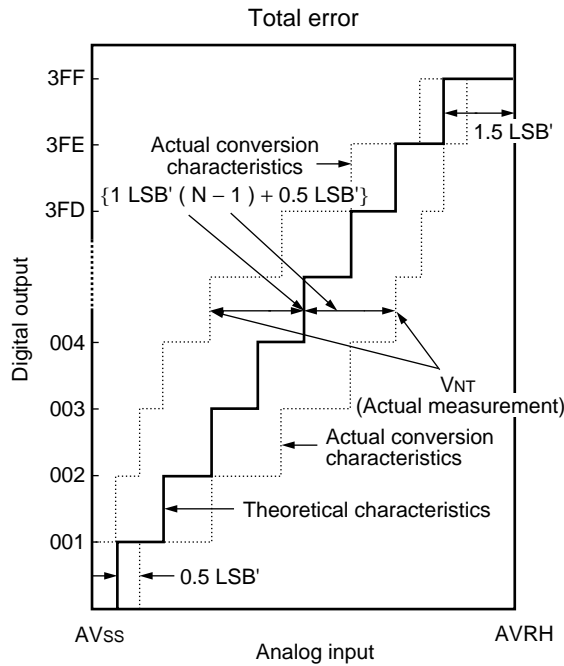

$$1 \text{ LSB}' \text{ (theoretical value)} = \frac{\text{AVRH} - \text{AVSS}}{1024} \quad [\text{V}]$$

$$V_{0T}' \text{ (theoretical value)} = \text{AVSS} + 0.5 \text{ LSB}' \quad [\text{V}]$$

$$V_{FST}' \text{ (theoretical value)} = \text{AVRH} - 1.5 \text{ LSB}' \quad [\text{V}]$$

$$\text{Total error of digital output } N = \frac{V_{NT} - \{1 \text{ LSB}' \times (N - 1) + 0.5 \text{ LSB}'\}}{1 \text{ LSB}'}$$

$V_{NT}$  : Voltage at which digital output changes from (N + 1) to N.

(Continued)

# MB91F155A/MB91155/MB91154

(Continued)

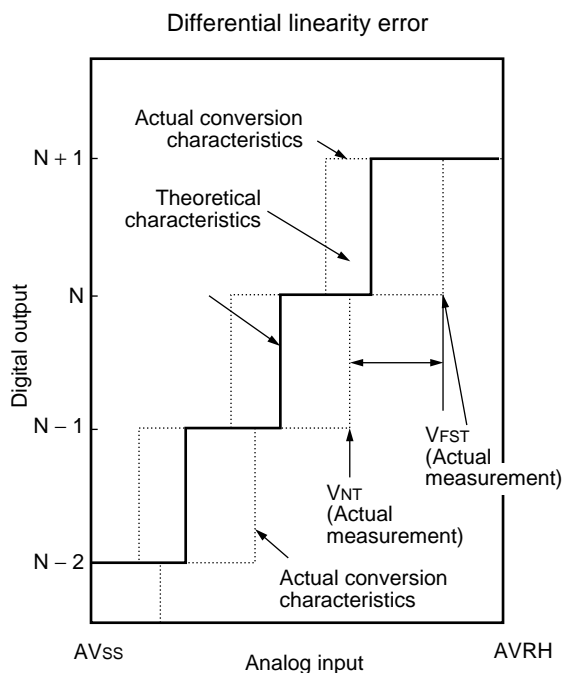
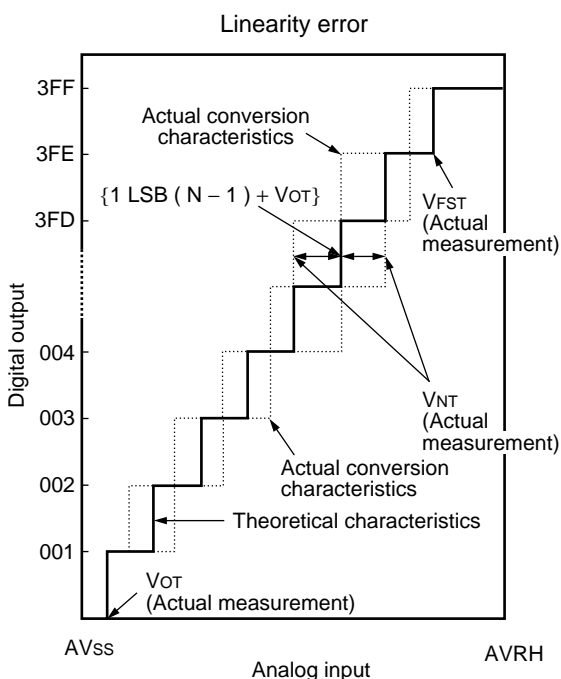

$$\text{Linearity error of digital output } N = \frac{V_{NT} - \{1 \text{ LSB} \times (N - 1) + V_{OT}\}}{1 \text{ LSB}} \quad [\text{LSB}]$$

$$\text{Differential linearity error of digital output } N = \frac{V_{(N+1)T} - V_{NT}}{1 \text{ LSB}} - 1 \quad [\text{LSB}]$$

$$1 \text{ LSB} = \frac{V_{FST} - V_{OT}}{1022} \quad [\text{V}]$$

$V_{OT}$  : Voltage at which digital output changes from (000)<sub>H</sub> to (001)<sub>H</sub>.

$V_{FST}$  : Voltage at which digital output changes from (3FE)<sub>H</sub> to (3FF)<sub>H</sub>.

## 7. D/A Converter Electrical Characteristics

( $V_{CC} = 3.15 \text{ V to } 3.6 \text{ V}$ ,  $V_{SS} = AV_{SS} = 0 \text{ V}$ ,  $T_A = 0 \text{ }^\circ\text{C to } +70 \text{ }^\circ\text{C}$ )

Parameter	Symbol	Pin name	Condition	Value			Unit	Remarks
				Min	Typ	Max		
Resolution	—	—	—	—	—	8	Bit	
Differential linearity error	—	—	—	—	—	1	LSB	
Conversion time	—	—	—	—	—	20	$\mu\text{s}$	*
Analog output impedance	—	—	—	—	29	—	$\text{k}\Omega$	

\* :  $CL = 20 \text{ pF}$

# MB91F155A/MB91155/MB91154

## EXAMPLE CHARACTERISTICS

(1) "H" level output voltage

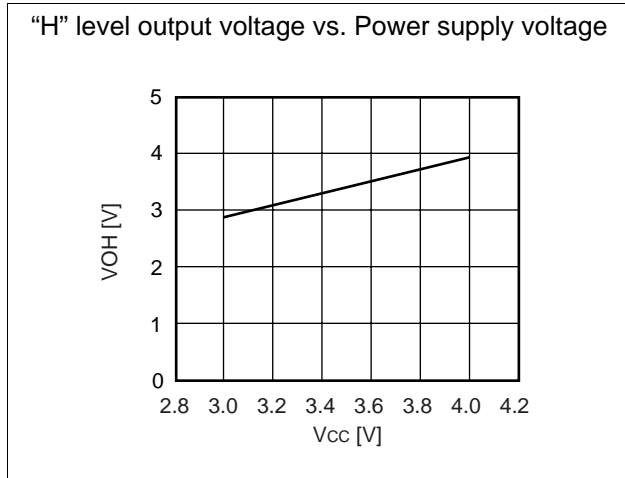

(2) "L" level output voltage

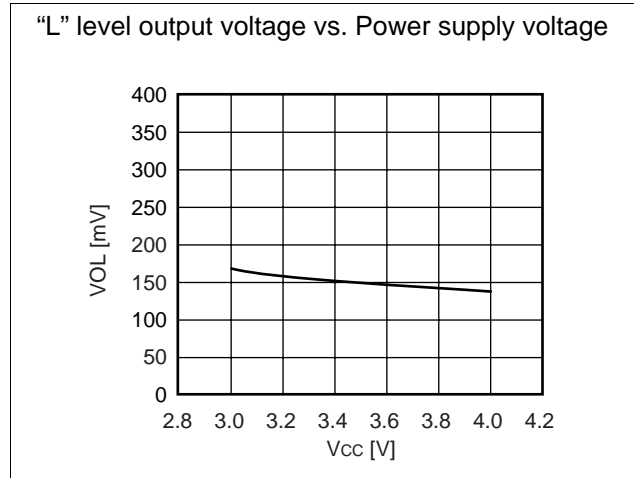

(3) "L" level output voltage (Open drain)

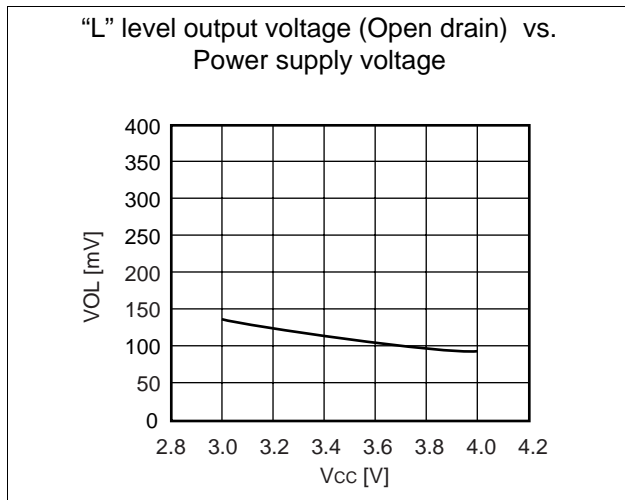

(4) Pull-up resistance

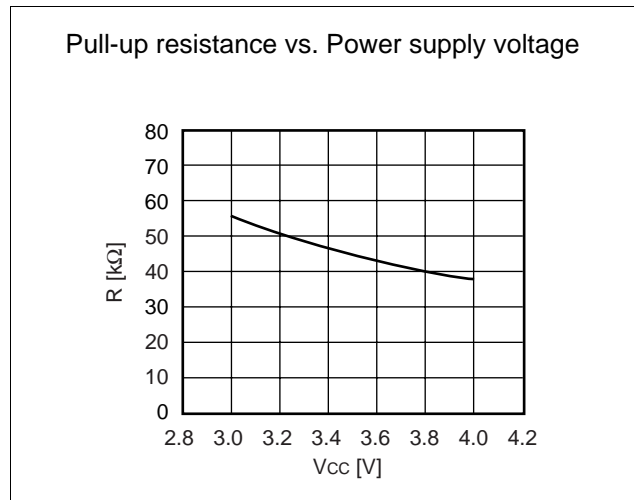

# MB91F155A/MB91155/MB91154

(5) Power supply

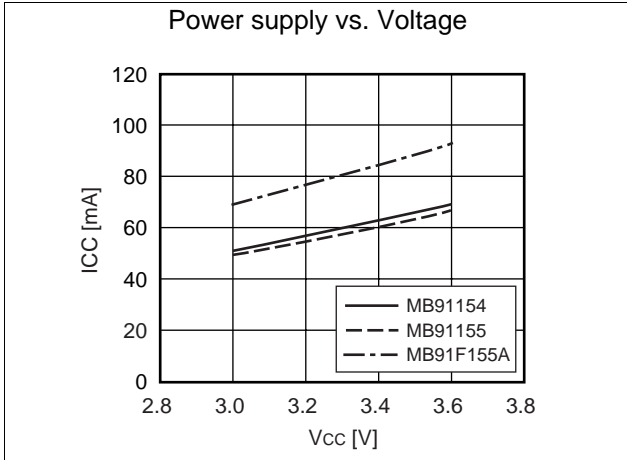

(6) Power supply at sleeping

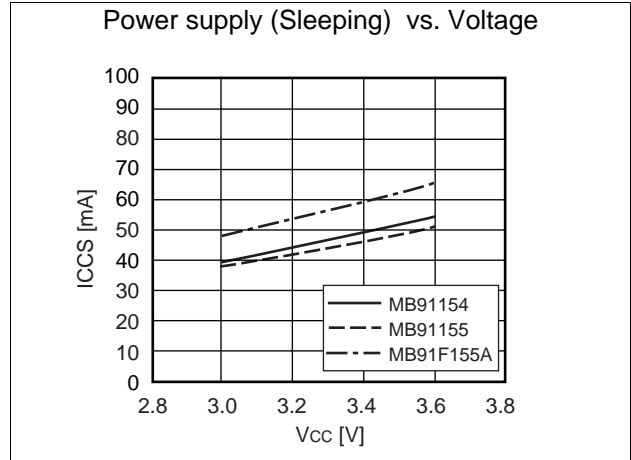

(7) Power supply at stopping

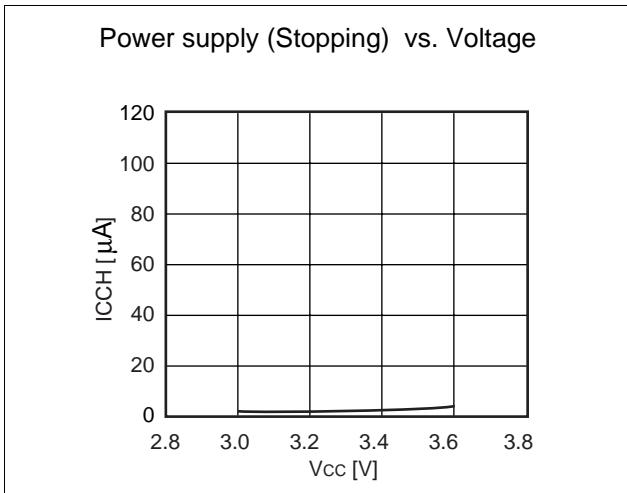

(8) A/D conversion power supply

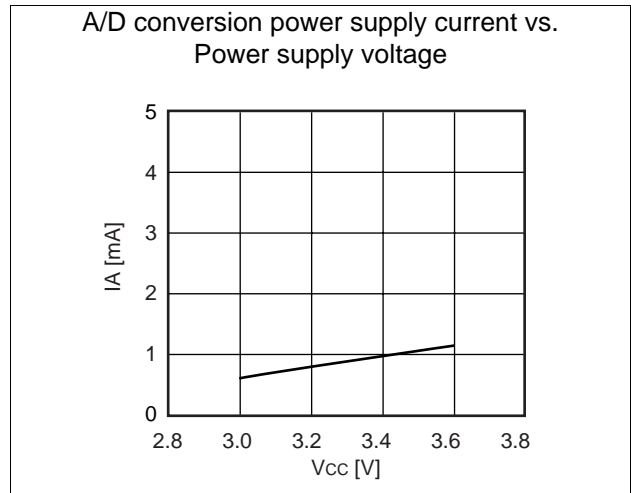

(9) A/D conversion reference voltage supply current (33 MHz)

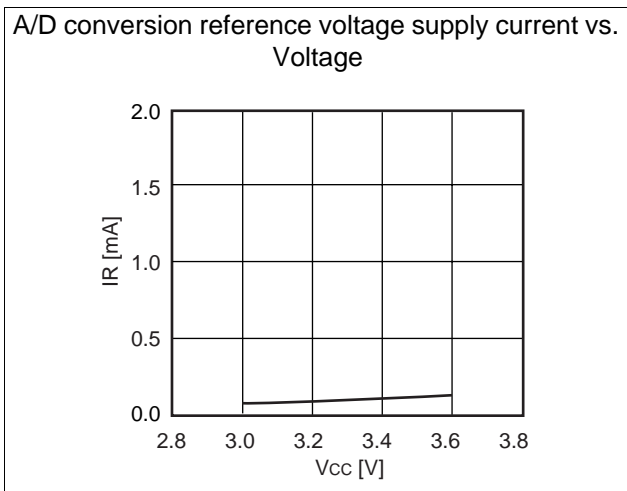

(10) D/A conversion power supply current (33 MHz)

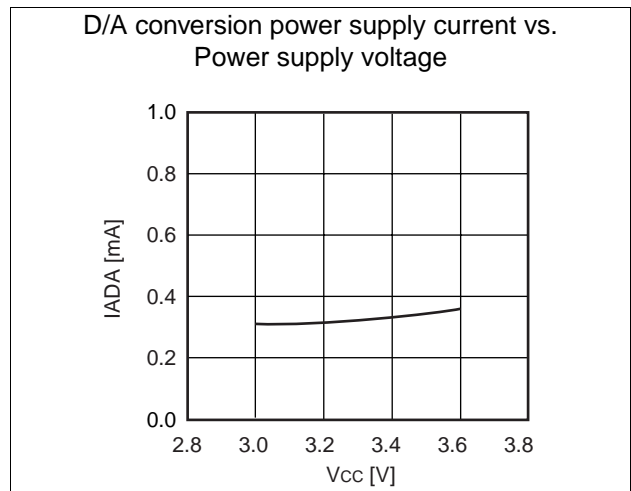

# MB91F155A/MB91155/MB91154

## ■ ORDERING INFORMATION

Part number	Package	Remarks
MB91F155APFV-G MB91155PFV-G-XXX MB91154PFV-G-XXX	144-pin plastic LQFP (FPT-144P-M08)	
MB91F155APF-G	144-pin plastic LQFP (FPT-144P-M01)	

# MB91F155A/MB91155/MB91154

## ■ PACKAGE DIMENSION

144-pin plastic LQFP  
(FPT-144P-M08)

\*Pins width and pins thickness include plating thickness.

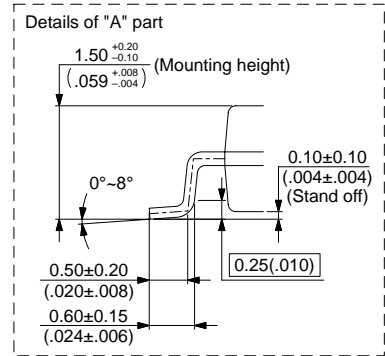
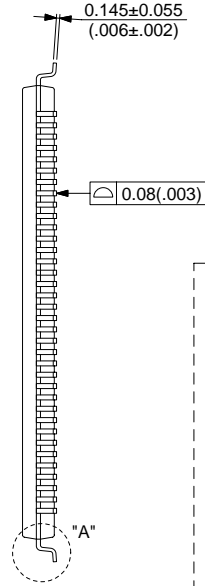
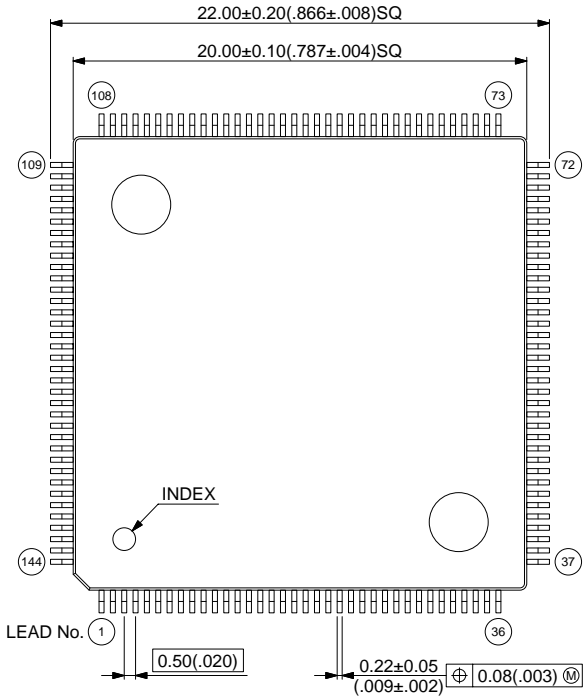

© 2000 FUJITSU LIMITED F144019S-c-2-4

Dimensions in mm (inches)

(Continued)

# MB91F155A/MB91155/MB91154

(Continued)

144-pin plastic LQFP  
(FPT-144P-M01)  
(MB91F155A only)

\*Pins width and pins thickness include plating thickness.

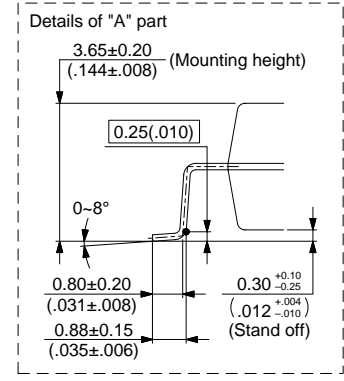
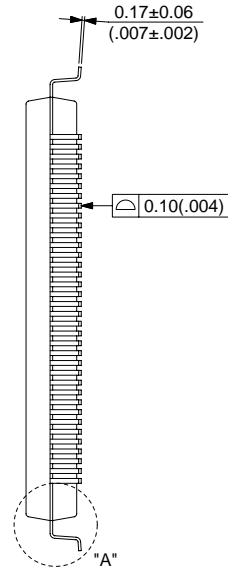
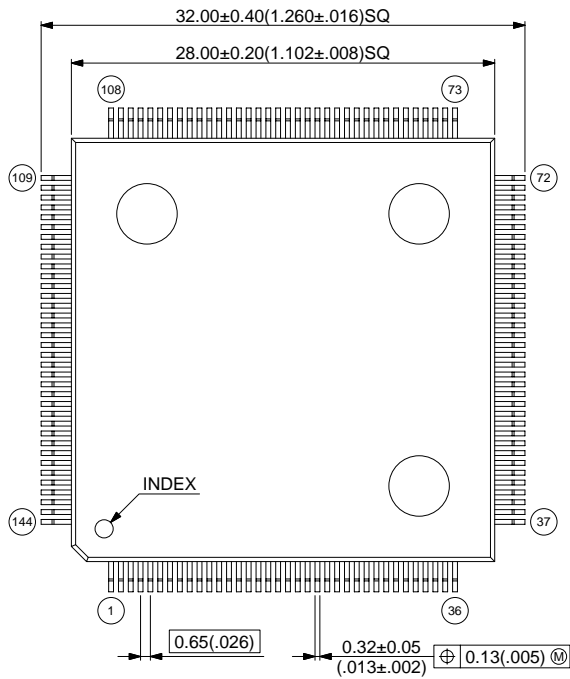

© 2001 FUJITSU LIMITED F144002S-c-4-4

Dimensions in mm (inches)



# MB91F155A/MB91155/MB91154

## FUJITSU LIMITED

All Rights Reserved.

The contents of this document are subject to change without notice. Customers are advised to consult with FUJITSU sales representatives before ordering.

The information and circuit diagrams in this document are presented as examples of semiconductor device applications, and are not intended to be incorporated in devices for actual use. Also, FUJITSU is unable to assume responsibility for infringement of any patent rights or other rights of third parties arising from the use of this information or circuit diagrams.

The products described in this document are designed, developed and manufactured as contemplated for general use, including without limitation, ordinary industrial use, general office use, personal use, and household use, but are not designed, developed and manufactured as contemplated (1) for use accompanying fatal risks or dangers that, unless extremely high safety is secured, could have a serious effect to the public, and could lead directly to death, personal injury, severe physical damage or other loss (i.e., nuclear reaction control in nuclear facility, aircraft flight control, air traffic control, mass transport control, medical life support system, missile launch control in weapon system), or (2) for use requiring extremely high reliability (i.e., submersible repeater and artificial satellite).

Please note that Fujitsu will not be liable against you and/or any third party for any claims or damages arising in connection with above-mentioned uses of the products.

Any semiconductor devices have an inherent chance of failure. You must protect against injury, damage or loss from such failures by incorporating safety design measures into your facility and equipment such as redundancy, fire protection, and prevention of over-current levels and other abnormal operating conditions.

If any products described in this document represent goods or technologies subject to certain restrictions on export under the Foreign Exchange and Foreign Trade Law of Japan, the prior authorization by Japanese government will be required for export of those products from Japan.

F0206

© FUJITSU LIMITED Printed in Japan