

APL1431



Adjustable Precision Shunt Regulator

Features

- Precise Reference Voltage to 2.500V
- Guaranteed 0.5% or 1% Reference Voltage Tolerance
- Sink Current Capability , 1mA to 100mA
- Quick Turn-on
- Adjustable Output Voltage , $V_O = V_{REF}$ to 20V
- Low Operational Cathode Current , 250 μ A Typical
- 0.1 Ω Typical Output Impedance
- SOT-23 , SOT-89 and TO-92 Packages

General Description

The APL1431 is a 3-terminal adjustable voltage reference with specified thermal stability over applicable commercial temperature ranges. Output voltage may be set to any value between V_{ref} (2.5 V) and 20 V with two external resistors (see Figure 2). When used with an photocoupler, the APL1431 is an ideal voltage reference in isolated feedback circuits for 2.5V to 12V switching-mode power supplies. This device has a typical output impedance of 0.1 Ω . Active output circuitry provides a very sharp turn-on characteristic, making the APL1431 excellent replacements for zener diodes in many applications, including on-board regulation and adjustable power supplies.

Applications

- Linear Regulators
- Adjustable Power Supply
- Switching Power Supply

Symbol



Functional Diagram

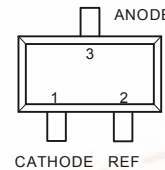
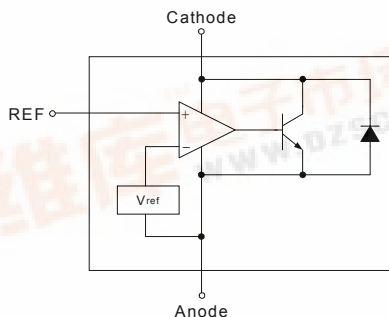

SOT-23 (Top View)

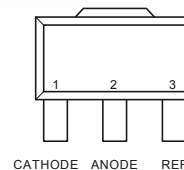

SOT-89 (Top View)

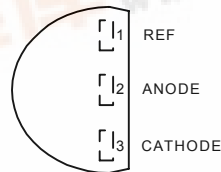

TO-92 (Top View)

ANPEC reserves the right to make changes to improve reliability or manufacturability without notice, and advise customers to obtain the latest version of relevant information to verify before placing orders.

Ordering and Marking Information

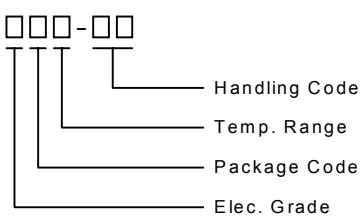
<p>APL1431 □□□-□□</p>  <p>Handling Code Temp. Range Package Code Elec. Grade</p>	<p>Elec. Grade A : 0.5% Reference Voltage Tolerance B : 1% Reference Voltage Tolerance</p> <p>Package Code A : SOT-23 D : SOT-89 E : TO-92 Y : Chip Form</p> <p>Temp. Range C : 0 to 70 °C I : -40 to 85 °C</p> <p>Handling Code PB : Plastic Bag TB : Tape & Box TR : Tape & Reel</p>
APL1431 A : □1431	APL1431 E : □APL □1431 □XXXXX XXXXX - Date Code
APL1431 D : □APL1431 □XXXXX XXXXX - Date Code	

Absolute Maximum Ratings

Symbol	Parameter	Rating	Unit
V_{KA}	Cathode voltage	20	V
I_K	Continuous cathode current range	120	mA
I_{REF}	Reference current range	3	mA
θ_{JA}	Thermal Resistance from Junction to Ambient in Free Air	SOT-23	416
		SOT-89	250
		TO-92	250
T_A	Ambient temperature range	APL1431XXC	0 to 70
		APL1431XXI	-40 to 85
T_j	Junction temperature range	APL1431XXC	0 to 150
		APL1431XXI	-40 to 150
T_{STG}	Storage Temperature Range	-65 to 150	°C
T_{SOL}	Lead temperature range, T_s (Soldering, 10sec)	260	°C

Electrical Characteristics $T_A = 25^\circ\text{C}$ (unless otherwise noted)

Symbol	Parameter	Test Conditions	APL1431			Unit
			Min.	Typ.	Max.	
V_{REF}	Reference voltage	$V_{KA}=V_{REF}, I_K=10\text{mA}^{*1}$ APL431A	2.487	2.500	2.513	V
		APL431B	2.475	2.500	2.525	
$\Delta V_{REF}/T$	Reference voltage drift over temp. range	$V_{KA}=V_{REF}, I_K=10\text{mA}$ $T_A = 0 \text{ to } 70^\circ\text{C}^{*1}$ $T_A = -40 \text{ to } 85^\circ\text{C}^{*1}$			20 30	mV
$\Delta V_{REF} / \Delta V_{KA}$	Voltage ratio (open loop gain)	$I_K=10\text{mA}, V_{KA}=V_{REF} \text{ to } 10\text{V}^{*2}$		-1.5	-3	mV/V
		$I_K=10\text{mA}, V_{KA}=V_{REF} \text{ to } 20\text{V}^{*2}$		-1.2	-2.5	

Electrical Characteristics Cont. $T_A = 25^\circ\text{C}$ (unless otherwise noted)

Symbol	Parameter	Test Conditions	APL1431			Unit
			Min.	Typ.	Max.	
I_{REF}	Reference current	$I_K = 10\text{mA}$, $R_1 = 10\text{k}\Omega$, $R_2 = \text{open}^{*2}$		1.0	3	μA
$\Delta I_{REF}/T$	Reference current drift	$I_K = 10\text{mA}$, $R_1 = 10\text{k}\Omega$, $R_2 = \text{open}$, $T_A = -40$ to 85°C^{*2}		0.3	1	μA
$I_{K(\text{min})}$	Min. cathode current	$V_{KA} = V_{REF}^{*1}$		0.25	0.5	mA
$I_{K(\text{off})}$	Off-state cathode current	$V_{KA} = 20\text{V}$, $V_{REF} = 0\text{V}^{*3}$		0.1	1	μA
$ Z_{KA} $	Dynamic impedance	$V_{KA} = V_{REF}$ $I_K = 1\text{mA}$ to 100mA , $f \leq 1\text{kHz}^{*1}$		0.1	0.4	Ω
I_K	Cathode current	$V_{KA} = V_{REF} + 50\text{mV}^{*2}$			100	mA

Notes : *1 : use Figure 1
 *2 : use Figure 2
 *3 : use Figure 3

Test figures

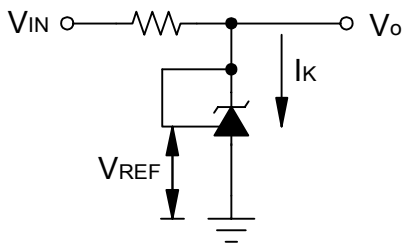

Figure 1. Test Circuit for $V_{KA} = V_{REF}$, $V_O = V_{KA} = V_{REF}$

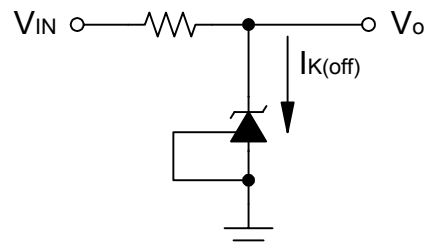

Figure 3. Test Circuit for $I_{K(\text{off})}$

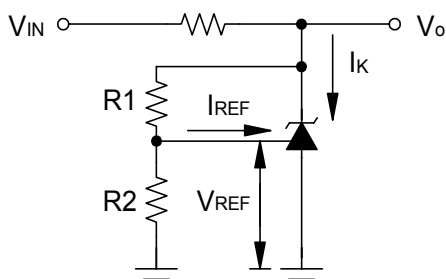
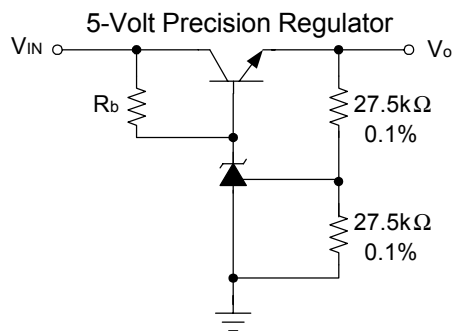

Figure 2. Test Circuit for $V_{KA} > V_{REF}$
 $V_O = V_{KA} = V_{REF} \times (1 + R_1/R_2) + I_{REF} \times R_1$

Application schematic



* R_b should provide cathode current large than 1mA to maintain APL431 work properly.

Typical Characteristics

Reference Current vs. Temperature

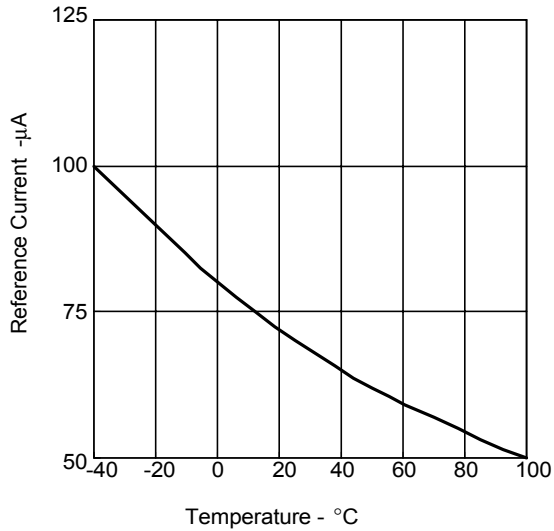

Cathode Current vs. Cathode Voltage

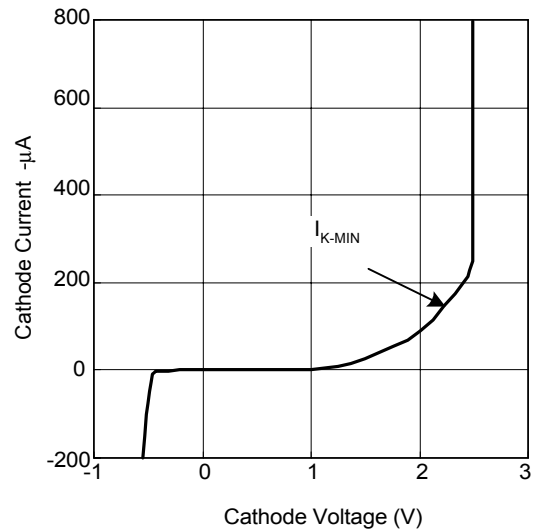

Cathode Current vs. Cathode Voltage

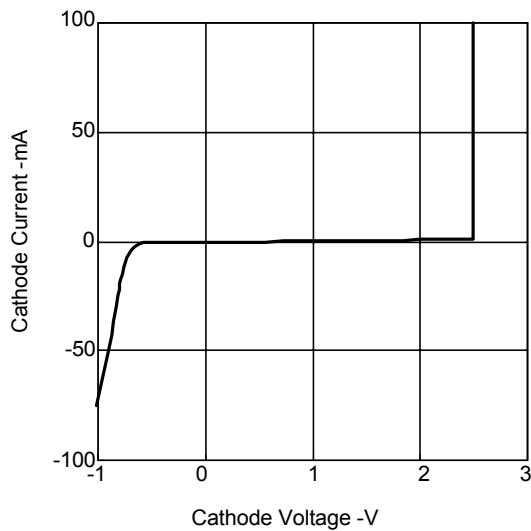

Reference Voltage vs. Temperature

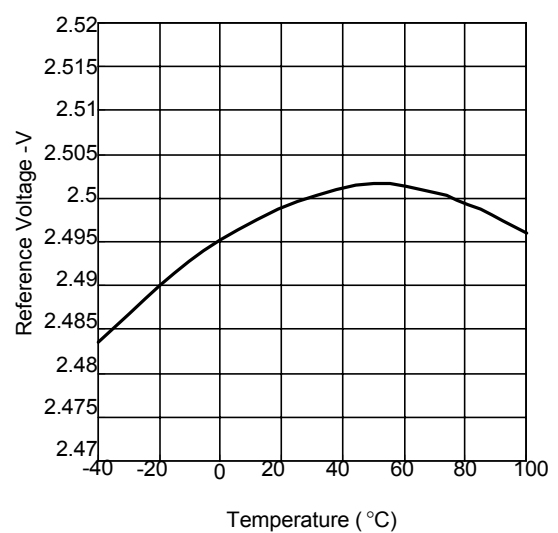

Typical Characteristics (Cont.)

Small-Signal Voltage Amplification vs Frequency

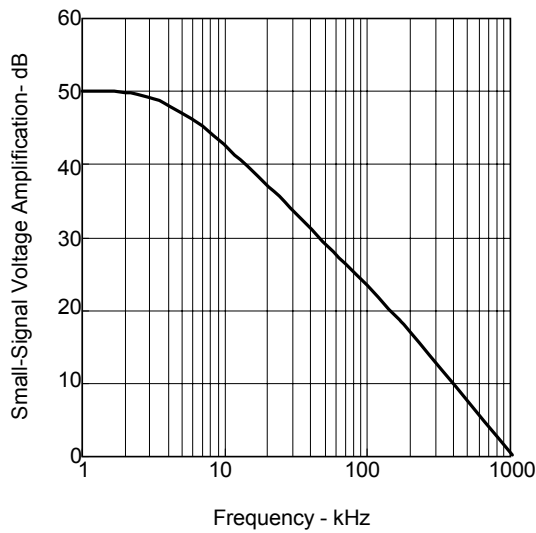

Pulse Response

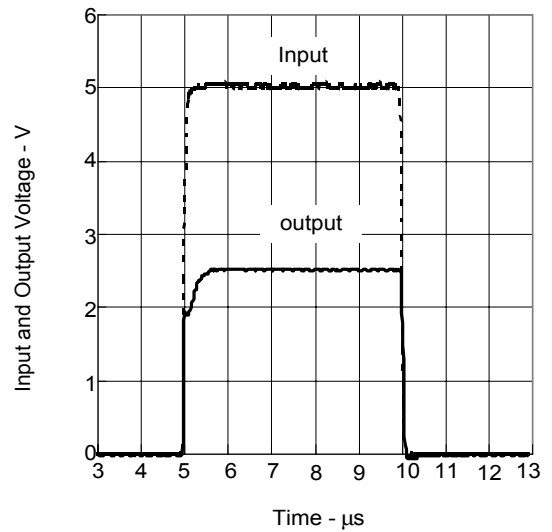

Off-State Cathode Current vs Temperature

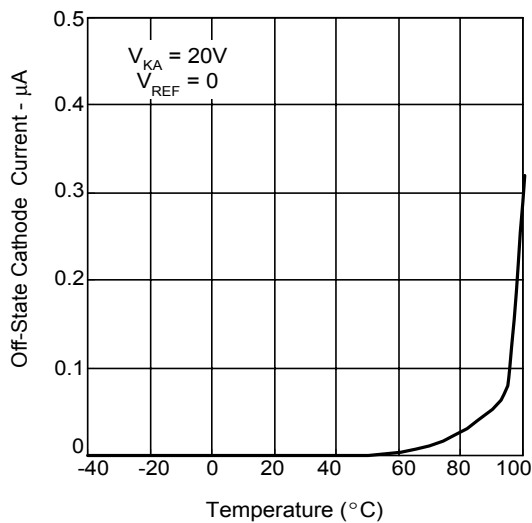

Ratio of Delta Reference Voltage to Delta Cathode Voltage vs Temperature

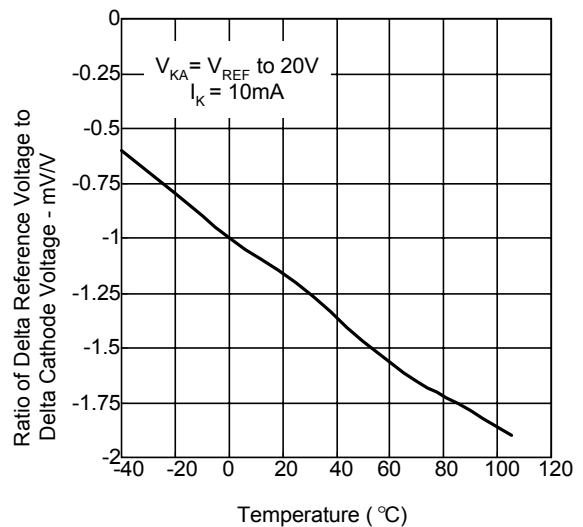

Typical Characteristics (Cont.)

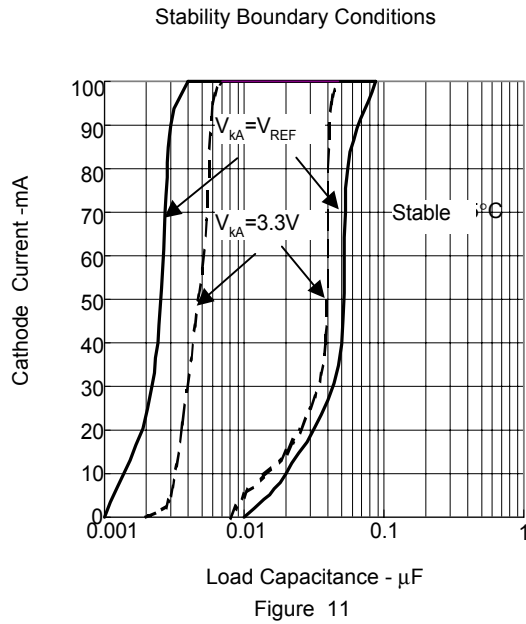
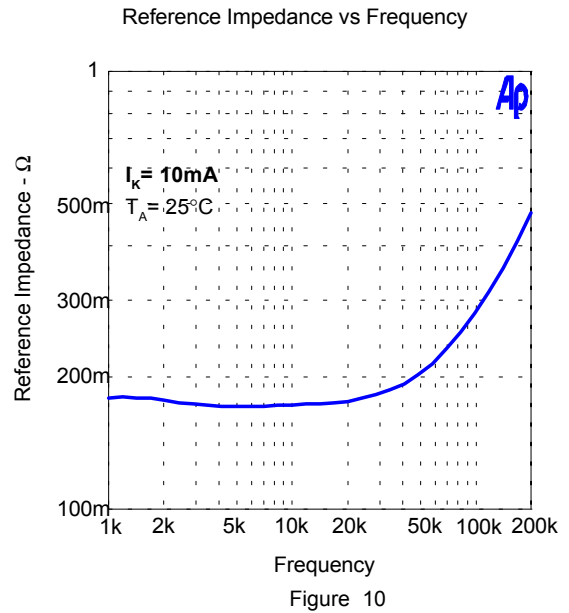
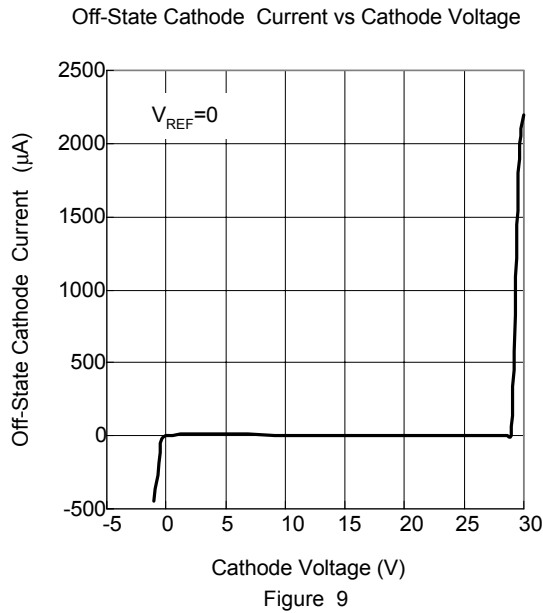

Packaging Information

SOT-23

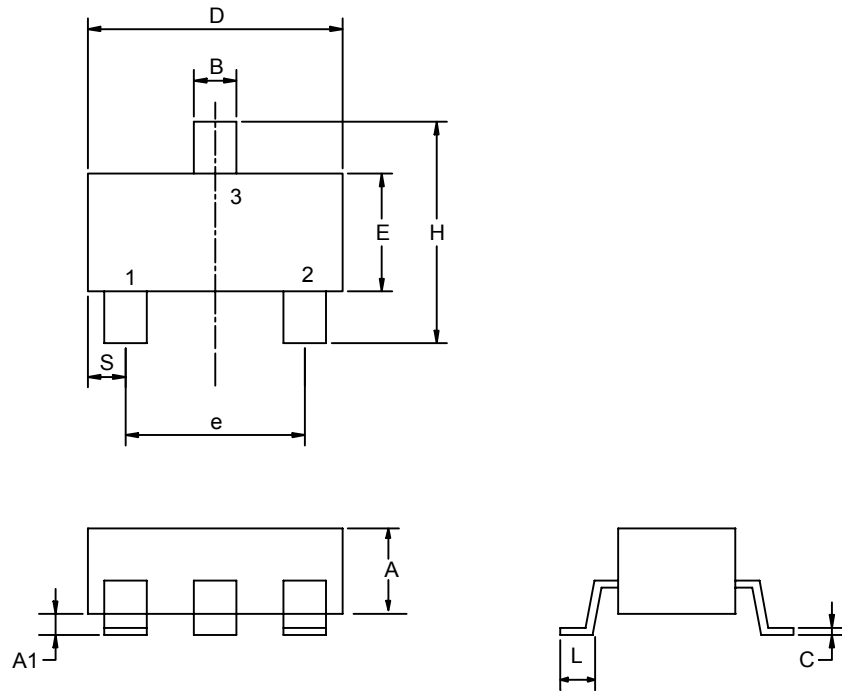

Dim	Millimeters		Inches	
	Min.	Max.	Min.	Max.
A	1.00	1.30	0.039	0.051
A1	0.00	0.10	0.000	0.004
B	0.35	0.51	0.014	0.020
C	0.10	0.25	0.004	0.010
D	2.70	3.10	0.106	0.122
E	1.40	1.80	0.055	0.071
e	1.90 BSC		0.075 BSC	
H	2.40	3.00	0.094	0.118
L	0.37		0.0015	

Packaging Information

SOT-89

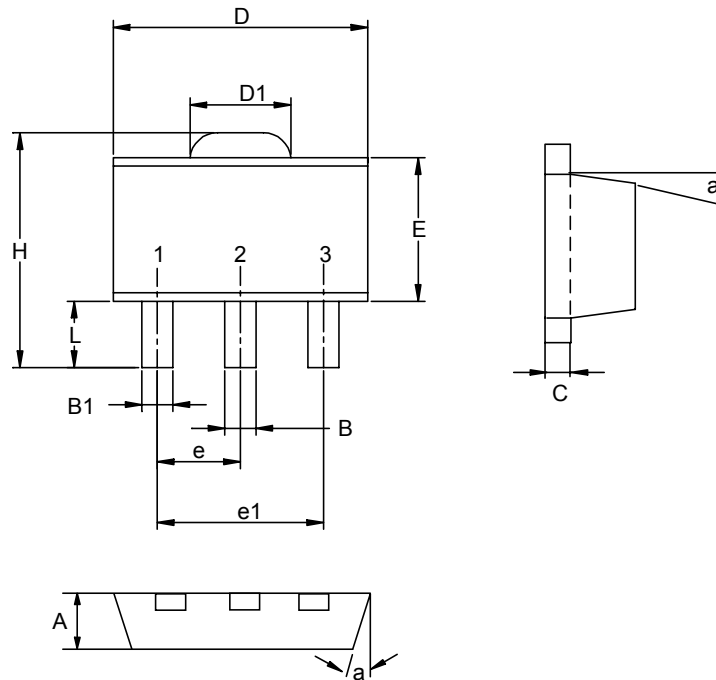

Dim	Millimeters		Inches	
	Min.	Max.	Min.	Max.
A	1.40	1.60	0.055	0.063
B	0.40	0.56	0.016	0.022
B1	0.35	0.48	0.014	0.019
C	0.35	0.44	0.014	0.017
D	4.40	4.60	0.173	0.181
D1	1.35	1.83	0.053	0.072
e	1.50 BSC		0.059 BSC	
e1	3.00 BSC		0.118 BSC	
E	2.29	2.60	0.090	0.102
H	3.75	4.25	0.148	0.167
L	0.80	1.20	0.031	0.047
α		10°		10°

Packaging Information

TO-92

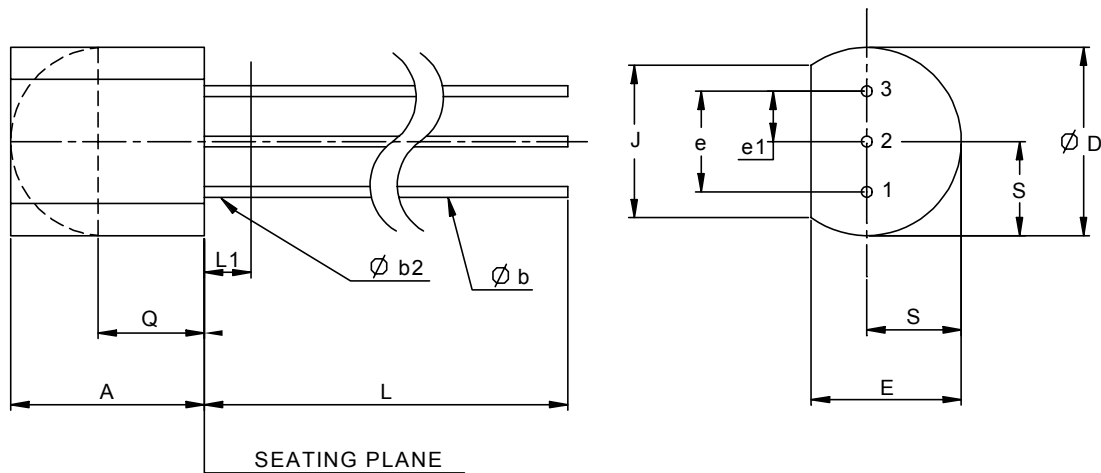

Dim	Millimeters		Inches	
	Min.	Max.	Min.	Max.
A	4.318	5.334	0.170	0.210
ϕb	0.406	0.559	0.016	0.022
$\phi b2$	0.406	0.559	0.016	0.022
ϕD	4.445	5.207	0.175	0.205
E	3.175	4.191	0.125	0.165
e	2.413	2.667	0.095	0.105
e1	1.143	1.397	0.045	0.055
J	3.429		0.135	
L	12.70		0.500	
L1		1.27		0.050
Q	2.921		0.115	
S	2.032	2.667	0.080	0.105

Physical Specifications

Terminal Material	Solder-Plated Copper (Solder Material : 90/10 or 63/37 SnPb)
Lead Solderability	Meets EIA Specification RSI86-91, ANSI/J-STD-002 Category 3.

Reflow Condition (IR/Convection or VPR Reflow)

Reference JEDEC Standard J-STD-020A APRIL 1999

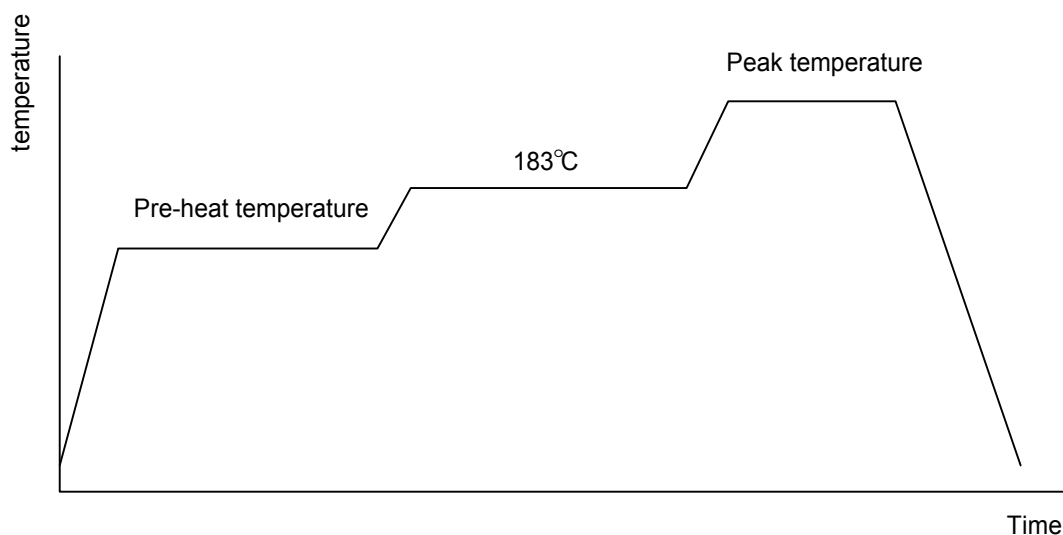

Classification Reflow Profiles

	Convection or IR/ Convection	VPR
Average ramp-up rate(183°C to Peak)	3°C/second max.	10 °C /second max.
Preheat temperature 125 ± 25°C)	120 seconds max	
Temperature maintained above 183°C	60 – 150 seconds	
Time within 5°C of actual peak temperature	10 –20 seconds	60 seconds
Peak temperature range	220 +5/-0°C or 235 +5/-0°C	215-219°C or 235 +5/-0°C
Ramp-down rate	6 °C /second max.	10 °C /second max.
Time 25°C to peak temperature	6 minutes max.	

Package Reflow Conditions

pkg. thickness ≥ 2.5mm and all bgas	pkg. thickness < 2.5mm and pkg. volume ≥ 350 mm ³	pkg. thickness < 2.5mm and pkg. volume < 350mm ³
Convection 220 +5/-0 °C		Convection 235 +5/-0 °C
VPR 215-219 °C		VPR 235 +5/-0 °C
IR/Convection 220 +5/-0 °C		IR/Convection 235 +5/-0 °C

Reliability test program

Test item	Method	Description
SOLDERABILITY	MIL-STD-883D-2003	245°C , 5 SEC
HOLT	MIL-STD-883D-1005.7	1000 Hrs Bias @ 125 °C
PCT	JESD-22-B, A102	168 Hrs, 100 % RH , 121°C
TST	MIL-STD-883D-1011.9	-65°C ~ 150°C, 200 Cycles
ESD	MIL-STD-883D-3015.7	VHBM > 2KV, VMM > 200V
Latch-Up	JESD 78	10ms , I _{tr} > 100mA

Carrier Tape & Reel Dimensions

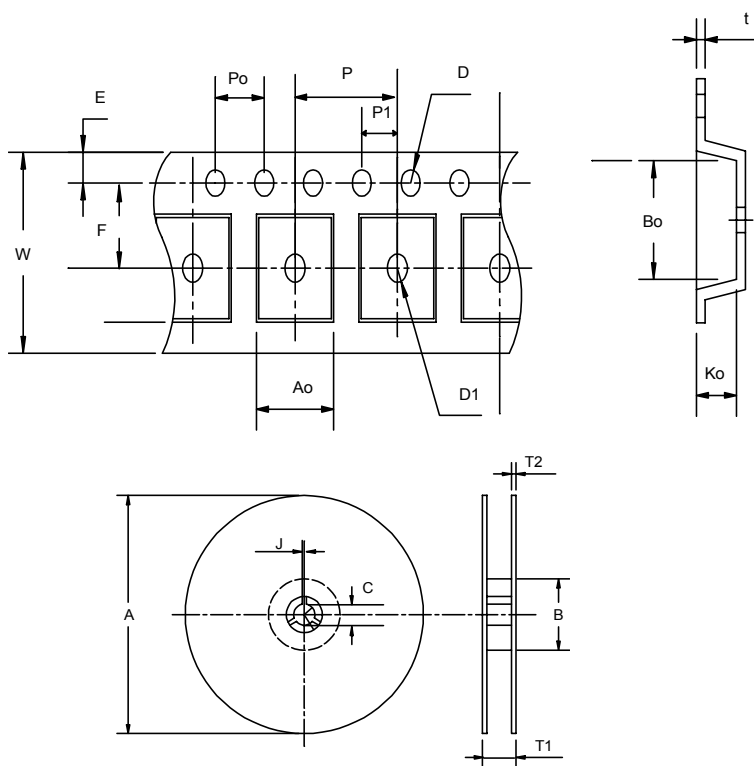

Application	A	B	C	J	T1	T2	W	P	E
SOT-23	178±1	60 ± 1.0	12.0	2.5 ± 0.15	9.0 ± 0.5	1.4	8.0 ^{+0.3} -0.3	4.0	1.75
	F	D	D1	Po	P1	Ao	Bo	Ko	t
	3.5 ± 0.05	1.5 +0.1	φ 0.1MIN	4.0	2.0 ± 0.05	3.1	3.0	1.3	0.2±0.03
Application	A	B	C	J	T1	T2	W	P	E
SOT-89	178 ±1	70 ± 2	13.5 ± 0.15	3 ± 0.15	14 ± 2	1.3 ± 0.3	12 ^{+0.3} 12 - 0.1	8 ± 0.1	1.75± 0.1
	F	D	D1	Po	P1	Ao	Bo	Ko	t
	5.5 ± 0.05	1.5± 0.1	1.5± 0.1	4.0 ± 0.1	2.0 ± 0.1	4.8 ± 0.1	4.5± 0.1	1.80± 0.1	0.3±0.013

(mm)

Carrier Tape & Reel Dimensions

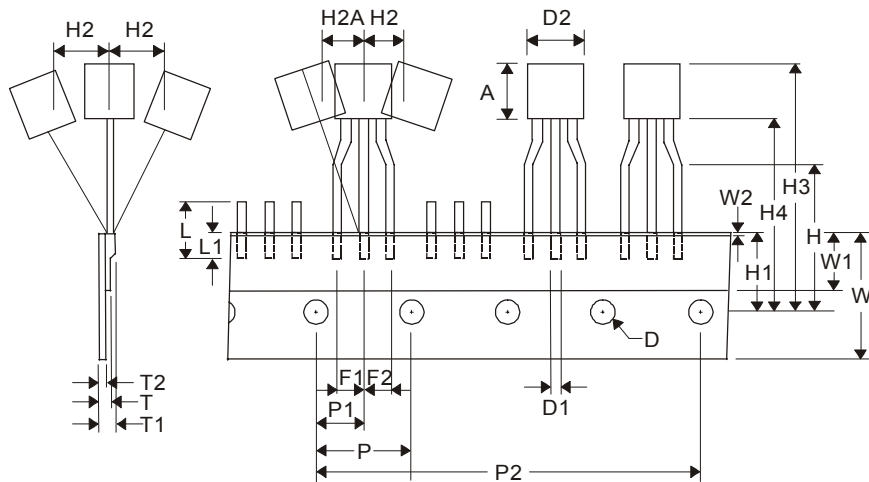

Application	A	D	D1	D2	F1,F2	H	H1	H2	H2A
TO-92	3.18~12	4.0±0.2	0.36~0.53	9.0 MAX	2.5+0.2 -0.1	16±0.5	9±0.5	0.5 MAX	0.5 MAX
	H3	H4	L	L1	P	P1	P2	T	T1
	27.0 MAX	20.0 MAX	11.0 MAX	2.5 MIN	12.7±0.2	6.35±0.4	50.8±0.5	0.55 MAX	1.42 MAX
	T2	W	W1	W2					
	0.36~0.68	17.5~19	5.0~7.0	0.5 MAX					

(mm)

Cover Tape Dimensions

Application	Carrier Width	Cover Tape Width	Devices Per Reel
SOT- 23	8	5.3	3000
SOT- 89	12	9.3	1000
TO-92	17.5~19	5.0~7.0	2000