

查询APT15D60K供应商

捷多邦, 专业PCB打样工厂, 24小时加急出货

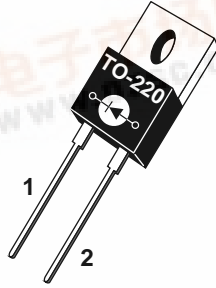

1 - Cathode  
2 - Anode  
Back of Case - Cathode



**ADVANCED  
POWER  
TECHNOLOGY®**  
**APT15D60K 600V 15A**

## ULTRAFAST SOFT RECOVERY RECTIFIER DIODE

### PRODUCT APPLICATIONS

- Anti-Parallel Diode
  - Switchmode Power Supply
  - Inverters
- Free Wheeling Diode
  - Motor Controllers
  - Converters
- Snubber Diode
- Uninterruptible Power Supply (UPS)
- Induction Heating
- High Speed Rectifiers

### PRODUCT FEATURES

- Ultrafast Recovery Times
- Soft Recovery Characteristics
- Popular TO-220 Package
- Low Forward Voltage
- High Blocking Voltage
- Low Leakage Current

### PRODUCT BENEFITS

- Low Losses
- Low Noise Switching
- Cooler Operation
- Higher Reliability Systems
- Increased System Power Density

### MAXIMUM RATINGS

All Ratings:  $T_C = 25^\circ\text{C}$  unless otherwise specified.

Symbol	Characteristic / Test Conditions	APT15D60K	UNIT
$V_R$	Maximum D.C. Reverse Voltage	600	Volts
$V_{RRM}$	Maximum Peak Repetitive Reverse Voltage		
$V_{RWM}$	Maximum Working Peak Reverse Voltage		
$I_F(AV)$	Maximum Average Forward Current ( $T_C = 90^\circ\text{C}$ , Duty Cycle = 0.5)	15	Amps
$I_F(RMS)$	RMS Forward Current	25	
$I_{FSM}$	Non-Repetitive Forward Surge Current ( $T_J = 45^\circ\text{C}$ , 8.3ms)	110	
$T_J, T_{STG}$	Operating and Storage Temperature Range	-55 to 150	$^\circ\text{C}$
$T_L$	Lead Temperature: 0.063" from Case for 10 Sec.	300	

### STATIC ELECTRICAL CHARACTERISTICS

Symbol	Characteristic / Test Conditions	MIN	TYP	MAX	UNIT
$V_F$	Maximum Forward Voltage			1.8	Volts
				$I_F = 15\text{A}$	
				$I_F = 30\text{A}$	
$I_{RM}$	Maximum Reverse Leakage Current			1.6	$\mu\text{A}$
				$I_F = 15\text{A}, T_J = 150^\circ\text{C}$	
				$V_R = V_R$ Rated	
$C_T$	Junction Capacitance, $V_R = 200\text{V}$			150	pF
				$V_R = V_R$ Rated, $T_J = 125^\circ\text{C}$	
$L_S$	Series Inductance (Lead to Lead 5mm from Base)		10		nH

APT Website - <http://www.advancedpower.com>

405 S.W. Columbia Street

Bend, Oregon 97702-1035

Phone: (541) 382-8028

FAX: (541) 388-0364

Avenue J.F. Kennedy, Bât B4 Parc Cadéra Nord

F-33700 Merignac - France

Phone: (33) 557 92 15 15

FAX: (33) 5 56 47 97 61

### DYNAMIC CHARACTERISTICS

APT15D60K

Symbol	Characteristic	MIN	TYP	MAX	UNIT
$t_{rr1}$	Reverse Recovery Time, $I_F = 1.0A$ , $di_F/dt = -15A/\mu s$ , $V_R = 30V$ , $T_J = 25^\circ C$		40	50	ns
$t_{rr2}$	Reverse Recovery Time		40		
$t_{rr3}$	$I_F = 15A$ , $di_F/dt = -100A/\mu s$ , $V_R = 350V$		80		
$t_{fr1}$	Forward Recovery Time		170		
$t_{fr2}$	$I_F = 15A$ , $di_F/dt = 100A/\mu s$ , $V_R = 350V$		170		
$I_{RRM1}$	Reverse Recovery Current		2.5	5	Amps
$I_{RRM2}$	$I_F = 15A$ , $di_F/dt = -100A/\mu s$ , $V_R = 350V$		3	6	
$Q_{rr1}$	Recovery Charge		50		nC
$Q_{rr2}$	$I_F = 15A$ , $di_F/dt = -100A/\mu s$ , $V_R = 350V$		120		
$V_{fr1}$	Forward Recovery Voltage		2.2		Volts
$V_{fr2}$	$I_F = 15A$ , $di_F/dt = 100A/\mu s$ , $V_R = 350V$		2.2		
diM/dt	Rate of Fall of Recovery Current		200		A/ $\mu s$
	$I_F = 15A$ , $di_F/dt = -100A/\mu s$ , $V_R = 350V$ (See Figure 10)		100		

### THERMAL AND MECHANICAL CHARACTERISTICS

Symbol	Characteristic / Test Conditions	MIN	TYP	MAX	UNIT
$R_{\theta JC}$	Junction-to-Case Thermal Resistance			2.0	$^\circ C/W$
$R_{\theta JA}$	Junction-to-Ambient Thermal Resistance			80	
$W_T$	Package Weight		0.07		oz
			1.9		gm
Torque	Maximum Mounting Torque (Screw Type = 6-32 or 3.5mm Machine)			6.4	lb•in
				0.7	N•m

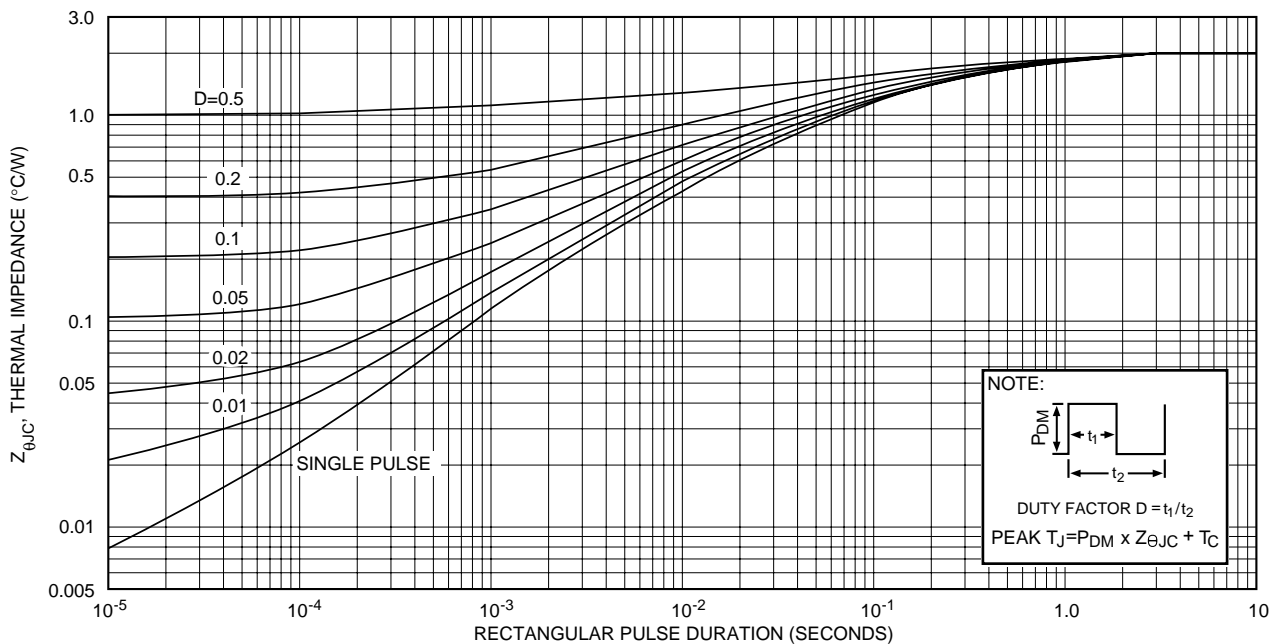

**APT15D60K**

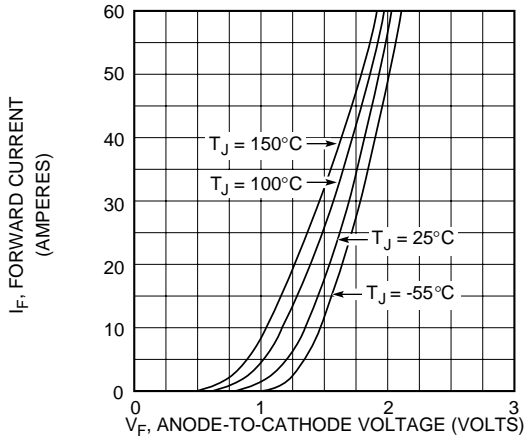

**Figure 2, Forward Voltage Drop vs Forward Current**

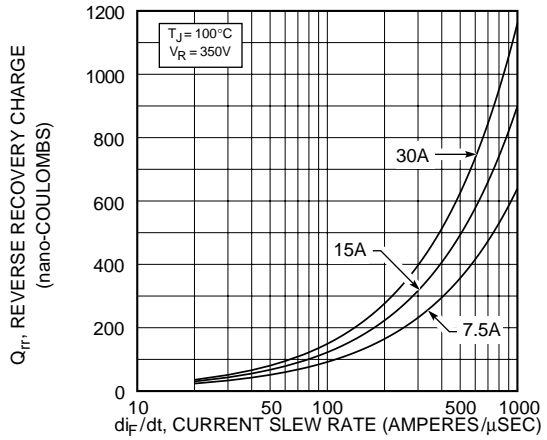

**Figure 3, Reverse Recovery Charge vs Current Slew Rate**

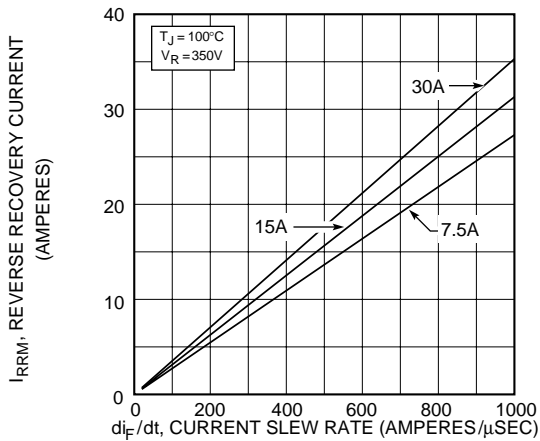

**Figure 4, Reverse Recovery Current vs Current Slew Rate**

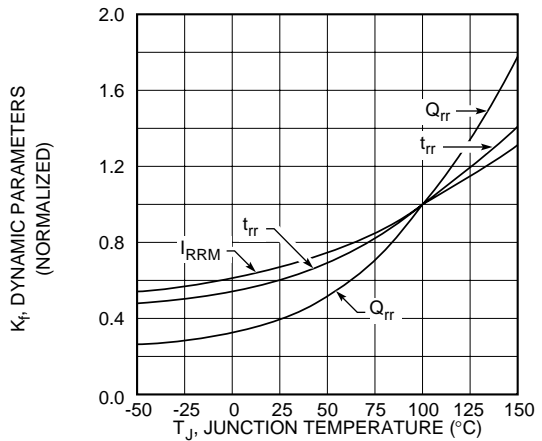

**Figure 5, Dynamic Parameters vs Junction Temperature**

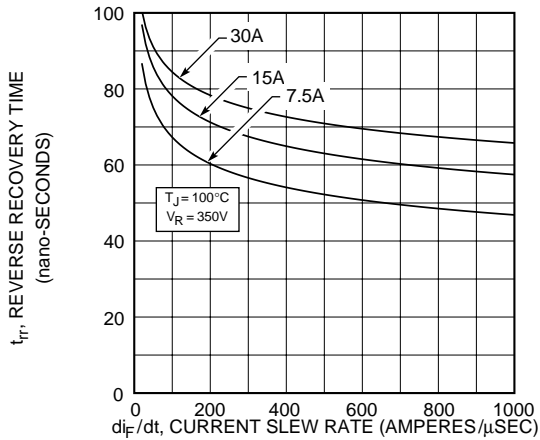

**Figure 6, Reverse Recovery Time vs Current Slew Rate**

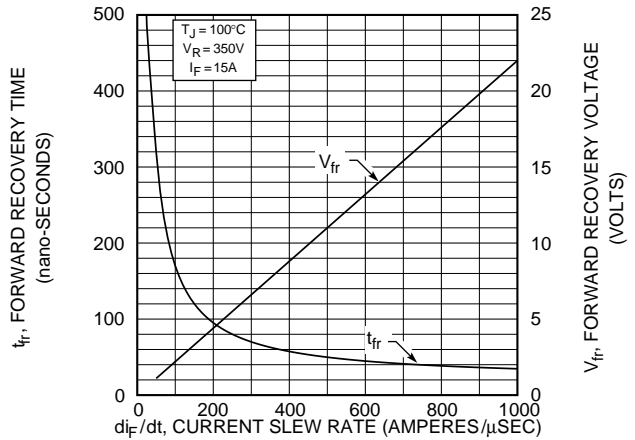

**Figure 7, Forward Recovery Voltage/Time vs Current Slew Rate**

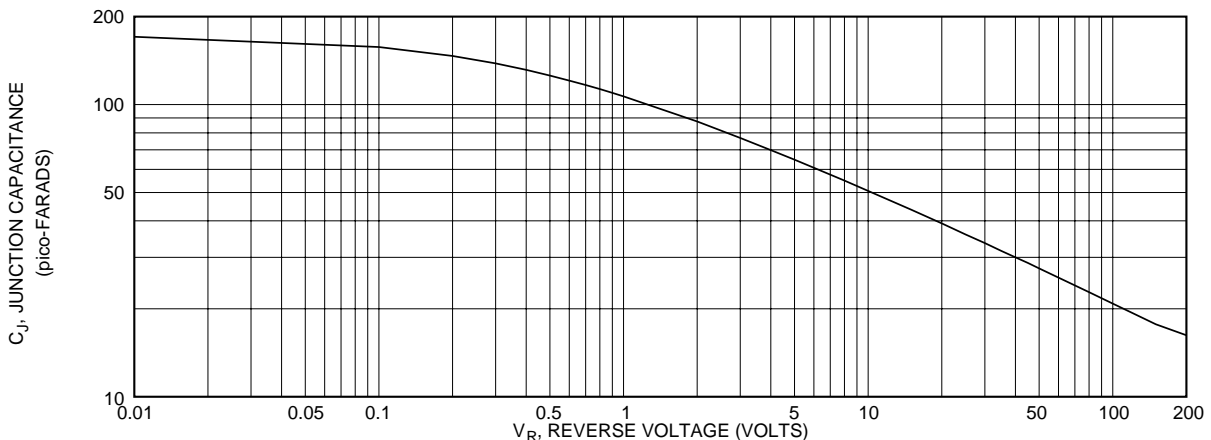

**Figure 8, Junction Capacitance vs Reverse Voltage**

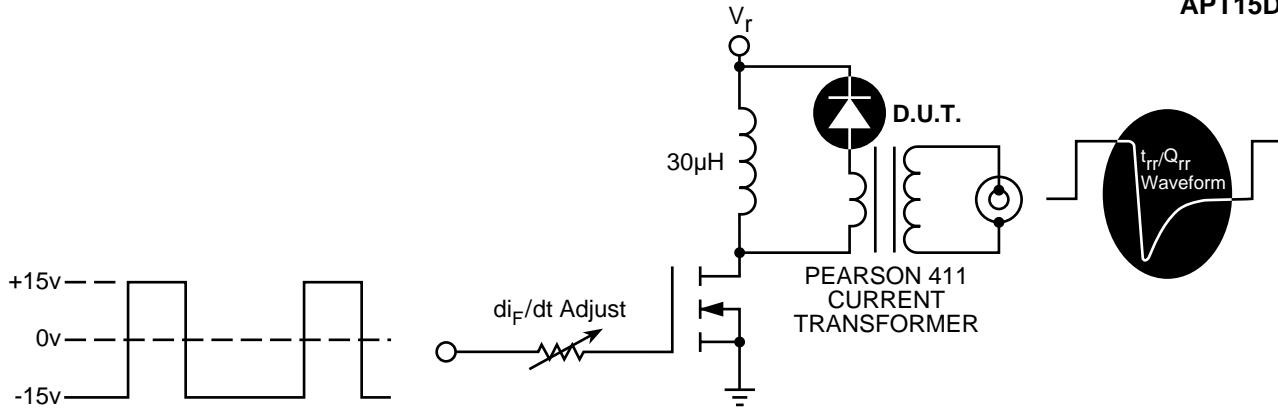

Figure 9, Diode Reverse Recovery Test Circuit and Waveforms

- 1  $I_F$  - Forward Conduction Current
- 2  $di_F/dt$  - Current Slew Rate, Rate of Forward Current Change Through Zero Crossing.
- 3  $I_{RRM}$  - Peak Reverse Recovery Current.
- 4  $t_{rr}$  - Reverse Recovery Time Measured from Point of  $I_F$  Current Falling Through Zero to a Tangent Line {6  $diM/dt$ } Extrapolated Through Zero Defined by 0.75 and 0.50  $I_{RRM}$ .
- 5  $Q_{rr}$  - Area Under the Curve Defined by  $I_{RRM}$  and  $t_{rr}$ .
- 6  $diM/dt$  - Maximum Rate of Current Change During the Trailing Portion of  $t_{rr}$ .

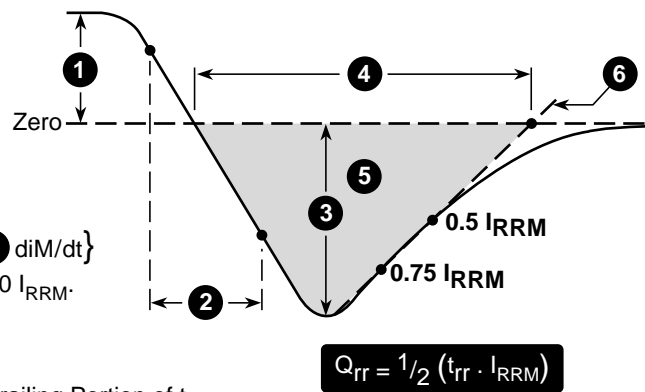
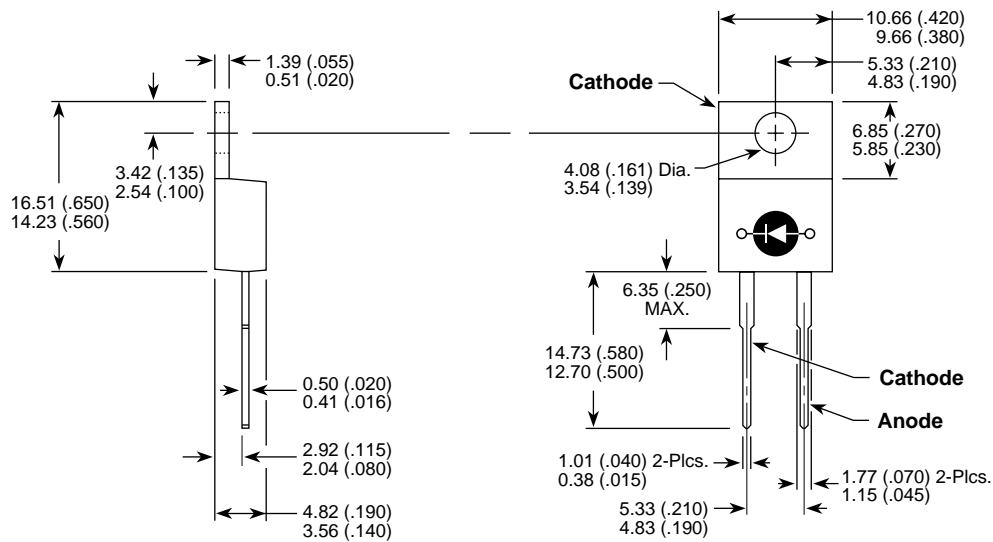

Figure 10, Diode Reverse Recovery Waveform and Definitions

APT Reserves the right to change, without notice, the specifications and information contained herein.

TO-220AB Package Outline



Dimensions in Millimeters and (Inches)