



Certificate Number: Q#0561

Certificate Number: E17276

AR3500 - AR3512

AUTOMOTIVE RECTIFIER DIODES

PRV : 50 - 1200 Volts
Io : 35 Amperes

FEATURES :

- * High current capability
- * High surge current capability
- * High reliability
- * Low reverse current
- * Low forward voltage drop

MECHANICAL DATA :

- * Case : Molded plastic
- * Epoxy : UL94V-O rate flame retardant
- * Terminals : Terminal are readily solderable
- * Polarity : Cathode polarity band
- * Mounting position : Any
- * Weight : 1.84 grams

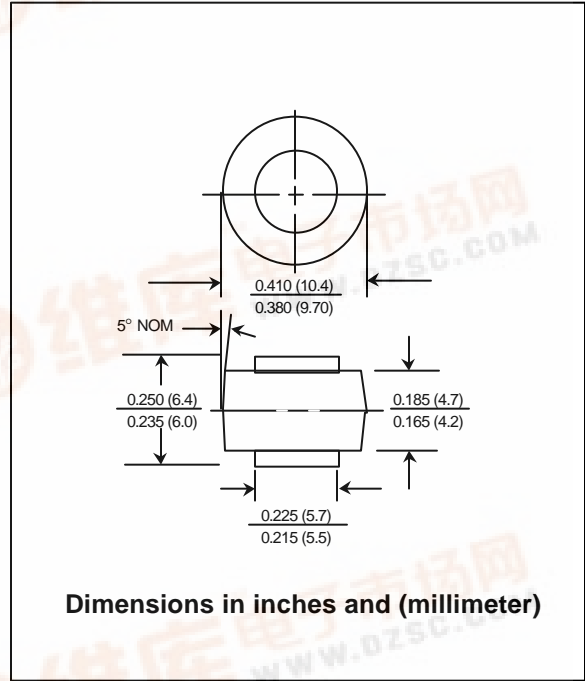

MAXIMUM RATINGS AND ELECTRICAL CHARACTERISTICS

Rating at 25 °C ambient temperature unless otherwise specified.
 Single phase, half wave, 60 Hz, resistive or inductive load.
 For capacitive load, derate current by 20%.

RATING	SYMBOL	AR 3500	AR 3501	AR 3502	AR 3504	AR 3506	AR 3508	AR 3510	MR 2512	UNIT
Maximum Repetitive Peak Reverse Voltage	V_{RRM}	50	100	200	400	600	800	1000	1200	Volts
Maximum RMS Voltage	V_{RMS}	35	70	140	280	420	560	700	840	Volts
Maximum DC Blocking Voltage	V_{DC}	50	100	200	400	600	800	1000	1200	Volts
Average Rectified Forward Current $T_c = 150^\circ C$	$I_{F(AV)}$	35								Amps.
Peak Forward Surge Current Single half sine wave superimposed on rated load (JEDEC Method)	I_{FSM}	400								Amps.
Maximum Forward Voltage at $I_F = 35$ Amps.	V_F	1.1								Volts
Maximum DC Reverse Current $T_a = 25^\circ C$ at rated DC Blocking Voltage $T_a = 100^\circ C$	I_R	5.0								μA
	$I_{R(H)}$	1.0								mA
Thermal Resistance (Note 1)	$R_{\theta JC}$	1.0								$^\circ C/W$
Junction Temperature Range	T_J	- 65 to + 175								$^\circ C$
Storage Temperature Range	T_{STG}	- 65 to + 175								$^\circ C$
Marking Code										





Certificate Number: QI0561

Certificate Number: E17276

RATING AND CHARACTERISTIC CURVES (AR3500 - AR3512)

FIG.1 - DERATING CURVE FOR OUTPUT RECTIFIED CURRENT

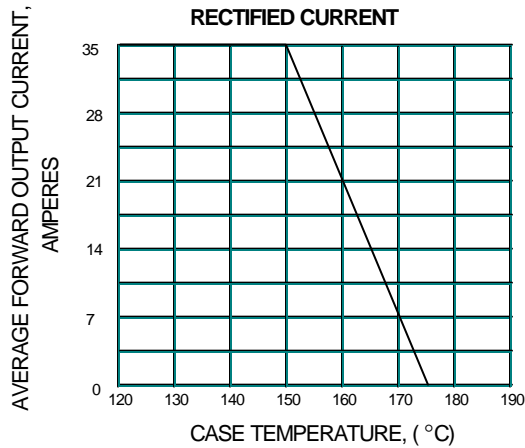

FIG.2 - MAXIMUM NON-REPETITIVE PEAK FORWARD SURGE CURRENT

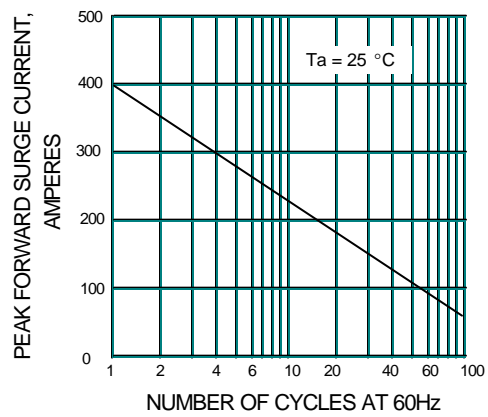

FIG.3 - TYPICAL FORWARD CHARACTERISTICS

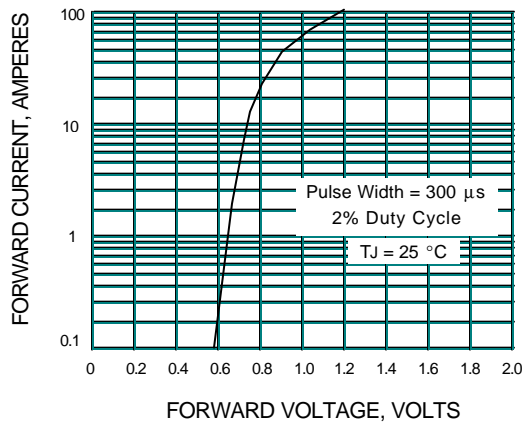

FIG.4 - TYPICAL REVERSE CHARACTERISTICS

