

ARF446
ARF447

Common Source

RF POWER MOSFETs
N-CHANNEL ENHANCEMENT MODE

250V 250W 65MHz

The ARF446 and ARF447 comprise a symmetric pair of common source RF power transistors designed for push-pull scientific, commercial, medical and industrial RF power amplifier applications up to 65 MHz.

- **Specified 250 Volt, 40.68 MHz Characteristics:**
 - Output Power = 250 Watts.
 - Gain = 15dB (Class C)
 - Efficiency = 75%
- **Low Cost Common Source RF Package.**
- **Very High Breakdown for Improved Ruggedness.**
- **Low Thermal Resistance.**
- **Nitride Passivated Die for Improved Reliability.**

MAXIMUM RATINGS

All Ratings: $T_C = 25^\circ\text{C}$ unless otherwise specified.

Symbol	Parameter	ARF446/447	UNIT
V_{DSS}	Drain-Source Voltage	900	Volts
V_{DGO}	Drain-Gate Voltage	900	
I_D	Continuous Drain Current @ $T_C = 25^\circ\text{C}$	6.5	Amps
V_{GS}	Gate-Source Voltage	± 30	Volts
P_D	Total Power Dissipation @ $T_C = 25^\circ\text{C}$	230	Watts
$R_{\theta JC}$	Junction to Case	0.55	$^\circ\text{C}/\text{W}$
T_J, T_{STG}	Operating and Storage Junction Temperature Range	-55 to 150	$^\circ\text{C}$
T_L	Lead Temperature: 0.063" from Case for 10 Sec.	300	

STATIC ELECTRICAL CHARACTERISTICS

Symbol	Characteristic / Test Conditions	MIN	TYP	MAX	UNIT
BV_{DSS}	Drain-Source Breakdown Voltage ($V_{GS} = 0\text{V}, I_D = 250 \mu\text{A}$)	900			Volts
$V_{DS(ON)}$	On State Drain Voltage ^① ($I_D(ON) = 3.5\text{A}, V_{GS} = 10\text{V}$)			7	
I_{DSS}	Zero Gate Voltage Drain Current ($V_{DS} = V_{DSS}, V_{GS} = 0\text{V}$)			25	μA
	Zero Gate Voltage Drain Current ($V_{DS} = 0.8 V_{DSS}, V_{GS} = 0\text{V}, T_C = 125^\circ\text{C}$)			250	
I_{GSS}	Gate-Source Leakage Current ($V_{GS} = \pm 30\text{V}, V_{DS} = 0\text{V}$)			± 100	nA
g_{fs}	Forward Transconductance ($V_{DS} = 25\text{V}, I_D = 3.5\text{A}$)	4	5.7		mhos
$V_{GS(TH)}$	Gate Threshold Voltage ($V_{DS} = V_{GS}, I_D = 50\text{mA}$)	2		5	Volts

CAUTION: These Devices are Sensitive to Electrostatic Discharge. Proper Handling Procedures Should Be Followed.



DYNAMIC CHARACTERISTICS

ARF446/447

Symbol	Characteristic	Test Conditions	MIN	TYP	MAX	UNIT
C_{iss}	Input Capacitance	$V_{GS} = 0V$ $V_{DS} = 300V$ $f = 1\text{ MHz}$		1500	1800	pF
C_{oss}	Output Capacitance			70	130	
C_{rss}	Reverse Transfer Capacitance			27	50	
$t_{d(on)}$	Turn-on Delay Time	$V_{GS} = 15V$ $V_{DD} = 0.5 V_{DSS}$ $I_D = I_{D[Cont.]} @ 25^\circ C$ $R_G = 1.6\Omega$		7	15	ns
t_r	Rise Time			5	10	
$t_{d(off)}$	Turn-off Delay Time			23	40	
t_f	Fall Time			12	25	

FUNCTIONAL CHARACTERISTICS

Symbol	Characteristic	Test Conditions	MIN	TYP	MAX	UNIT
G_{PS}	Common Source Amplifier Power Gain	$f = 27.12\text{ MHz}$ $V_{GS} = 0V$ $V_{DD} = 300V$ $P_{out} = 250W$		20		dB
η	Drain Efficiency				80	%
ψ	Electrical Ruggedness VSWR 20:1			No Degradation in Output Power		
G_{PS}	Common Source Amplifier Power Gain	$f = 40.68\text{ MHz}$ $V_{GS} = 0V$ $V_{DD} = 250V$ $P_{out} = 250W$	13	15		dB
η	Drain Efficiency		70	75		%
ψ	Electrical Ruggedness VSWR 20:1		No Degradation in Output Power			

① Pulse Test: Pulse width < 380 μ s, Duty Cycle < 2%

APT Reserves the right to change, without notice, the specifications and information contained herein.

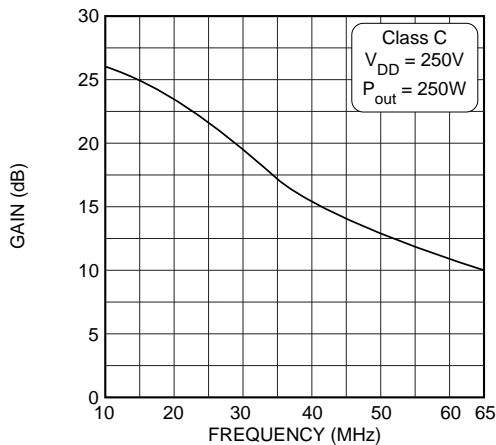

Figure 1, Typical Gain vs Frequency

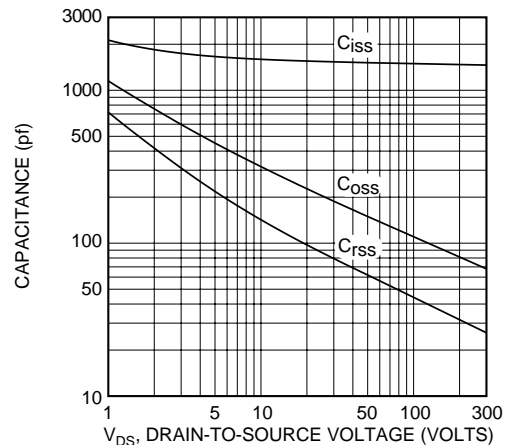
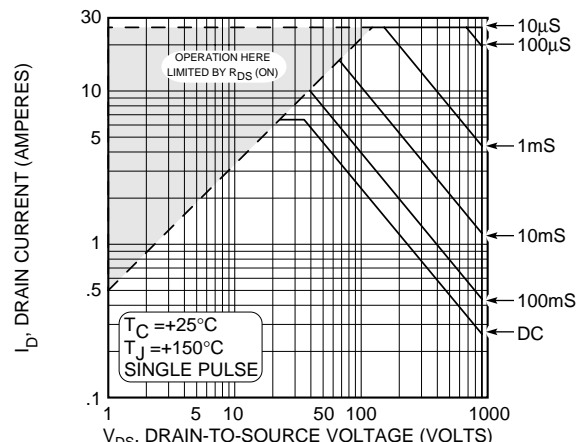
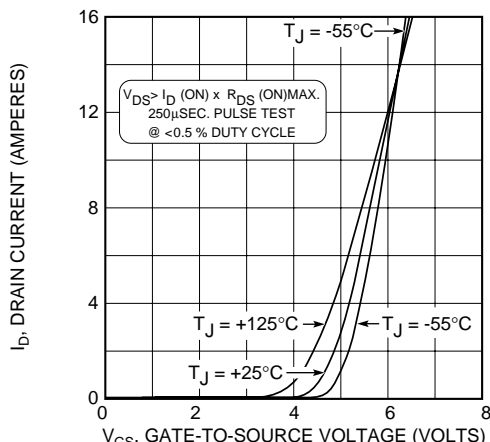

Figure 2, Typical Capacitance vs. Drain-to-Source Voltage



ARF446/447

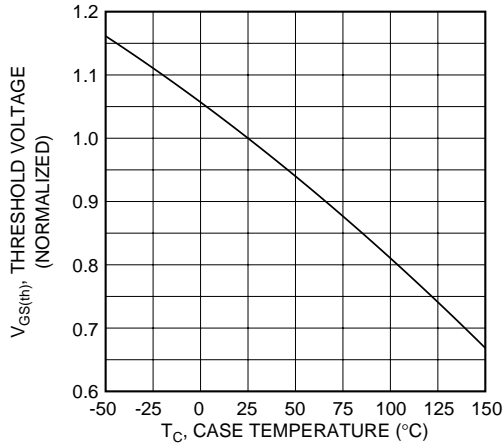

Figure 5, Typical Threshold Voltage vs Temperature

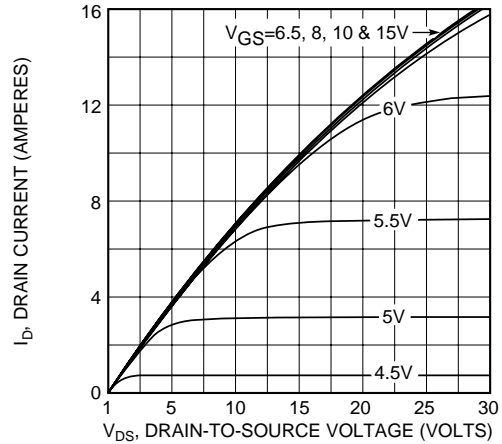

Figure 6, Typical Output Characteristics

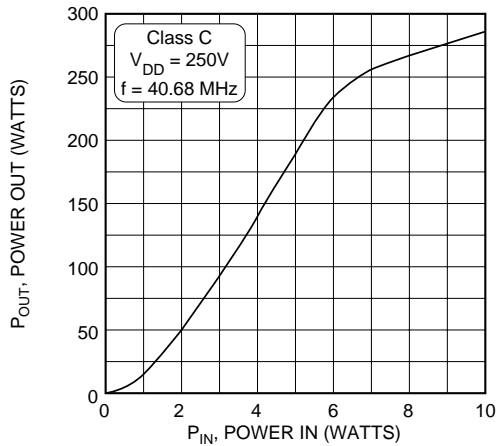

Figure 7, Typical Power Out vs Power In

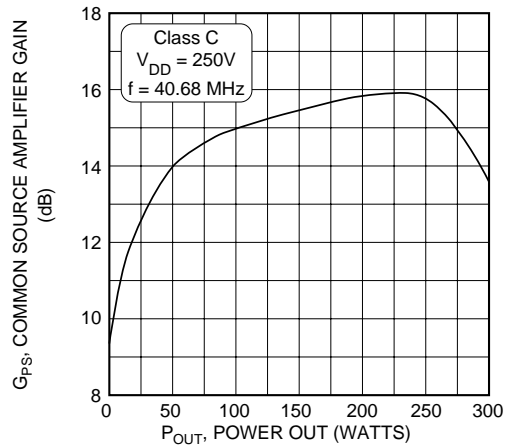

Figure 8, Typical Common Source Amplifier Gain vs Power Out

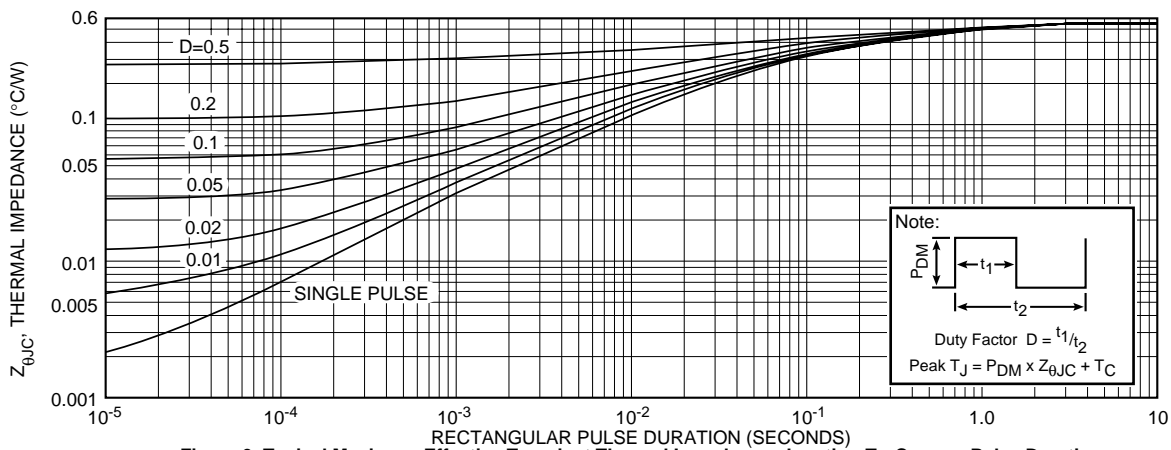

Figure 9, Typical Maximum Effective Transient Thermal Impedance, Junction-To-Case vs Pulse Duration

Table 1 - Typical Class C Large Signal Input-Output Impedance

Freq. (MHz)	Z _{in} (Ω)	Z _{oL} (Ω)
2.0	20.40 - j 9.6	142.0 - j 20
13.5	2.10 - j 6.4	73.0 - j 71
27.0	0.50 - j 2.3	30.0 - j 57
40.0	0.30 - j 0.4	15.0 - j 42
65.0	0.46 + j 2.0	6.2 - j 25

Z_{in} - gate shunted by 25Ω

Z_{oL} - load impedance of output matching network for 250W at 250V

40.68 MHz Test Circuit

Parts List

- C1-C3 -- Arco 465 or equivalent
- C4-C6 -- 1nF 500V COG chip
- L1 -- 2t #18 AWG .25" ID
- L2 -- 3t #18 AWG .25" ID
- L3 -- 8t #18 AWG .25" ID
- L4 -- VK200-4B ferrite choke 3uH
- R1 -- 25 Ohm 1/2W Carbon
- T1 -- 4:1 Broadband Transformer

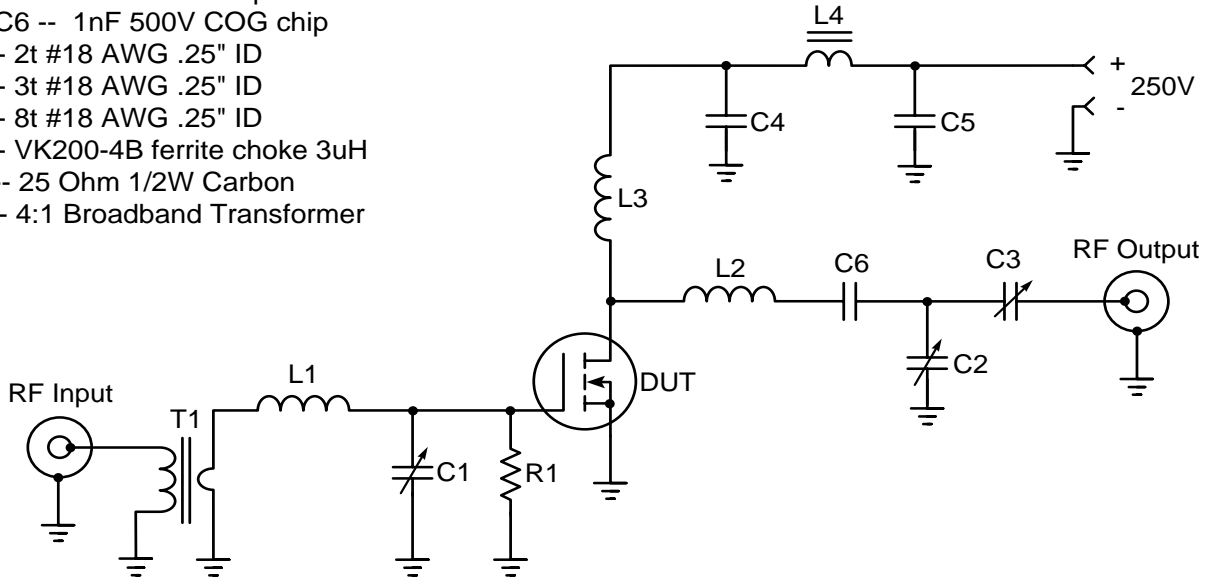

TO-247 Package Outline

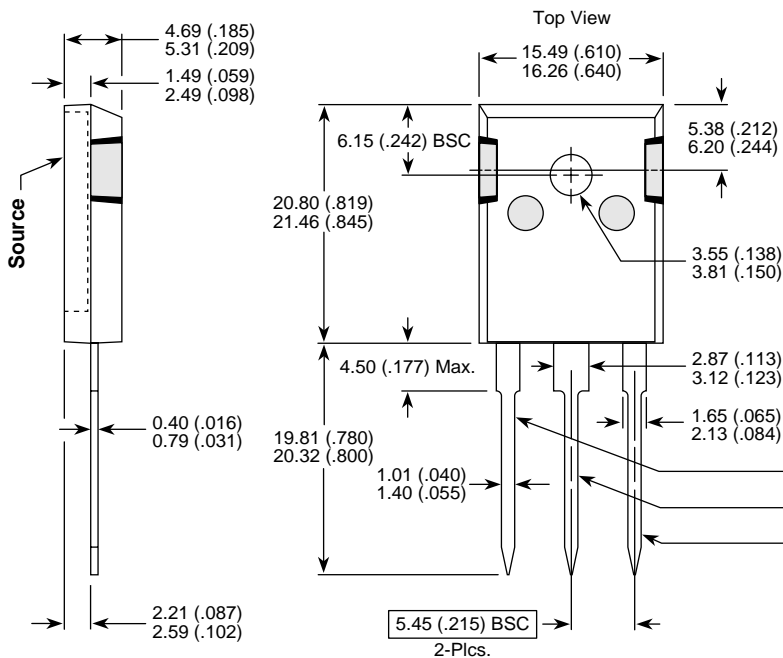

Dimensions in Millimeters and (Inches)

NOTE: The ARF446 and ARF447 comprise a symmetric pair of RF power transistors and meet the same electrical specifications. The device pin-outs are the mirror image of each other to allow ease of use as a push-pull pair.

Device	
ARF446	ARF447

Gate ——— Drain
 Source ——— Source
 Drain ——— Gate