

# GaAs IC High Isolation Positive Control SPDT Switch DC–3.0 GHz



AS177-86

## Features

- Positive Voltage Control (0/+3, +5 V)
- High Isolation (50 dB @ 0.9, 1.9 GHz)
- Low DC Power Consumption
- Ideal for GSM, PCS, 3G and ISM 2.4 GHz Applications
- Miniature Low Cost MSOP-10 Plastic Package

## Description

The AS177-86 is a GaAs FET IC SPDT switch packaged in a MSOP-10 plastic package for low cost, high isolation commercial applications. Ideal building block for base station dual band applications where synthesizer isolation is critical. Use in conjunction with the AS165-59 SPST switch to meet GSM synthesizer isolation requirements.

## MSOP-10

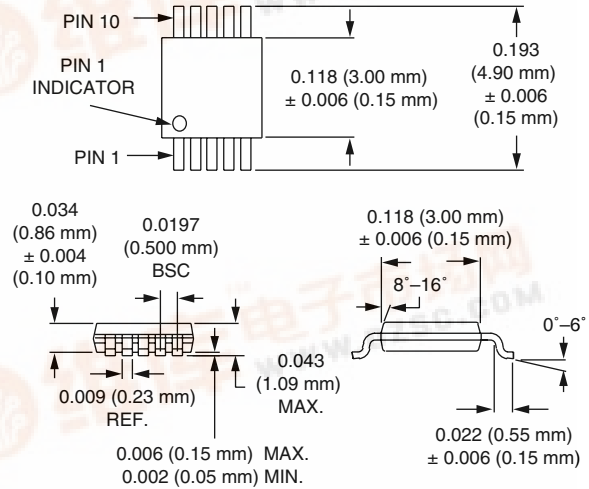

## Electrical Specifications at 25°C (0, +3 V), (0, +5 V)

Parameter <sup>1</sup>	Condition	Frequency <sup>2</sup>	Min.	Typ.	Max.	Unit
Insertion Loss <sup>3</sup>		DC–1.0 GHz		0.7	0.85	dB
		1.0–2.0 GHz		0.8	1.00	dB
		2.0–3.0 GHz		0.9	1.20	dB
Isolation	J <sub>1</sub> –J <sub>2</sub> /J <sub>1</sub> –J <sub>3</sub> J <sub>1</sub> –J <sub>2</sub> /J <sub>1</sub> –J <sub>3</sub>	DC–2.0 GHz	44/50	48/55		dB
		2.0–2.5 GHz	41/44	46/50		dB
		2.5–3.0 GHz	34	40		
VSWR <sup>4</sup>		DC–3.0 GHz		1.3:1	1.5:1	

## Operating Characteristics at 25°C (0, +5 V)

Parameter	Condition	Frequency	Min.	Typ.	Max.	Unit
Switching Characteristics <sup>5</sup>	Rise, Fall (10/90% or 90/10% RF) On, Off (50% CTL to 90/10% RF) Video Feedthru			50		ns
				100		ns
				25		mV
Input Power for 1 dB Compression	+3 V +5 V	0.5–3.0 GHz		+21		dB
		0.5–3.0 GHz		+27		dB
Intermodulation Intercept Point (IP3)	Two-tone Input Power +5 dBm +3 V +5 V	0.5–3.0 GHz		+41		dBm
		0.5–3.0 GHz		+45		dBm
Control Voltages	V <sub>Low</sub> = 0 to 0.2 V @ 20 μA Max. V <sub>High</sub> = +3 V @ 100 μA Max. to +5 V @ 200 μA Max. V <sub>S</sub> = V <sub>High</sub> ± 0.2 V					

1. All measurements made in a 50 Ω system, unless otherwise specified.  
 2. DC = 300 kHz.  
 3. Insertion loss changes by 0.003 dB/°C.  
 4. Insertion loss state.  
 5. Video feedthru measured with 1 ns risetime pulse and 500 MHz bandwidth.

### Typical Performance Data (0, +5 V)

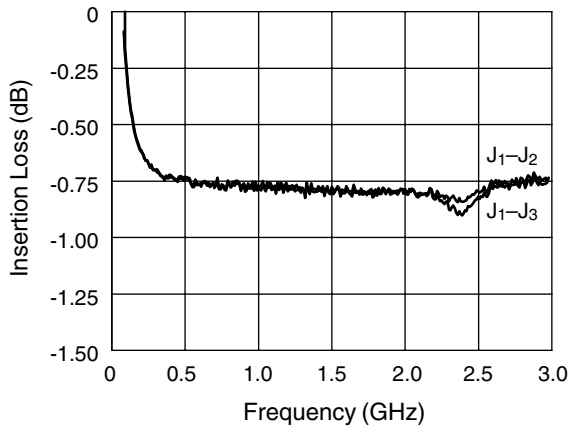

Insertion Loss vs. Frequency

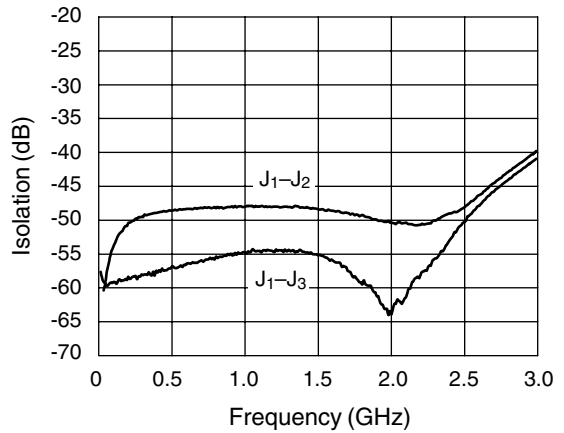

Isolation vs. Frequency

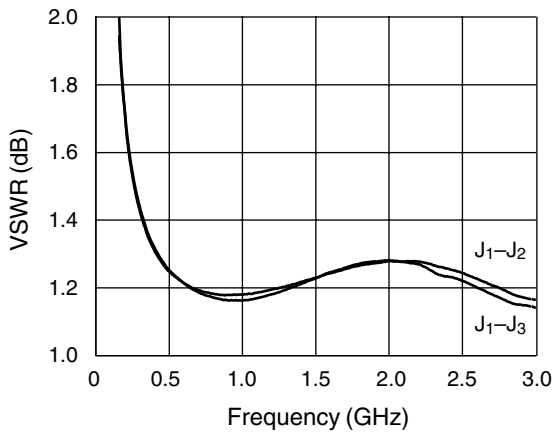

VSWR vs. Frequency

### Absolute Maximum Ratings

Characteristic	Value
RF Input Power	1 W Max. > 500 MHz 0/+8 V Control
Supply Voltage	+8 V
Control Voltage	-0.2 V, +8 V
Operating Temperature	-40°C to +85°C
Storage Temperature	-65°C to +150°C
$\theta_{JC}$	25°C/W

### Pin Out

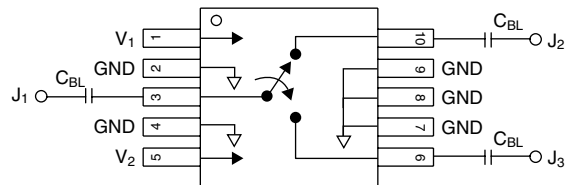

$C_{BL} = 47 \text{ pF}$  for operation >500MHz.

### Truth Table

$V_1$	$V_2$	$J_1-J_2$	$J_1-J_3$
0	$V_{High}$	Isolation	Insertion Loss
$V_{High}$	0	Insertion Loss	Isolation

$V_{High} = +3 \text{ V to } +5 \text{ V.}$