



Austin Semiconductor, Inc.

# SRAM AS5C512K8

## 512K x 8 SRAM

HIGH SPEED SRAM with  
REVOLUTIONARY PINOUT

### AVAILABLE AS MILITARY SPECIFICATIONS

- SMD 5962-95600
- SMD 5962-95613
- MIL-STD-883

### FEATURES

- Ultra High Speed Asynchronous Operation
- Fully Static, No Clocks
- Multiple center power and ground pins for improved noise immunity
- Easy memory expansion with CE\ and OE\ options
- All inputs and outputs are TTL-compatible
- Single +5V Power Supply +/- 10%
- Data Retention Functionality Testing (Contact Factory)
- Cost Efficient Plastic Packaging
- Extended Testing Over -55°C to +125°C for plastics
- Plastic 36 pin SOJ is fully compatible with the Ceramic 36 pin SOJ
- 3.3V Future Offering

### OPTIONS

- Timing
 

15ns access	-15
17ns access	-17
20ns access	-20
25ns access	-25
35ns access	-35
45ns access	-45
- Operating Temperature Ranges
 

Military (-55°C to +125°C)	XT
Industrial (-40°C to +85°C)	IT
- Package(s)
 

Ceramic LCC	EC	No. 210
Ceramic Flatpack	F	No. 307
Plastic SOJ	DJ	No. 903
Ceramic SOJ	ECJ	No.503
- 2V data retention/low power L (Consult Factory)
- Radiation Tolerant (EPI) E

### MARKING

### PIN ASSIGNMENT (Top View)

36-Pin SOJ (DJ & ECJ)  
36-Pin CLCC (EC)

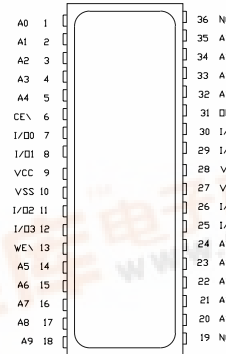

### 36-Pin Flat Pack (F)

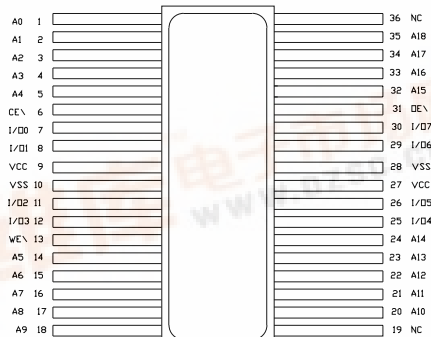

### GENERAL DESCRIPTION

The AS5C512K8 is a high speed SRAM. It offers flexibility in high-speed memory applications, with chip enable (CE\ ) and output enable (OE\ ) capabilities. These features can place the outputs in High-Z for additional flexibility in system design.

Writing to these devices is accomplished when write enable (WE\ ) and CE\ inputs are both LOW. Reading is accomplished when WE\ remains HIGH and CE\ and OE\ go LOW.

As a option, the device can be supplied offering a reduced power standby mode, allowing system designers to meet low standby power requirements. This device operates from a single +5V power supply and all inputs and outputs are fully TTL-compatible.

The AS5C512K8DJ offers the convenience and reliability of the AS5C512K8 SRAM and has the cost advantage of a durable plastic. The AS5C512K8DJ is footprint compatible with 36 pin CSOJ package of the SMD 5692-95600.

For more products and information  
please visit our web site at



[www.austinsemiconductor.com](http://www.austinsemiconductor.com)



Austin Semiconductor, Inc.

# SRAM AS5C512K8

## FUNCTIONAL BLOCK DIAGRAM

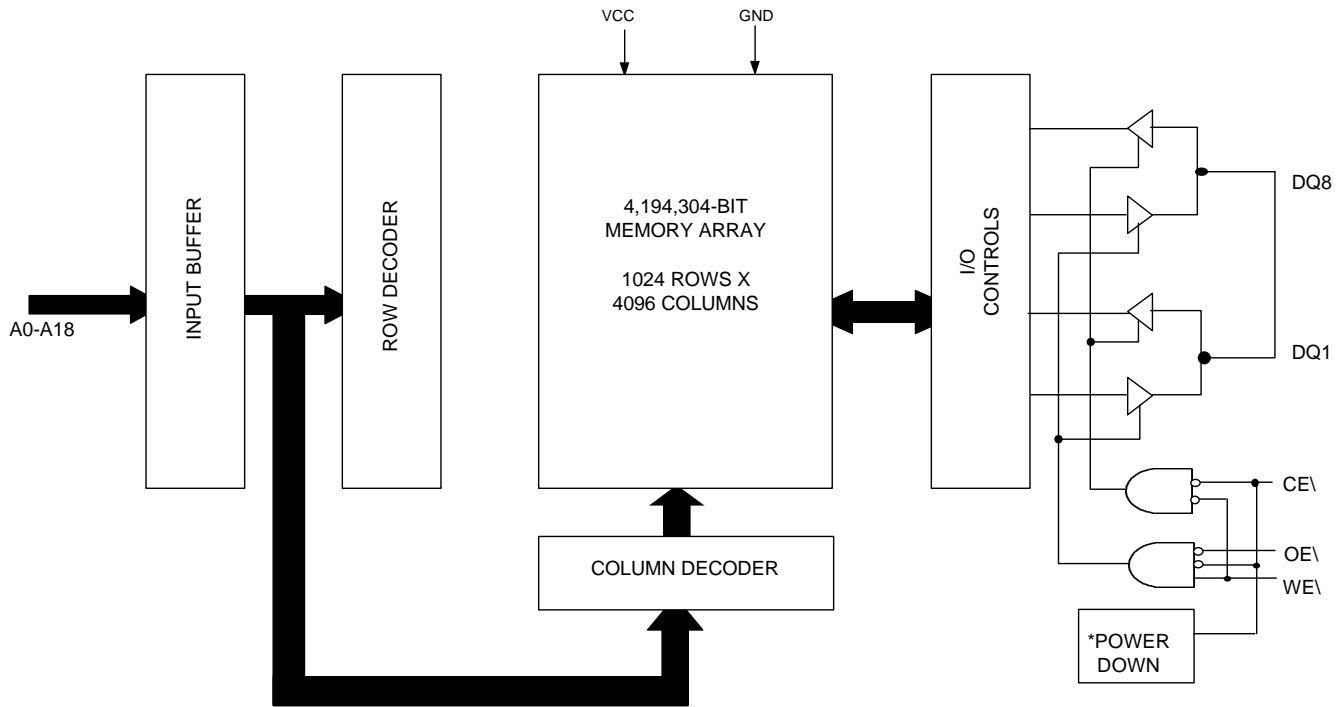

*\*On the low voltage Data Retention option.*

### TRUTH TABLE

MODE	OE\	CE\	WE\	I/O	POWER
STANDBY	X	H	X	HIGH-Z	STANDBY
READ	L	L	H	Q	ACTIVE
NOT SELECTED	H	L	H	HIGH-Z	ACTIVE
WRITE	X	L	L	D	ACTIVE

X = Don't Care

### PIN FUNCTIONS

A0 - A18	Address Inputs
WE\	Write Enable
CE\	Chip Enable
OE\	Output Enable
I/O <sub>0</sub> - I/O <sub>7</sub>	Data Inputs/Outputs
V <sub>CC</sub>	Power
V <sub>SS</sub>	Ground
NC	No Connection



Austin Semiconductor, Inc.

# SRAM AS5C512K8

## ABSOLUTE MAXIMUM RATINGS\*

Voltage on Vcc Supply Relative to Vss

Vcc .....	-5V to +7.0V
Storage Temperature (Plastic).....	-65°C to +150°C
Storage Temperature (Ceramic).....	-55°C to +125°C
Short Circuit Output Current (per I/O).....	20mA
Voltage on any Pin Relative to Vss.....	-5V to Vcc+1V
Maximum Junction Temperature**.....	+150°C
Power Dissipation .....	1W

\*Stresses greater than those listed under "Absolute Maximum Ratings" may cause permanent damage to the device. This is a stress rating only and functional operation of the device at these or any other conditions above those indicated in the operation section of this specification is not implied. Exposure to absolute maximum rating conditions for extended periods may affect reliability.

\*\* Junction temperature depends upon package type, cycle time, loading, ambient temperature and airflow, and humidity.

## ELECTRICAL CHARACTERISTICS AND RECOMMENDED DC OPERATING CONDITIONS

(-55°C ≤ T<sub>A</sub> ≤ +125°C & -40°C ≤ T<sub>A</sub> ≤ +85°C ; Vcc = 5V ±10%)

DESCRIPTION	CONDITIONS	SYM	MAX						UNITS	NOTES
			-15	-17	-20	-25	-35	-45		
Power Supply Current: Operating	WE\=CE\<V <sub>IL</sub> ; Vcc = MAX f = MAX = 1/t <sub>RC</sub> Outputs Open	I <sub>CCSP</sub>	225	225	225	225	225	225	mA	3
	"L" Version Only	I <sub>CCLP</sub>	180	180	180	180	180	180	mA	
Power Supply Current: Standby	CE\ ≥ V <sub>IH</sub> , All other inputs ≤ V <sub>IL</sub> , Vcc = MAX, f = 0, Outputs Open	I <sub>SBTSP</sub>	60	60	60	60	60	60	mA	
	"L" Version Only	I <sub>SBTLP</sub>	30	30	30	30	30	30	mA	
	CE\ ≥ Vcc -0.2V; Vcc = MAX V <sub>IN</sub> ≤ Vss +0.2V or V <sub>IN</sub> ≥ Vcc -0.2V; f = 0	I <sub>SBCSP</sub>	25	25	25	25	25	25	mA	
	"L" Version Only	I <sub>SBCLP</sub>	10	10	10	10	10	10	mA	

DESCRIPTION	CONDITIONS	SYM	MIN	MAX	UNITS	NOTES
Input High (Logic 1) Voltage		V <sub>IH</sub>	2.2	Vcc +0.5	V	1
Input Low (Logic 0) Voltage		V <sub>IL</sub>	-0.5	0.8	V	1, 2
Input Leakage Current	0V ≤ V <sub>IN</sub> ≤ Vcc	I <sub>LI</sub>	-10	10	μA	
Output Leakage Current	Output(s) Disabled 0V ≤ V <sub>OUT</sub> ≤ Vcc	I <sub>LO</sub>	-10	10	μA	
Output High Voltage	I <sub>OH</sub> = -4.0 mA	V <sub>OH</sub>	2.4	---	V	1
Output Low Voltage	I <sub>OL</sub> = 8 mA	V <sub>OL</sub>	---	0.4	V	1
Supply Voltage		V <sub>CC</sub>	4.5	5.5	V	1

## CAPACITANCE

PARAMETER	CONDITIONS	SYMBOL	MAX	UNITS	NOTES
Input Capacitance	T <sub>A</sub> = 25°C, f = 1MHz V <sub>IN</sub> = 0	C <sub>I</sub>	12	pF	4
Output Capacitance		C <sub>O</sub>	14	pF	4



Austin Semiconductor, Inc.

# SRAM AS5C512K8

## ELECTRICAL CHARACTERISTICS AND RECOMMENDED AC OPERATING CONDITIONS

( $-55^{\circ}\text{C} \leq T_A \leq +125^{\circ}\text{C}$  or  $-40^{\circ}\text{C}$  to  $+85^{\circ}\text{C}$ ;  $V_{CC} = 5\text{V} \pm 10\%$ )

DESCRIPTION	SYM	-15		-17		-20		-25		-35		-45		UNITS	NOTES
		MIN	MAX	MIN	MAX	MIN	MAX	MIN	MAX	MIN	MAX	MIN	MAX		
<b>READ CYCLE</b>															
Read Cycle Time	$t_{RC}$	15		17		20		25		35		45		ns	
Address Access Time	$t_{AA}$		15		17		20		25		35		45	ns	
Chip Enable Access Time	$t_{ACE}$		15		17		20		25		35		45	ns	
Output Hold From Address Change	$t_{OH}$	2		2		2		2		2		2		ns	
Chip Enable to Output in Low-Z	$t_{LZCE}$	2		2		2		2		2		2		ns	4, 6, 7
Chip Disable to Output in High-Z	$t_{HZCE}$	0	7	0	8	0	8	0	10	0	15	0	20	ns	4, 6, 7
Output Enable Access Time	$t_{AOE}$		8		8		10		12		15		25	ns	
Output Enable to Output in Low-Z	$t_{LZOE}$	0		0		0		0		0		0		ns	4, 6, 7
Output Disable to Output in High-Z	$t_{HZOE}$	0	7	0	8	0	8	0	10	0	15	0	20	ns	4, 6, 7
<b>WRITE CYCLE</b>															
WRITE Cycle Time	$t_{WC}$	15		17		20		25		35		45		ns	
Chip Enable to End of Write	$t_{CW}$	15		16		17		20		30		35		ns	
Address Valid to End of Write	$t_{AW}$	15		16		17		20		30		35		ns	
Address Setup Time	$t_{AS}$	0		0		0		0		0		0		ns	
Address Hold From End of Write	$t_{AH}$	0		1		1		1		1		1		ns	
WRITE Pulse Width	$t_{WP}$	15		16		17		20		30		35		ns	
Data Setup Time	$t_{DS}$	7		9		10		12		20		25		ns	
Data Hold Time	$t_{DH}$	0		0		0		0		0		0		ns	
Write Disable to Output in Low-Z	$t_{LZWE}$	0		0		0		0		0		0		ns	4, 6, 7
Write Enable to Output in High-Z	$t_{HZWE}$	0	7	0	8	0	8	0	10	0	25	0	30	ns	4, 6, 7



**AC TEST CONDITIONS**

Input pulse levels .....	V <sub>SS</sub> to 3.0V
Input rise and fall times .....	3ns
Input timing reference levels .....	1.5V
Output reference levels .....	1.5V
Output load .....	See Figures 1 and 2

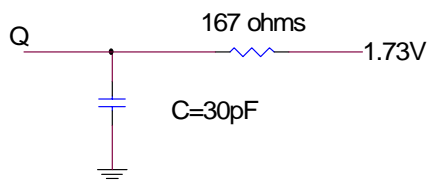

Fig. 1 Output Load Equivalent

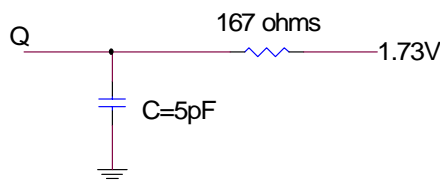

Fig. 2 Output Load Equivalent

**NOTES**

- All voltages referenced to V<sub>SS</sub> (GND).
- 2V for pulse width < 20ns
- I<sub>CC</sub> is dependent on output loading and cycle rates.
- This parameter is guaranteed but not tested.
- Test conditions as specified with the output loading as shown in Fig. 1 unless otherwise noted.
- ‘LZCE, ‘LZWE, ‘LZOE, ‘HZCE, ‘HZOE and ‘HZWE are specified with CL = 5pF as in Fig. 2. Transition is measured ±200mV from steady state voltage.
- At any given temperature and voltage condition, ‘HZCE is less than ‘LZCE, and ‘HZWE is less than ‘LZWE.
- WE\ is HIGH for READ cycle.
- Device is continuously selected. Chip enables and output enables are held in their active state.
- Address valid prior to, or coincident with, latest occurring chip enable.
- ‘RC = Read Cycle Time.
- Chip enable and write enable can initiate and terminate a WRITE cycle.
- Output enable (OE\ ) is inactive (HIGH).
- Output enable (OE\ ) is active (LOW).
- ASI does not warrant functionality nor reliability of any product in which the junction temperature exceeds 150°C. Care should be taken to limit power to acceptable levels.

**DATA RETENTION ELECTRICAL CHARACTERISTICS (L Version Only)**

DESCRIPTION	CONDITIONS	SYM	MIN	MAX	UNITS	NOTES
V <sub>CC</sub> for Retention Data	CE\ > V <sub>CC</sub> -0.2V V <sub>IN</sub> > V <sub>CC</sub> -0.2 or 0.2V	V <sub>DR</sub>	2		V	
Data Retention Current	V <sub>CC</sub> = 2.0V	I <sub>CCDR</sub>		4.5	mA	
Chip Deselect to Data		t <sub>CDR</sub>	0		ns	4
Operation Recovery Time		t <sub>R</sub>	10		ms	4, 11



Austin Semiconductor, Inc.

# SRAM AS5C512K8

## LOW $V_{CC}$ DATA RETENTION WAVEFORM

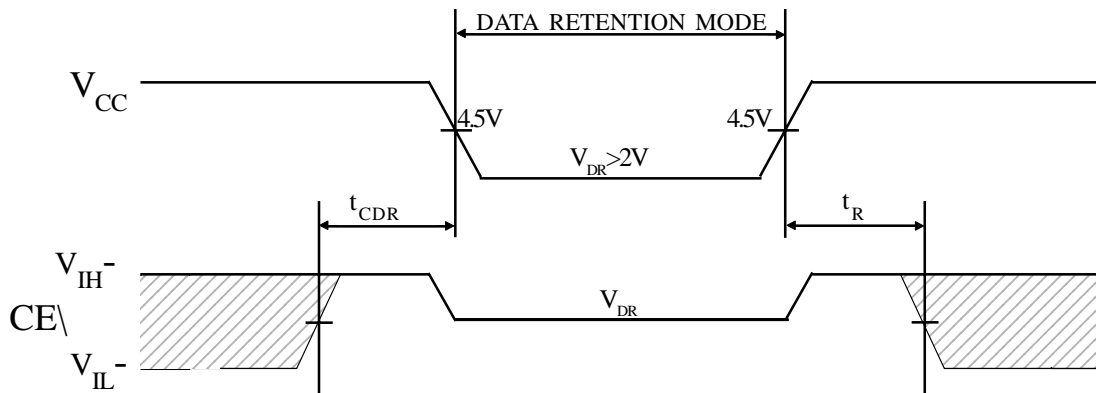

### READ CYCLE NO. 1<sup>8,9</sup>

(Address Controlled,  $CE\ =\ OE\ =\ V_{IL}$ ,  $WE\ =\ V_{IH}$ )

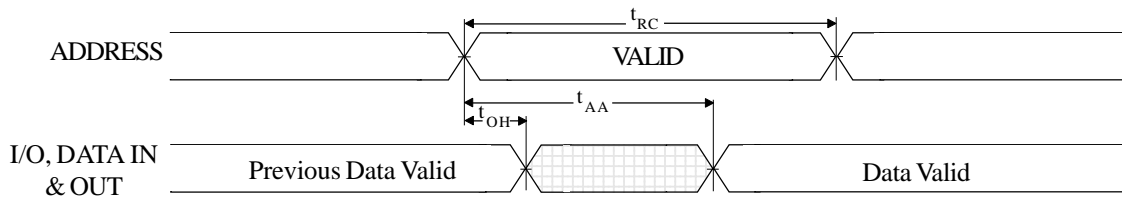

### READ CYCLE NO. 2<sup>2</sup>

( $WE\ =\ V_{IH}$ )

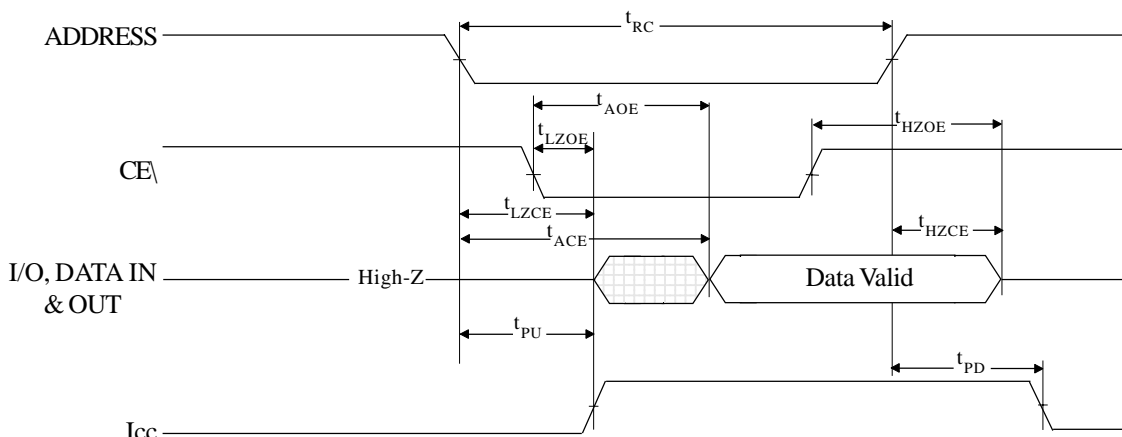

Don't Care

Undefined



**WRITE CYCLE NO. 1<sup>12</sup>**  
(CE Controlled)

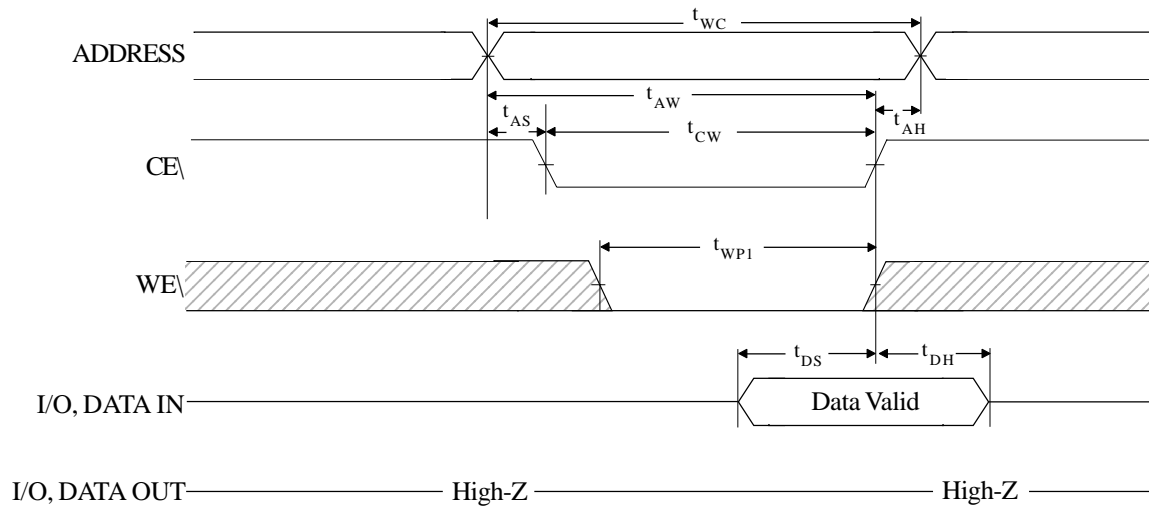

**WRITE CYCLE NO. 2<sup>12, 13</sup>**  
(Write Enabled Controlled)

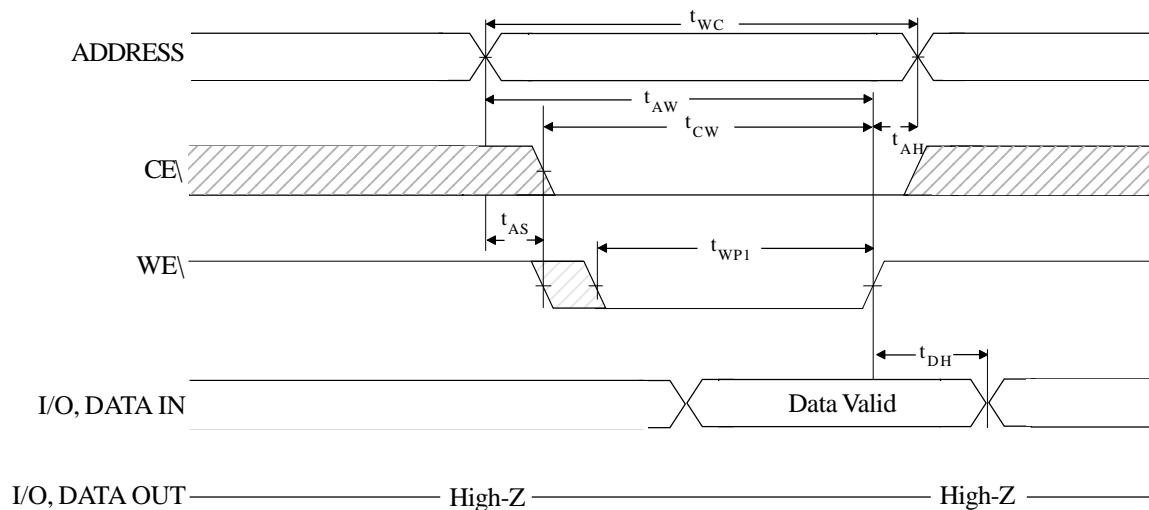



Austin Semiconductor, Inc.

**SRAM**  
**AS5C512K8**

**WRITE CYCLE NO. 3<sup>7,12,14</sup>**  
**(WE Controlled)**

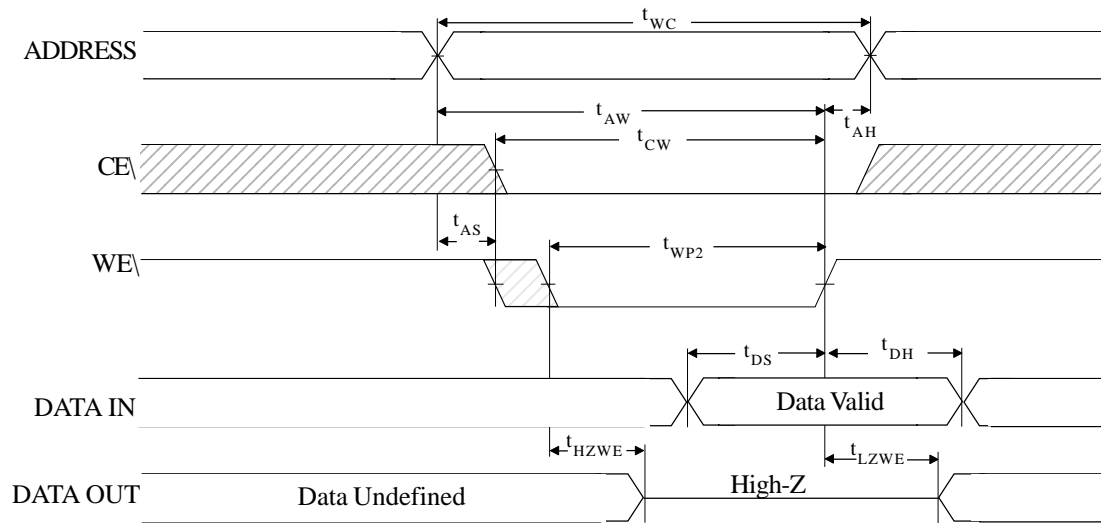



Austin Semiconductor, Inc.

**SRAM**  
**AS5C512K8**

**MECHANICAL DEFINITIONS\***

**ASI Case #210 (Package Designator EC)  
SMD 5962-95600, Case Outline N**

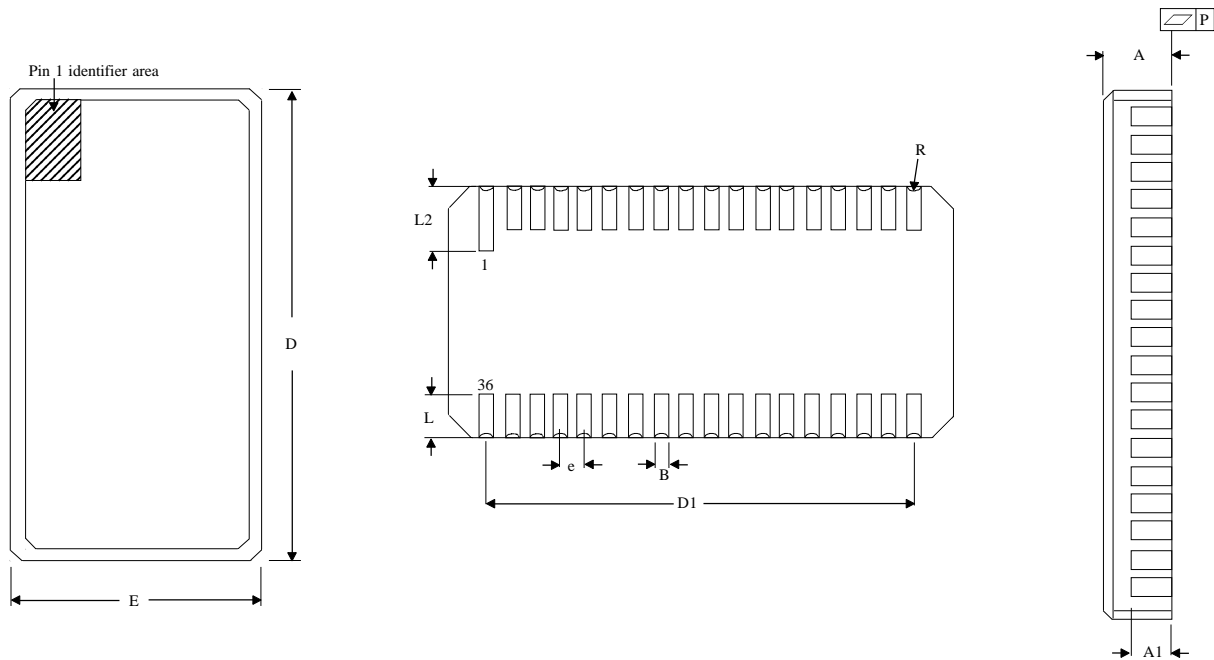

SYMBOL	SMD SPECIFICATIONS	
	MIN	MAX
A	0.080	0.100
A1	0.054	0.066
B	0.022	0.028
D	0.910	0.930
D1	0.840	0.860
E	0.445	0.460
e	0.050 BSC	
L	0.100 TYP	
L2	0.115	0.135
P	---	0.006
R	0.009 TYP	

\*All measurements are in inches.



Austin Semiconductor, Inc.

**SRAM**  
**AS5C512K8**

**MECHANICAL DEFINITIONS\***

ASI Case #307 (Package Designator F)  
SMD 5962-95600, Case Outline T

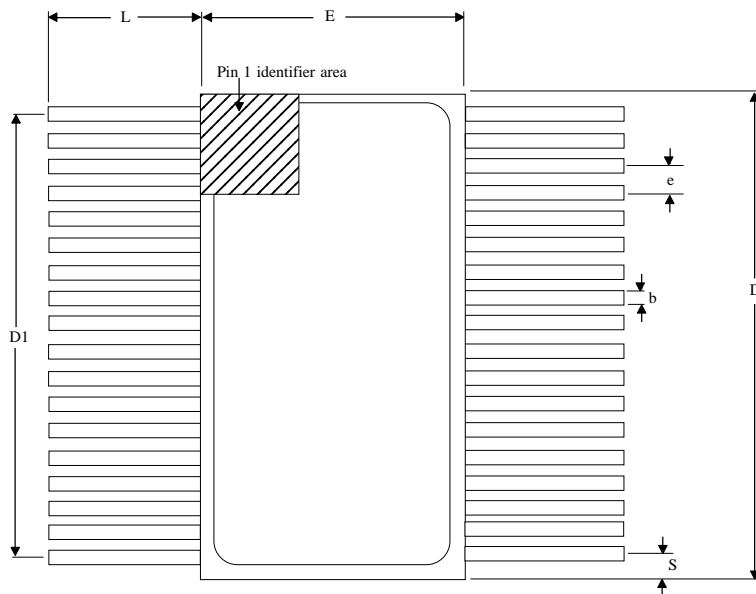

**Top View**

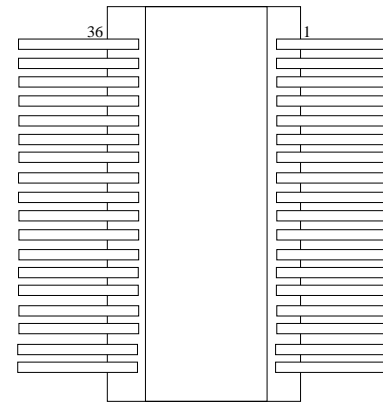

**Bottom View**

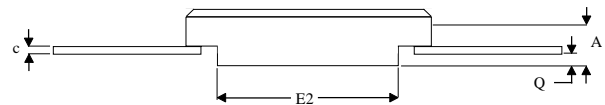

SYMBOL	SMD SPECIFICATIONS	
	MIN	MAX
A	0.096	0.125
b	0.015	0.022
c	0.003	0.009
D	0.910	0.930
D1	0.840	0.860
E	0.505	0.515
E2	0.385	0.397
e	0.050 BSC	
L	0.250	0.370
Q	0.020	0.045

\*All measurements are in inches.



Austin Semiconductor, Inc.

**SRAM**  
**AS5C512K8**

## MECHANICAL DEFINITIONS\*

ASI Case #503 (Package Designator ECJ)  
SMD 5962-95600, Case Outline M

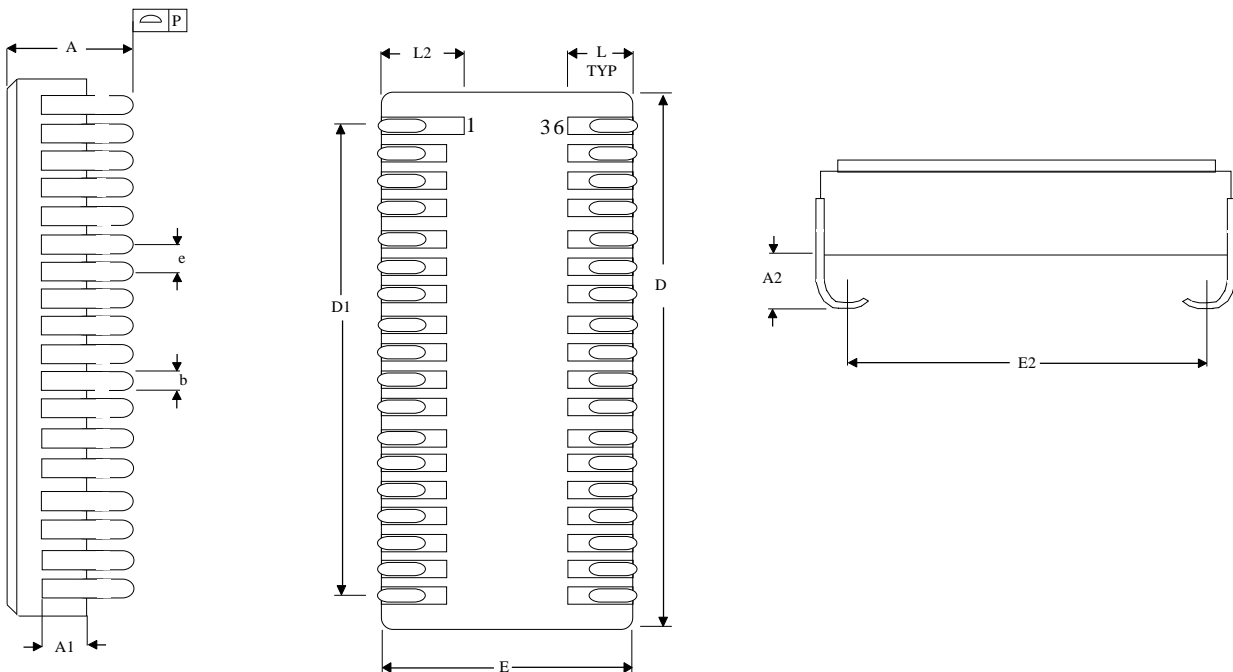

SYMBOL	SMD SPECIFICATIONS	
	MIN	MAX
A	0.140	0.160
A1	0.054	0.075
A2	0.025	0.063
b	0.019	0.028
D	0.910	0.939
D1	0.840	0.860
E	0.434	0.460
E2	0.374	0.410
e	0.050 BSC	
L	0.050	0.070
L2	0.115	0.135
P	---	0.004

\*All measurements are in inches.



Austin Semiconductor, Inc.

**SRAM**  
**AS5C512K8**

## MECHANICAL DEFINITIONS\*

ASI Case #903 (Package Designator DJ)

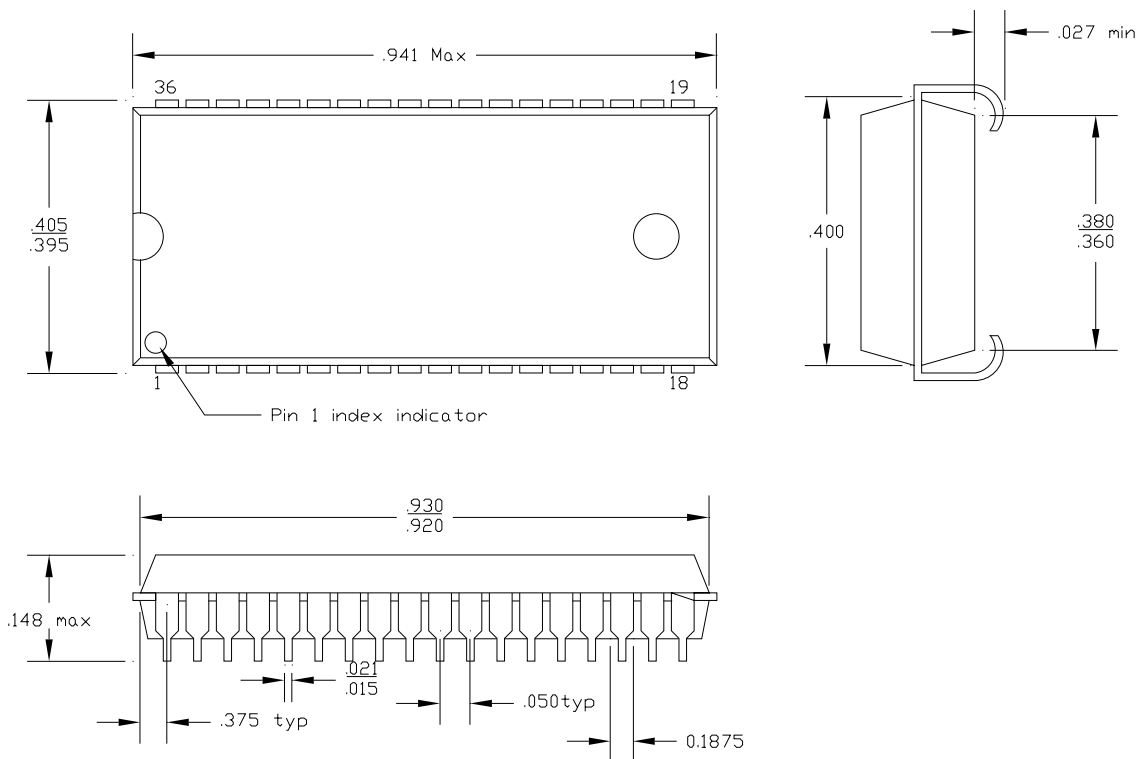

\*All measurements are in inches.

AS5C512K8  
Rev. 4.5-7/01

Austin Semiconductor, Inc. reserves the right to change products or specifications without notice.



Austin Semiconductor, Inc.

# SRAM AS5C512K8

## ORDERING INFORMATION

EXAMPLE: AS5C512K8F-25E/XT

Device Number	Package Type	Speed ns	Options**	Process
AS5C512K8	F	-15	L	/*
AS5C512K8	F	-15	E	/*
AS5C512K8	F	-17	L	/*
AS5C512K8	F	-17	E	/*
AS5C512K8	F	-20	L	/*
AS5C512K8	F	-20	E	/*
AS5C512K8	F	-25	L	/*
AS5C512K8	F	-25	E	/*
AS5C512K8	F	-30	L	/*
AS5C512K8	F	-30	E	/*
AS5C512K8	F	-45	L	/*
AS5C512K8	F	-45	E	/*

EXAMPLE: AS5C512K8ECJ-15/IT

Device Number	Package Type	Speed ns	Options**	Process
AS5C512K8	ECJ	-15	L	/*
AS5C512K8	ECJ	-15	E	/*
AS5C512K8	ECJ	-17	L	/*
AS5C512K8	ECJ	-17	E	/*
AS5C512K8	ECJ	-20	L	/*
AS5C512K8	ECJ	-20	E	/*
AS5C512K8	ECJ	-25	L	/*
AS5C512K8	ECJ	-25	E	/*
AS5C512K8	ECJ	-30	L	/*
AS5C512K8	ECJ	-30	E	/*
AS5C512K8	ECJ	-45	L	/*
AS5C512K8	ECJ	-45	E	/*

EXAMPLE: AS5C512K8EC-35LE/XT

Device Number	Package Type	Speed ns	Options**	Process
AS5C512K8	EC	-15	L	/*
AS5C512K8	EC	-15	E	/*
AS5C512K8	EC	-17	L	/*
AS5C512K8	EC	-17	E	/*
AS5C512K8	EC	-20	L	/*
AS5C512K8	EC	-20	E	/*
AS5C512K8	EC	-25	L	/*
AS5C512K8	EC	-25	E	/*
AS5C512K8	EC	-30	L	/*
AS5C512K8	EC	-30	E	/*
AS5C512K8	EC	-45	L	/*
AS5C512K8	EC	-45	E	/*

EXAMPLE: AS5C512K8DJ-20L/XT

Device Number	Package Type	Speed ns	Options**	Process
AS5C512K8	DJ	-15	L	/*
AS5C512K8	DJ	-15	E	/*
AS5C512K8	DJ	-17	L	/*
AS5C512K8	DJ	-17	E	/*
AS5C512K8	DJ	-20	L	/*
AS5C512K8	DJ	-20	E	/*
AS5C512K8	DJ	-25	L	/*
AS5C512K8	DJ	-25	E	/*
AS5C512K8	DJ	-30	L	/*
AS5C512K8	DJ	-30	E	/*
AS5C512K8	DJ	-45	L	/*
AS5C512K8	DJ	-45	E	/*

### \*AVAILABLE PROCESSES

IT = Industrial Temperature Range

XT = Extended Temperature Range

883C = Full Military Processing

-40°C to +85°C

-55°C to +125°C

-55°C to +125°C

### \*\*OPTIONS DEFINITIONS

L = 2V Data Retention / Low Power (Consult Factory)

E = Radiation Tolerant (EPI)



Austin Semiconductor, Inc.

**SRAM**  
**AS5C512K8**

**ASI TO DSCC PART NUMBER  
CROSS REFERENCE  
FOR SMD 5962-95600\***

**ASI Package Designator EC**

<b>ASI Part #</b>	<b>SMD Part #</b>
AS5C512K8EC-45/883C	5962-9560009MNA
AS5C512K8EC-45L/883C	5962-9560005MNA
AS5C512K8EC-35/883C	5962-9560010MNA
AS5C512K8EC-35L/883C	5962-9560006MNA
AS5C512K8EC-25/883C	5962-9560011MNA
AS5C512K8EC-25L/883C	5962-9560007MNA
AS5C512K8EC-20/883C	5962-9560012MNA
AS5C512K8EC-20L/883C	5962-9560008MNA
AS5C512K8EC-15/883C	5962-9560014MNA
AS5C512K8EC-15L/883C	5962-9560013MNA

**ASI Package Designator ECJ**

<b>ASI Part #</b>	<b>SMD Part #</b>
AS5C512K8ECJ-45/883C	5962-9560009MMA
AS5C512K8ECJ-45L/883C	5962-9560005MMA
AS5C512K8ECJ-35/883C	5962-9560010MMA
AS5C512K8ECJ-35L/883C	5962-9560006MMA
AS5C512K8ECJ-25/883C	5962-9560011MMA
AS5C512K8ECJ-25L/883C	5962-9560007MMA
AS5C512K8ECJ-20/883C	5962-9560012MMA
AS5C512K8ECJ-20L/883C	5962-9560008MMA
AS5C512K8ECJ-15/883C	5962-9560014MMA
AS5C512K8ECJ-15L/883C	5962-9560013MMA

**ASI Package Designator F**

<b>ASI Part #</b>	<b>SMD Part #</b>
AS5C512K8F-45/883C	5962-9560009MTA
AS5C512K8F-45L/883C	5962-9560005MTA
AS5C512K8F-35/883C	5962-9560010MTA
AS5C512K8F-35L/883C	5962-9560006MTA
AS5C512K8F-25/883C	5962-9560011MTA
AS5C512K8F-25L/883C	5962-9560007MTA
AS5C512K8F-20/883C	5962-9560012MTA
AS5C512K8F-20L/883C	5962-9560008MTA
AS5C512K8F-15/883C	5962-9560014MTA
AS5C512K8F-15L/883C	5962-9560013MTA

\* ASI part number is for reference only. Orders received referencing the SMD part number will be processed per the SMD.



Austin Semiconductor, Inc.

**SRAM**  
**AS5C512K8**

**ASI TO DSCC PART NUMBER  
CROSS REFERENCE  
FOR SMD 5962-95613\***

**ASI Package Designator EC**

**ASI Package Designator ECJ**

<b>ASI Part #</b>	<b>SMD Part #</b>
AS5C512K8EC-55/H	5962-9561305HNA
AS5C512K8EC-55L/H	5962-9561319HNA
AS5C512K8EC-45/H	5962-9561306HNA
AS5C512K8EC-45L/H	5962-9561320HNA
AS5C512K8EC-45/H	5962-9561311HNA
AS5C512K8EC-45L/H	5962-9561325HNA
AS5C512K8EC-35/H	5962-9561307HNA
AS5C512K8EC-35L/H	5962-9561321HNA
AS5C512K8EC-35/H	5962-9561312HNA
AS5C512K8EC-35L/H	5962-9561326HNA
AS5C512K8EC-25/H	5962-9561308HNA
AS5C512K8EC-25L/H	5962-9561322HNA
AS5C512K8EC-25/H	5962-9561313HNA
AS5C512K8EC-25L/H	5962-9561327HNA
AS5C512K8EC-20/H	5962-9561309HNA
AS5C512K8EC-20L/H	5962-9561323HNA
AS5C512K8EC-17/H	5962-9561310HNA
AS5C512K8EC-17L/H	5962-9561324HNA

<b>ASI Part #</b>	<b>SMD Part #</b>
AS5C512K8ECJ-55/H	5962-9561305HZA
AS5C512K8ECJ-55L/H	5962-9561319HZA
AS5C512K8ECJ-45/H	5962-9561306HZA
AS5C512K8ECJ-45L/H	5962-9561320HZA
AS5C512K8ECJ-45/H	5962-9561311HZA
AS5C512K8ECJ-45L/H	5962-9561325HZA
AS5C512K8ECJ-35/H	5962-9561307HZA
AS5C512K8ECJ-35L/H	5962-9561321HZA
AS5C512K8ECJ-35/H	5962-9561312HZA
AS5C512K8ECJ-35L/H	5962-9561326HZA
AS5C512K8ECJ-25/H	5962-9561308HZA
AS5C512K8ECJ-25L/H	5962-9561322HZA
AS5C512K8ECJ-25/H	5962-9561313HZA
AS5C512K8ECJ-25L/H	5962-9561327HZA
AS5C512K8ECJ-20/H	5962-9561309HZA
AS5C512K8ECJ-20L/H	5962-9561323HZA
AS5C512K8ECJ-17/H	5962-9561310HZA
AS5C512K8ECJ-17L/H	5962-9561324HZA

AS5C512K8EC-55/H	5962-9561305HNC
AS5C512K8EC-55L/H	5962-9561319HNC
AS5C512K8EC-45/H	5962-9561306HNC
AS5C512K8EC-45L/H	5962-9561320HNC
AS5C512K8EC-45/H	5962-9561311HNC
AS5C512K8EC-45L/H	5962-9561325HNC
AS5C512K8EC-35/H	5962-9561307HNC
AS5C512K8EC-35L/H	5962-9561321HNC
AS5C512K8EC-35/H	5962-9561312HNC
AS5C512K8EC-35L/H	5962-9561326HNC
AS5C512K8EC-25/H	5962-9561308HNC
AS5C512K8EC-25L/H	5962-9561322HNC
AS5C512K8EC-25/H	5962-9561313HNC
AS5C512K8EC-25L/H	5962-9561327HNC
AS5C512K8EC-20/H	5962-9561309HNC
AS5C512K8EC-20L/H	5962-9561323HNC
AS5C512K8EC-17/H	5962-9561310HNC
AS5C512K8EC-17L/H	5962-9561324HNC

AS5C512K8ECJ-55/H	5962-9561305HNC
AS5C512K8ECJ-55L/H	5962-9561319HNC
AS5C512K8ECJ-45/H	5962-9561306HNC
AS5C512K8ECJ-45L/H	5962-9561320HNC
AS5C512K8ECJ-45/H	5962-9561311HNC
AS5C512K8ECJ-45L/H	5962-9561325HNC
AS5C512K8ECJ-35/H	5962-9561307HNC
AS5C512K8ECJ-35L/H	5962-9561321HNC
AS5C512K8ECJ-35/H	5962-9561312HNC
AS5C512K8ECJ-35L/H	5962-9561326HNC
AS5C512K8ECJ-25/H	5962-9561308HNC
AS5C512K8ECJ-25L/H	5962-9561322HNC
AS5C512K8ECJ-25/H	5962-9561313HNC
AS5C512K8ECJ-25L/H	5962-9561327HNC
AS5C512K8ECJ-20/H	5962-9561309HNC
AS5C512K8ECJ-20L/H	5962-9561323HNC
AS5C512K8ECJ-17/H	5962-9561310HNC
AS5C512K8ECJ-17L/H	5962-9561324HNC

\* ASI part number is for reference only. Orders received referencing the SMD part number will be processed per the SMD.

Continued on next page.



Austin Semiconductor, Inc.

**SRAM**  
**AS5C512K8**

## ASI TO DSCC PART NUMBER CROSS REFERENCE FOR SMD 5962-95613\*

### ASI Package Designator F

<u>ASI Part #</u>	<u>SMD Part #</u>
AS5C512K8F-55/H	5962-9561305HUA
AS5C512K8F-55L/H	5962-9561319HUA
AS5C512K8F-45/H	5962-9561306HUA
AS5C512K8F-45L/H	5962-9561320HUA
AS5C512K8F-45/H	5962-9561311HUA
AS5C512K8F-45L/H	5962-9561325HUA
AS5C512K8F-35/H	5962-9561307HUA
AS5C512K8F-35L/H	5962-9561321HUA
AS5C512K8F-35/H	5962-9561312HUA
AS5C512K8F-35L/H	5962-9561326HUA
AS5C512K8F-25/H	5962-9561308HUA
AS5C512K8F-25L/H	5962-9561322HUA
AS5C512K8F-25/H	5962-9561313HUA
AS5C512K8F-25L/H	5962-9561327HUA
AS5C512K8F-20/H	5962-9561309HUA
AS5C512K8F-20L/H	5962-9561323HUA
AS5C512K8F-17/H	5962-9561310HUA
AS5C512K8F-17L/H	5962-9561324HUA
AS5C512K8F-55/H	5962-9561305HUC
AS5C512K8F-55L/H	5962-9561319HUC
AS5C512K8F-45/H	5962-9561306HUC
AS5C512K8F-45L/H	5962-9561320HUC
AS5C512K8F-45/H	5962-9561311HUC
AS5C512K8F-45L/H	5962-9561325HUC
AS5C512K8F-35/H	5962-9561307HUC
AS5C512K8F-35L/H	5962-9561321HUC
AS5C512K8F-35/H	5962-9561312HUC
AS5C512K8F-35L/H	5962-9561326HUC
AS5C512K8F-25/H	5962-9561308HUC
AS5C512K8F-25L/H	5962-9561322HUC
AS5C512K8F-25/H	5962-9561313HUC
AS5C512K8F-25L/H	5962-9561327HUC
AS5C512K8F-20/H	5962-9561309HUC
AS5C512K8F-20L/H	5962-9561323HUC
AS5C512K8F-17/H	5962-9561310HUC
AS5C512K8F-17L/H	5962-9561324HUC

\* ASI part number is for reference only. Orders received referencing the SMD part number will be processed per the SMD.