



Dual 2-Channel Simultaneous Sampling SAR 500 kSPS 16-Bit ADC

AD7654*

FEATURES

Dual 16-Bit 2-Channel Simultaneous Sampling ADC
16 Bits Resolution with No Missing Codes

Throughput:

500 kSPS (Normal Mode)

444 kSPS (Impulse Mode)

INL: ± 3.5 LSB Max ($\pm 0.0053\%$ of Full Scale)

SNR: 89 dB Typ @ 100 kHz

THD: -100 dB @ 100 kHz

Analog Input Voltage Range: 0 V to 5 V

No Pipeline Delay

Parallel and Serial 5 V/3 V Interface

SPI™ /QSPI™ /MICROWIRE™ /DSP Compatible

Single 5 V Supply Operation

Power Dissipation

120 mW Typical,

2.6 mW @ 10 kSPS

Package: 48-Lead Quad Flatpack (LQFP)

or 48-Lead Frame Chip Scale Package (LFCSP)

Low Cost

APPLICATIONS

AC Motor Control

3-Phase Power Control

4-Channel Data Acquisition

Uninterrupted Power Supplies

Communications

GENERAL DESCRIPTION

The AD7654 is a low cost, dual-channel, 16-bit, charge redistribution SAR, analog-to-digital converter that operates from a single 5 V power supply. It contains two low noise, wide bandwidth track-and-hold amplifiers that allow simultaneous sampling, a high speed 16-bit sampling ADC, an internal conversion clock, error correction circuits, and both serial and parallel system interface ports. Each track-and-hold has a multiplexer in front to provide a 4-channel input ADC.

The part features a very high sampling rate mode (Normal) and, for low power applications, a reduced power mode (Impulse) where the power is scaled with the throughput. It is available in 48-lead LQFP or 48-lead LFCSP packages with operation specified from -40°C to $+85^{\circ}\text{C}$.

PRODUCT HIGHLIGHTS

1. Simultaneous Sampling

The AD7654 features two sample-and-hold circuits that allow simultaneous sampling. It provides 4-channel inputs.

*Patent pending

SPI and QSPI are trademarks of Motorola, Inc.

Microwire is a trademark of National Semiconductor Corporation.

FUNCTIONAL BLOCK DIAGRAM

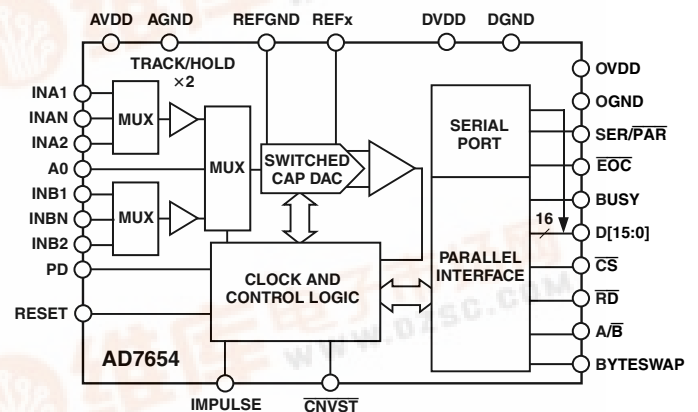

PulSAR Selection

Type/kSPS	100–250	500–570	800–1000
Pseudo Differential	AD7651 AD7660/ AD7661	AD7650/ AD7652 AD7664/ AD7666	AD7653 AD7667
True Bipolar	AD7663	AD7665	AD7671
True Differential	AD7675	AD7676	AD7677
18 Bit	AD7678	AD7679	AD7674
Multichannel/ Simultaneous		AD7654	

2. Fast Throughput

The AD7654 is a very high speed (500 kSPS in Normal Mode and 444 kSPS in Impulse Mode), charge redistribution, 16-bit SAR ADC that avoids pipeline delay.

3. Superior INL and No Missing Code

The AD7654 has a maximum integral nonlinearity of 3.5 LSB with no missing codes at the 16-bit level.

4. Single-Supply Operation

The AD7654 operates from a single 5 V supply and dissipates only 120 mW typical, even lower when a reduced throughput is used with the reduced power mode (Impulse) and power-down mode.

5. Serial or Parallel Interface

Versatile parallel or 2-wire serial interface arrangement is compatible with both 3 V or 5 V logic.

REV. 0

Information furnished by Analog Devices is believed to be accurate and reliable. However, no responsibility is assumed by Analog Devices for its use, nor for any infringements of patents or other rights of third parties that may result from its use. No license is granted by implication or otherwise under any patent or patent rights of Analog Devices.

One Technology Way, P.O. Box 9106, Norwood, MA 02062-9106, U.S.A.

Tel: 781/329-4700

Fax: 781/326-8703

www.analog.com

© Analog Devices, Inc. 2002

AD7654—SPECIFICATIONS (−40°C to +85°C, $V_{REF} = 2.5\text{ V}$, $AVDD = DVDD = 5\text{ V}$, $OVDD = 2.7\text{ V}$ to 5.25 V , unless otherwise noted.)

Parameter	Conditions	Min	Typ	Max	Unit
RESOLUTION		16			Bits
ANALOG INPUT					
Voltage Range	$V_{INx} - V_{INxN}$	0		$2 V_{REF}$	V
Common-Mode Input Voltage	V_{INxN}	−0.1		+0.5	V
Analog Input CMRR	$f_{IN} = 100\text{ kHz}$		55		dB
Input Current	500 kSPS Throughput		45		μA
Input Impedance		See Analog Input Section			
THROUGHPUT SPEED					
Complete Cycle	In Normal Mode			2	μs
Throughput Rate	In Normal Mode	0		500	kSPS
Complete Cycle	In Impulse Mode			2.25	μs
Throughput Rate	In Impulse Mode	0		444	kSPS
DC ACCURACY					
Integral Linearity Error		−3.5		+3.5	LSB ¹
No Missing Codes		16			Bits
Transition Noise			0.7		LSB
Full-Scale Error ²	T_{MIN} to T_{MAX}		± 0.25	± 0.5	% of FSR
Full-Scale Error Drift ²			± 2		ppm/°C
Unipolar Zero Error ²	T_{MIN} to T_{MAX}			± 0.25	% of FSR
Unipolar Zero Error Drift ²			± 0.8		ppm/°C
Power Supply Sensitivity	$AVDD = 5\text{ V} \pm 5\%$		0.8		LSB
AC ACCURACY					
Signal-to-Noise	$f_{IN} = 20\text{ kHz}$	88	90		dB ³
	$f_{IN} = 100\text{ kHz}$		89		dB
Spurious Free Dynamic Range	$f_{IN} = 100\text{ kHz}$		105		dB
Total Harmonic Distortion	$f_{IN} = 100\text{ kHz}$		−100		dB
Signal-to-(Noise+Distortion)	$f_{IN} = 20\text{ kHz}$	87.5	90		dB
	$f_{IN} = 100\text{ kHz}$		88.5		dB
	$f_{IN} = 100\text{ kHz}$, −60 dB Input		30		dB
Channel-to-Channel Isolation	$f_{IN} = 100\text{ kHz}$		−92		dB
−3 dB Input Bandwidth			10		MHz
SAMPLING DYNAMICS					
Aperture Delay ⁴			2		ns
Aperture Delay Matching ⁴			30		ps
Aperture Jitter ⁴			5		ps rms
Transient Response	Full-Scale Step			250	ns
REFERENCE					
External Reference Voltage Range		2.3	2.5	$AVDD/2$	V
External Reference Current Drain	500 kSPS Throughput		180		μA
DIGITAL INPUTS					
Logic Levels					
V_{IL}		−0.3		+0.8	V
V_{IH}		+2.0		$OVDD + 0.3$	V
I_{IL}		−1		+1	μA
I_{IH}		−1		+1	μA
DIGITAL OUTPUTS					
Data Format		Parallel or Serial 16-Bit Straight Binary Coding			
Pipeline Delay		Conversion Results Available Immediately after Completed Conversion			
V_{OL}	$I_{SINK} = 1.6\text{ mA}$			0.4	V
V_{OH}	$I_{SOURCE} = -500\text{ }\mu\text{A}$			$OVDD - 0.2$	V

Parameter	Conditions	Min	Typ	Max	Unit
POWER SUPPLIES					
Specified Performance					
AVDD		4.75	5	5.25	V
DVDD		4.75	5	5.25	V
OVDD		2.25		5.255	V
Operating Current ⁶	500 kSPS Throughput				
AVDD			15.5		mA
DVDD			8.5		mA
OVDD			100		μA
Power Dissipation	500 kSPS Throughput ⁶		120	135	mW
	10 kSPS Throughput ⁷		2.6		mW
	444 kSPS Throughput ⁷		114	125	mW
TEMPERATURE RANGE⁸					
Specified Performance	T _{MIN} to T _{MAX}	-40		+85	°C

NOTES

¹LSB means least significant bit. Within the 0 V to 5 V input range, one LSB is 76.294 μV.

²See Definition of Specifications section. These specifications do not include the error contribution from the external reference.

³All specifications in dB are referred to as full-scale input FS. Tested with an input signal at 0.5 dB below full scale unless otherwise specified.

⁴Sample tested during initial release.

⁵The maximum should be the minimum of 5.25 V and DVDD + 0.3 V.

⁶In Normal Mode.

⁷In Impulse Mode.

⁸Contact factory for extended temperature range.

Specifications subject to change without notice.

TIMING SPECIFICATIONS (-40°C to +85°C, AVDD = DVDD = 5 V, OVDD = 2.7 V to 5.25 V, unless otherwise noted.)

Parameter	Symbol	Min	Typ	Max	Unit
Refer to Figures 8 and 9					
Convert Pulsewidth	t ₁	5			ns
Time between Conversions (Normal Mode/Impulse Mode)	t ₂	2/2.25			μs
$\overline{\text{CNVST}}$ LOW to BUSY HIGH Delay	t ₃			32	ns
BUSY HIGH All Modes Except in Master Serial Read after Convert Mode (Normal Mode/Impulse Mode)	t ₄			1.75/2	μs
Aperture Delay	t ₅		2		ns
End of Conversions to BUSY LOW Delay	t ₆	10			ns
Conversion Time (Normal Mode/Impulse Mode)	t ₇			1.75/2	μs
Acquisition Time	t ₈	250			ns
RESET Pulsewidth	t ₉	10			ns
$\overline{\text{CNVST}}$ LOW to $\overline{\text{EOC}}$ HIGH Delay	t ₁₀			30	ns
$\overline{\text{EOC}}$ HIGH for Channel A Conversion (Normal Mode/Impulse Mode)	t ₁₁			1/1.25	μs
$\overline{\text{EOC}}$ LOW after Channel A Conversion	t ₁₂	45			ns
$\overline{\text{EOC}}$ HIGH for Channel B Conversion	t ₁₃			0.75	μs
Channel Selection Setup Time	t ₁₄	250			ns
Channel Selection Hold Time	t ₁₅			30	ns
Refer to Figures 10–14 (Parallel Interface Modes)					
$\overline{\text{CNVST}}$ LOW to DATA Valid Delay	t ₁₆			1.75/2	μs
DATA Valid to BUSY LOW Delay	t ₁₇	14			ns
Bus Access Request to DATA Valid	t ₁₈			40	ns
Bus Relinquish Time	t ₁₉	5		15	ns
A/B LOW to Data Valid Delay	t ₂₀			40	ns

AD7654

TIMING SPECIFICATIONS (continued)

Parameter	Symbol	Min	Typ	Max	Unit
Refer to Figures 15 and 16 (Master Serial Interface Modes)					
\overline{CS} LOW to SYNC Valid Delay	t_{21}			10	ns
\overline{CS} LOW to Internal SCLK Valid Delay	t_{22}			10	ns
\overline{CS} LOW to SDOUT Delay	t_{23}			10	ns
\overline{CNVST} LOW to SYNC Delay (Read during Convert) (Normal Mode/Impulse Mode)	t_{24}		250/500		ns
SYNC Asserted to SCLK First Edge Delay*	t_{25}	3			ns
Internal SCLK Period*	t_{26}	23		40	ns
Internal SCLK HIGH*	t_{27}	12			ns
Internal SCLK LOW*	t_{28}	7			ns
SDOUT Valid Setup Time*	t_{29}	4			ns
SDOUT Valid Hold Time*	t_{30}	2			ns
SCLK Last Edge to SYNC Delay*	t_{31}	1			ns
\overline{CS} HIGH to SYNC HI-Z	t_{32}			10	ns
\overline{CS} HIGH to Internal SCLK HI-Z	t_{33}			10	ns
\overline{CS} HIGH to SDOUT HI-Z	t_{34}			10	ns
BUSY HIGH in Master Serial Read after Convert (Normal Mode/Impulse Mode)	t_{35}			See Table I	
\overline{CNVST} LOW to SYNC Asserted Delay (Normal Mode/Impulse Mode)	t_{36}		0.75/1		μ s
SYNC Deasserted to BUSY LOW Delay	t_{37}		25		ns
Refer to Figures 17 and 18 (Slave Serial Interface Modes)					
External SCLK Setup Time	t_{38}	5			ns
External SCLK Active Edge to SDOUT Delay	t_{39}	3		18	ns
SDIN Setup Time	t_{40}	5			ns
SDIN Hold Time	t_{41}	5			ns
External SCLK Period	t_{42}	25			ns
External SCLK HIGH	t_{43}	10			ns
External SCLK LOW	t_{44}	10			ns

*In Serial Master Read during Convert Mode. See Table I for Serial Master Read after Convert Mode.

Specifications subject to change without notice.

Table I. Serial Clock Timings in Master Read after Convert

DIVSCLK[1] DIVSCLK[0]		0 0	0 1	1 0	1 1	Unit
SYNC to SCLK First Edge Delay Minimum	t_{25}	3	17	17	17	ns
Internal SCLK Period Minimum	t_{26}	25	50	100	200	ns
Internal SCLK Period Typical	t_{26}	40	70	140	280	ns
Internal SCLK HIGH Minimum	t_{27}	12	22	50	100	ns
Internal SCLK LOW Minimum	t_{28}	7	21	49	99	ns
SDOUT Valid Setup Time Minimum	t_{29}	4	18	18	18	ns
SDOUT Valid Hold Time Minimum	t_{30}	2	4	30	80	ns
SCLK Last Edge to SYNC Delay Minimum	t_{31}	1	3	30	80	ns
Busy High Width Maximum (Normal)	t_{35}	3.25	4.25	6.25	10.75	μ s
Busy High Width Maximum (Impulse)	t_{35}	3.5	4.5	6.5	11	μ s

ABSOLUTE MAXIMUM RATINGS¹

Analog Input	
INAx ² , INBx ² , REFx, INxN, REFGND	AGND – 0.3 V to AVDD + 0.3 V
Ground Voltage Differences	
AGND, DGND, OGND	±0.3 V
Supply Voltages	
AVDD, DVDD, OVDD	–0.3 V to +7 V
AVDD to DVDD, AVDD to OVDD	±7 V
DVDD to OVDD	–0.3 V to +7 V
Digital Inputs	–0.3 V to DVDD + 0.3 V
Internal Power Dissipation ³	700 mW
Internal Power Dissipation ⁴	2.5 W

Junction Temperature	150°C
Storage Temperature Range	–65°C to +150°C
Lead Temperature Range	
(Soldering 10 sec)	300°C

NOTES

¹Stresses above those listed under Absolute Maximum Ratings may cause permanent damage to the device. This is a stress rating only; functional operation of the device at these or any other conditions above those indicated in the operational section of this specification is not implied. Exposure to absolute maximum rating conditions for extended periods may affect device reliability.

²See Analog Input section.

³Specification is for device in free air: 48-Lead LQFP: $\theta_{JA} = 91^\circ\text{C/W}$, $\theta_{JC} = 30^\circ\text{C/W}$.

⁴Specification is for device in free air: 48-Lead LFCSP: $\theta_{JA} = 26^\circ\text{C/W}$.

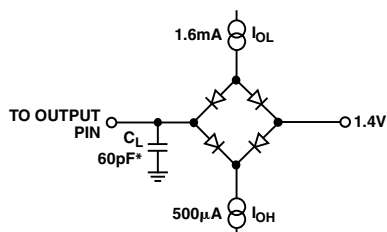

*IN SERIAL INTERFACE MODES, THE SYNC, SCLK, AND SDOUT TIMINGS ARE DEFINED WITH A MAXIMUM LOAD C_L OF 10pF; OTHERWISE, THE LOAD IS 60pF MAXIMUM.

Figure 1. Load Circuit for Digital Interface Timing, SDOUT, SYNC, SCLK Outputs, C_L = 10 pF

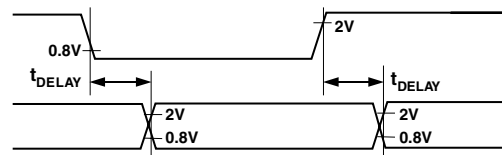

Figure 2. Voltage Reference Levels for Timing

ORDERING GUIDE

Model	Temperature Range	Package Description	Package Option
AD7654AST	–40°C to +85°C	Quad Flatpack (LQFP)	ST-48
AD7654ASTRL	–40°C to +85°C	Quad Flatpack (LQFP)	ST-48
AD7654ACP	–40°C to +85°C	Chip Scale Package (LFCSP)	CP-48
AD7654ACPRL	–40°C to +85°C	Chip Scale Package (LFCSP)	CP-48
EVAL-AD7654CB ¹		Evaluation Board	
EVAL-CONTROL BRD ²		Controller Board	

NOTES

¹This board can be used as a standalone evaluation board or in conjunction with the EVAL-CONTROL BRD2 for evaluation/demonstration purposes.

²This board allows a PC to control and communicate with all Analog Devices evaluation boards ending in the CB designators.

CAUTION

ESD (electrostatic discharge) sensitive device. Electrostatic charges as high as 4000 V readily accumulate on the human body and test equipment and can discharge without detection. Although the AD7654 features proprietary ESD protection circuitry, permanent damage may occur on devices subjected to high energy electrostatic discharges. Therefore, proper ESD precautions are recommended to avoid performance degradation or loss of functionality.



AD7654

PIN CONFIGURATION

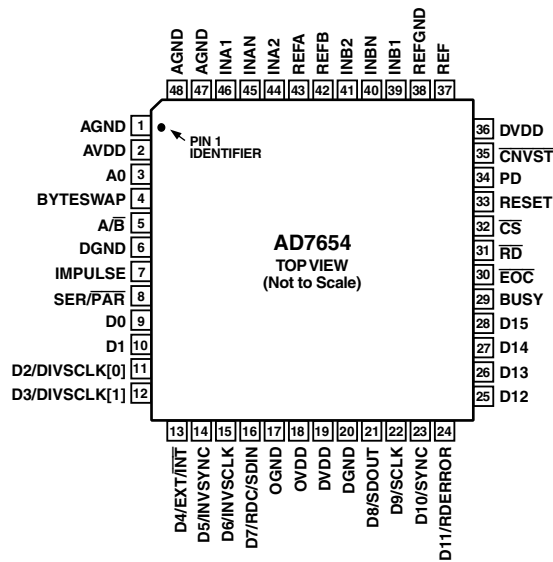

PIN FUNCTION DESCRIPTIONS

Pin No.	Mnemonic	Type	Description
1, 47, 48	AGND	P	Analog Power Ground Pin
2	AVDD	P	Input Analog Power Pin. Nominally 5 V.
3	A0	DI	Multiplexer Select. When LOW, the analog inputs INA1 and INB1 are sampled simultaneously, then converted. When HIGH, the analog inputs INA2 and INB2 are sampled simultaneously, then converted.
4	BYTESWAP	DI	Parallel Mode Selection (8 Bit, 16 Bit). When LOW, the LSB is output on D[7:0] and the MSB is output on D[15:8]. When HIGH, the LSB is output on D[15:8] and the MSB is output on D[7:0].
5	A/B	DI	Data Channel Selection. In parallel mode, when LOW, the data from channel B is read. When HIGH, the data from channel A is read. In serial mode, when HIGH, channel A is output first followed by channel B. When LOW, channel B is output first followed by channel B.
6, 20	DGND	P	Digital Power Ground
7	IMPULSE	DI	Mode Selection. When HIGH, this input selects a reduced power mode. In this mode, the power dissipation is approximately proportional to the sampling rate.
8	SER/ $\overline{\text{PAR}}$	DI	Serial/Parallel Selection Input. When LOW, the parallel port is selected; when HIGH, the serial interface mode is selected and some bits of the DATA bus are used as a serial port.
9, 10	D[0:1]	DO	Bit 0 and Bit 1 of the Parallel Port Data Output Bus. When SER/ $\overline{\text{PAR}}$ is HIGH, these outputs are in high impedance.
11, 12	D[2:3] or DIVSCLK[0:1]	DI/O	When SER/ $\overline{\text{PAR}}$ is LOW, these outputs are used as Bit 2 and Bit 3 of the Parallel Port Data Output Bus. When SER/ $\overline{\text{PAR}}$ is HIGH, EXT/ $\overline{\text{INT}}$ is LOW, and RDC/SDIN is LOW, which is the serial master read after convert mode, these inputs, part of the serial port, are used to slow down if desired the internal serial clock that clocks the data output. In the other serial modes, these inputs are not used.
13	D[4] or EXT/INT	DI/O	When SER/ $\overline{\text{PAR}}$ is LOW, this output is used as Bit 4 of the Parallel Port Data Output Bus. When SER/ $\overline{\text{PAR}}$ is HIGH, this input, part of the serial port, is used as a digital select input for choosing the internal or an external data clock, called respectively, Master and Slave Mode. With EXT/INT tied LOW, the internal clock is selected on SCLK output. With EXT/INT set to a logic HIGH, output data is synchronized to an external clock signal connected to the SCLK input.

Pin No.	Mnemonic	Type	Description
14	D[5] or INVSYNC	DI/O	<p>When $\overline{\text{SER/}\overline{\text{PAR}}}$ is LOW, this output is used as Bit 5 of the Parallel Port Data Output Bus.</p> <p>When $\overline{\text{SER/}\overline{\text{PAR}}}$ is HIGH, this input, part of the serial port, is used to select the active state of the SYNC signal. When LOW, SYNC is active HIGH. When HIGH, SYNC is active LOW.</p>
15	D[6] or INVCLK	DI/O	<p>When $\overline{\text{SER/}\overline{\text{PAR}}}$ is LOW, this output is used as Bit 6 of the Parallel Port Data Output Bus.</p> <p>When $\overline{\text{SER/}\overline{\text{PAR}}}$ is HIGH, this input, part of the serial port, is used to invert the SCLK signal. It is active in both Master and Slave modes.</p>
16	D[7] or RDC/SDIN	DI/O	<p>When $\overline{\text{SER/}\overline{\text{PAR}}}$ is LOW, this output is used as Bit 7 of the Parallel Port Data Output Bus.</p> <p>When $\overline{\text{SER/}\overline{\text{PAR}}}$ is HIGH, this input, part of the serial port, is used as either an external data input or a read mode selection input, depending on the state of $\overline{\text{EXT/}\overline{\text{INT}}}$.</p> <p>When $\overline{\text{EXT/}\overline{\text{INT}}}$ is HIGH, RDC/SDIN can be used as a data input to daisy-chain the conversion results from two or more ADCs onto a single SDOUT line. The digital data level on SDIN is output on SDOUT with a delay of 32 SCLK periods after the initiation of the read sequence.</p> <p>When $\overline{\text{EXT/}\overline{\text{INT}}}$ is LOW, RDC/SDIN is used to select the read mode. When RDC/SDIN is HIGH, the previous data is output on SDOUT during conversion. When RDC/SDIN is LOW, the data can be output on SDOUT only when the conversion is complete.</p>
17	OGND	P	Input/Output Interface Digital Power Ground
18	OVDD	P	Input/Output Interface Digital Power. Nominally at the same supply as the supply of the host interface (5 V or 3 V).
19, 36	DVDD	P	Digital Power. Nominally at 5 V.
21	D[8] or SDOUT	DO	<p>When $\overline{\text{SER/}\overline{\text{PAR}}}$ is LOW, this output is used as Bit 8 of the Parallel Port Data Output Bus.</p> <p>When $\overline{\text{SER/}\overline{\text{PAR}}}$ is HIGH, this output, part of the serial port, is used as a serial data output synchronized to SCLK. Conversion results are stored in a 32-bit on-chip register. The AD7654 provides the two conversion results, MSB first, from its internal shift register. The order of channel outputs is controlled by A/B. In serial mode, when $\overline{\text{EXT/}\overline{\text{INT}}}$ is LOW, SDOUT is valid on both edges of SCLK.</p> <p>In Serial Mode, when $\overline{\text{EXT/}\overline{\text{INT}}}$ is HIGH:</p> <p>If INVCLK is LOW, SDOUT is updated on the SCLK rising edge and valid on the next falling edge.</p> <p>If INVCLK is HIGH, SDOUT is updated on the SCLK falling edge and valid on the next rising edge.</p>
22	D[9] or SCLK	DI/O	<p>When $\overline{\text{SER/}\overline{\text{PAR}}}$ is LOW, this output is used as Bit 9 of the Parallel Port Data Output Bus.</p> <p>When $\overline{\text{SER/}\overline{\text{PAR}}}$ is HIGH, this pin, part of the serial port, is used as a serial data clock input or output, dependent upon the logic state of the $\overline{\text{EXT/}\overline{\text{INT}}}$ pin. The active edge where the data SDOUT is updated depends on the logic state of the INVCLK pin.</p>
23	D[10] or SYNC	DO	<p>When $\overline{\text{SER/}\overline{\text{PAR}}}$ is LOW, this output is used as Bit 10 of the Parallel Port Data Output Bus.</p> <p>When $\overline{\text{SER/}\overline{\text{PAR}}}$ is HIGH, this output, part of the serial port, is used as a digital output frame synchronization for use with the internal data clock ($\overline{\text{EXT/}\overline{\text{INT}}} = \text{Logic LOW}$).</p> <p>When a read sequence is initiated and INVSYNC is LOW, SYNC is driven HIGH and frames SDOUT. After the first channel is output, SYNC is pulsed LOW. When a read sequence is initiated and INVSYNC is HIGH, SYNC is driven LOW and remains LOW while SDOUT output is valid. After the first channel is output, SYNC is pulsed HIGH.</p>

AD7654

PIN FUNCTION DESCRIPTIONS (continued)

Pin No.	Mnemonic	Type	Description
24	D[11] or RDERROR	DO	When $\overline{\text{SER/PA}}\overline{\text{R}}$ is LOW, this output is used as Bit 11 of the Parallel Port Data Output Bus. When $\overline{\text{SER/PA}}\overline{\text{R}}$ is HIGH and $\overline{\text{EXT/INT}}$ is HIGH, this output, part of the serial port, is used as an incomplete read error flag. In Slave mode, when a data read is started and not complete when the following conversion is complete, the current data is lost and RDERROR is pulsed high.
25–28	D[12:15]	DO	Bit 12 to Bit 15 of the Parallel Port Data Output Bus. When $\overline{\text{SER/PA}}\overline{\text{R}}$ is HIGH, these outputs are in high impedance.
29	BUSY	DO	Busy Output. Transitions HIGH when a conversion is started and remains HIGH until the two conversions are complete and the data are latched into the on-chip shift register. The falling edge of BUSY can be used as a data ready clock signal.
30	$\overline{\text{EOC}}$	DO	End of Convert Output. Goes LOW at each channel conversion.
31	$\overline{\text{RD}}$	DI	Read Data. When $\overline{\text{CS}}$ and $\overline{\text{RD}}$ are both LOW, the interface parallel or serial output bus is enabled.
32	$\overline{\text{CS}}$	DI	Chip Select. When $\overline{\text{CS}}$ and $\overline{\text{RD}}$ are both LOW, the interface parallel or serial output bus is enabled. $\overline{\text{CS}}$ is also used to gate the external serial clock.
33	RESET	DI	Reset Input. When set to a logic HIGH, reset the AD7654. Current conversion if any is aborted. If not used, this pin could be tied to DGND.
34	PD	DI	Power-Down Input. When set to a logic HIGH, power consumption is reduced and conversions are inhibited after the current one is completed.
35	$\overline{\text{CNVST}}$	DI	Start Conversion. A falling edge on $\overline{\text{CNVST}}$ puts the internal sample-and-hold into the hold state and initiates a conversion. In Impulse Mode (IMPULSE HIGH), if $\overline{\text{CNVST}}$ is held low when the acquisition phase (t_{S}) is complete, the internal sample-and-hold is put into the hold state and a conversion is immediately started.
37	REF	AI	This input pin is used to provide a reference to the converter.
38	REFGND	AI	Reference Input Analog Ground
39, 41	INB1, INB2	AI	Analog Inputs
40, 45	INBN, INAN	AI	Analog Inputs Ground Senses. Allow to sense each channel ground independently.
42, 43	REFB, REFA	AI	These inputs are the references applied to channel A and channel B, respectively.
44, 46	INA2, INA1		

NOTES

AI = Analog Input
 DI = Digital Input
 DI/O = Bidirectional Digital
 DO = Digital Output
 P = Power

DEFINITION OF SPECIFICATIONS**Integral Nonlinearity Error (INL)**

Linearity error refers to the deviation of each individual code from a line drawn from negative full scale through positive full scale. The point used as negative full scale occurs 1/2 LSB before the first code transition. Positive full scale is defined as a level 1 1/2 LSB beyond the last code transition. The deviation is measured from the middle of each code to the true straight line.

Differential Nonlinearity Error (DNL)

In an ideal ADC, code transitions are 1 LSB apart. Differential nonlinearity is the maximum deviation from this ideal value. It is often specified in terms of resolution for which no missing codes are guaranteed.

Full-Scale Error

The last transition (from 111 . . . 10 to 111 . . . 11) should occur for an analog voltage 1 1/2 LSB below the nominal full scale (4.999886 V for the 0 V to 5 V range). The full-scale error is the deviation of the actual level of the last transition from the ideal level.

Unipolar Zero Error

In unipolar mode, the first transition should occur at a level 1/2 LSB above analog ground. The unipolar zero error is the deviation of the actual transition from that point.

Spurious-Free Dynamic Range (SFDR)

The difference, in decibels, between the rms amplitude of the input signal and the peak spurious signal.

Effective Number of Bits (ENOB)

ENOB is a measurement of the resolution with a sine wave input. It is related to $S/(N+D)$ by the following formula:

$$ENOB = \left(S/[N + D]_{dB} - 1.76 \right) / 6.02$$

and is expressed in bits.

Total Harmonic Distortion (THD)

THD is the ratio of the rms sum of the first five harmonic components to the rms value of a full-scale input signal and is expressed in decibels.

Signal-to-Noise Ratio (SNR)

SNR is the ratio of the rms value of the actual input signal to the rms sum of all other spectral components below the Nyquist frequency, excluding harmonics and dc. The value for SNR is expressed in decibels.

Signal-to-(Noise+Distortion) Ratio (S/[N+D])

$S/(N+D)$ is the ratio of the rms value of the actual input signal to the rms sum of all other spectral components below the Nyquist frequency, including harmonics but excluding dc. The value for $S/(N+D)$ is expressed in decibels.

Aperture Delay

Aperture delay is a measure of the acquisition performance and is measured from the falling edge of the \overline{CNVST} input to when the input signals are held for a conversion.

Transient Response

The time required for the AD7654 to achieve its rated accuracy after a full-scale step function is applied to its input.

AD7654—Typical Performance Characteristics

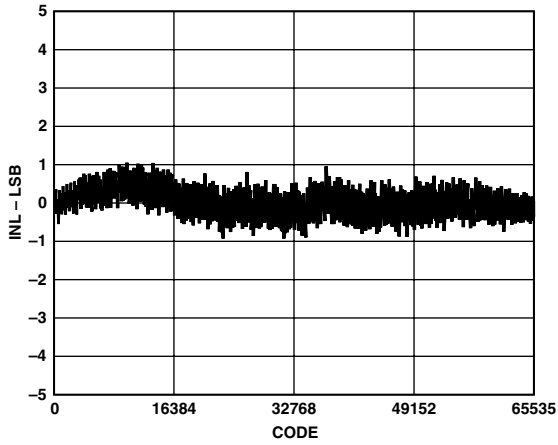

TPC 1. Integral Nonlinearity vs. Code

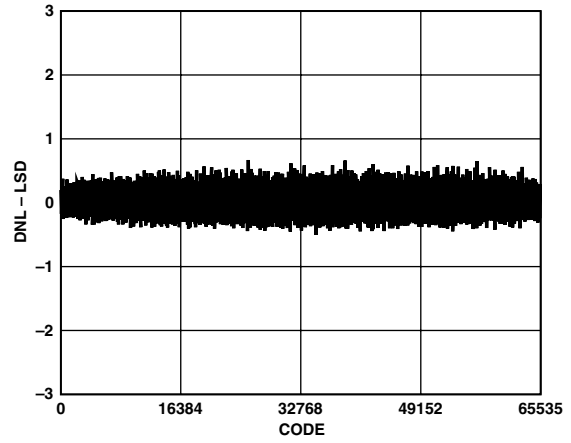

TPC 4. Differential Nonlinearity vs. Code

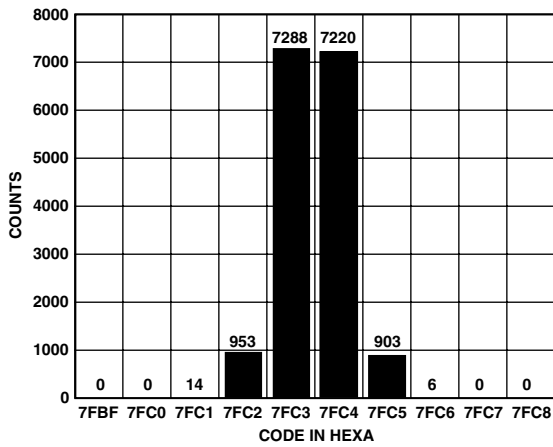

TPC 2. Histogram of 16,384 Conversions of a DC Input at the Code Transition

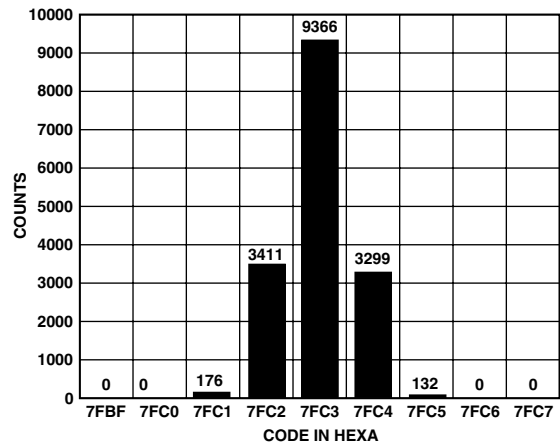

TPC 5. Histogram of 16,384 Conversions of a DC Input at the Code Center

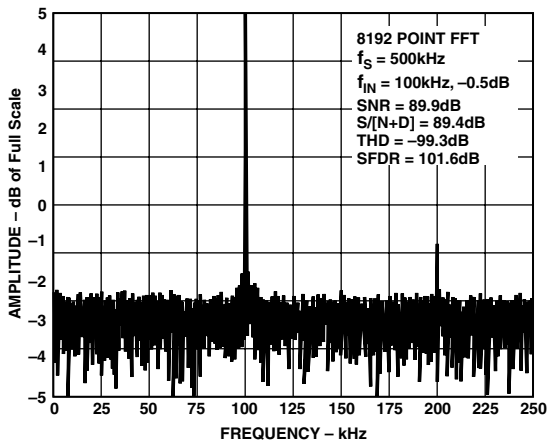

TPC 3. FFT Plot

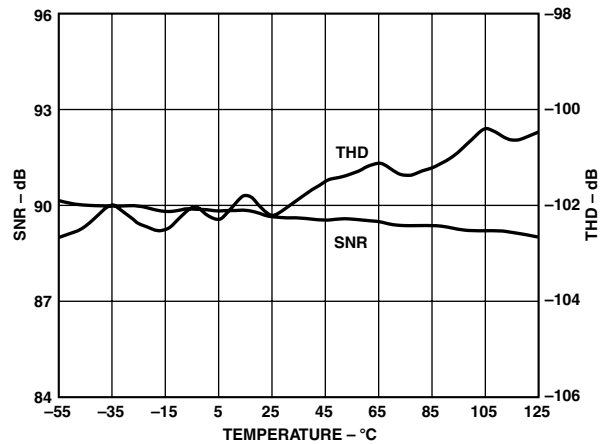

TPC 6. SNR, THD vs. Temperature

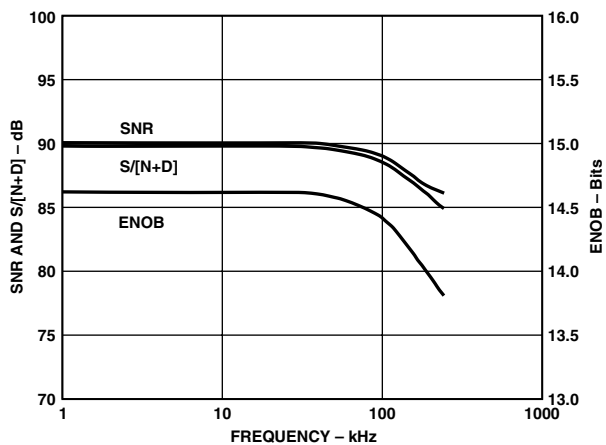

TPC 7. SNR, S/(N+D), and ENOB vs. Frequency

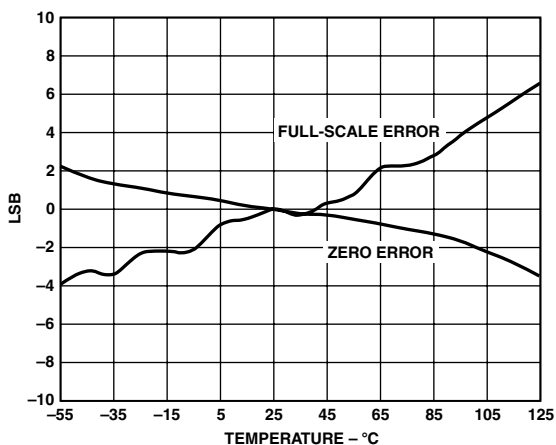

TPC 10. Full-Scale and Zero Error vs. Temperature

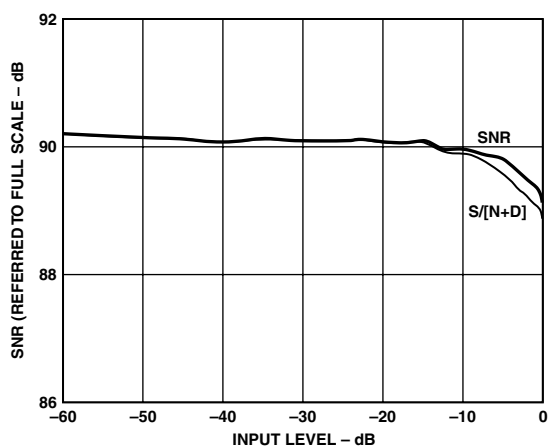

TPC 8. SNR and S/(N+D) vs. Input Level (Referred to Full Scale)

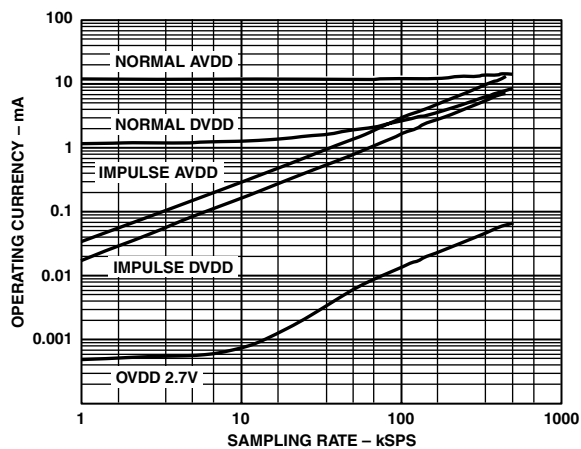

TPC 11. Operating Currents vs. Sample Rate

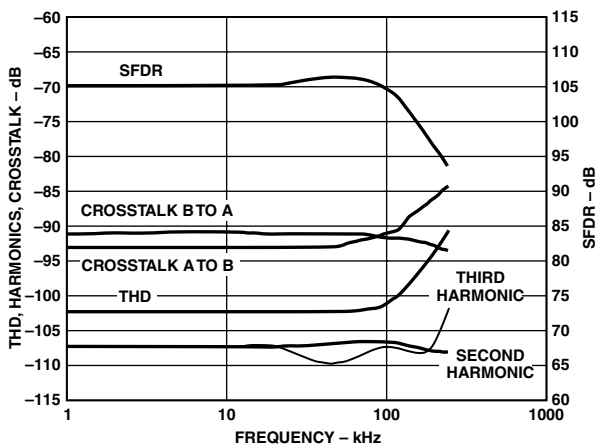

TPC 9. THD, Harmonics, Crosstalk, and SFDR vs. Frequency

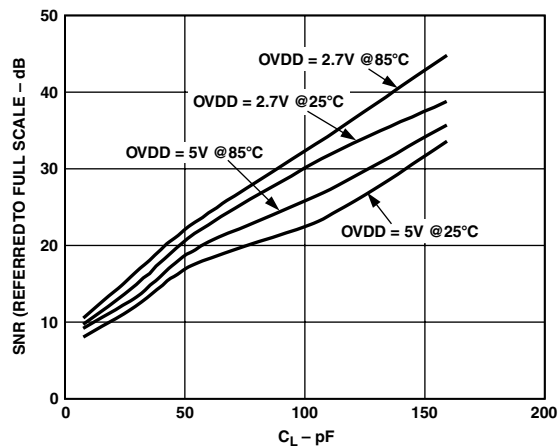

TPC 12. Typical Delay vs. Load Capacitance C_L

AD7654

CIRCUIT INFORMATION

The AD7654 is a very fast, low power, single-supply, precise simultaneous sampling 16-bit analog-to-digital converter (ADC).

The AD7654 provides the user with two on-chip track-and-hold, successive approximation ADCs that do not exhibit any pipeline or latency, making it ideal for multiple multiplexed channel applications. The AD7654 can be also used as a 4-channel ADC with two pairs simultaneously sampled.

The AD7654 can be operated from a single 5 V supply and be interfaced to either 5 V or 3 V digital logic. It is housed in 48-lead LQFP or tiny 48-lead LFCSP packages that combine space savings and allow flexible configurations as either a serial or parallel interface. The AD7654 is pin-to-pin-compatible with PulSAR ADCs.

Modes of Operation

The AD7654 features two modes of operation, Normal and Impulse. Each of these modes is more suitable for specific applications.

The Normal Mode is the fastest mode (500 kSPS). Except when it is powered down (PD HIGH), the power dissipation is almost independent of the sampling rate.

The Impulse Mode, the lowest power dissipation mode, allows power saving between conversions. The maximum throughput in this mode is 444 kSPS. When operating at 10 kSPS, for example, it typically consumes only 2.6 mW. This feature makes the AD7654 ideal for battery-powered applications.

Transfer Functions

The AD7654 data format is straight binary. The ideal transfer characteristic for the AD7654 is shown in Figure 3 and Table I.

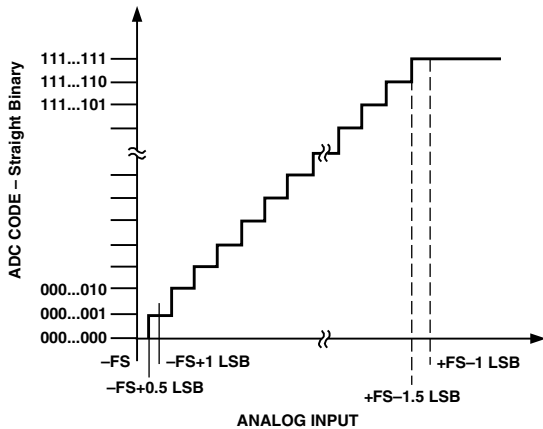

Figure 3. ADC Ideal Transfer Function

Table I. Output Codes and Ideal Input Voltages

Description	Analog Input $V_{REF} = 2.5 \text{ V}$	Digital Output Code (Hexa)
FSR - 1 LSB	4.999924 V	FFFF ¹
FSR - 2 LSB	4.999847 V	FFFE
Midscale + 1 LSB	2.500076 V	8001
Midscale	2.5 V	8000
Midscale - 1 LSB	2.499924 V	7FFF
-FSR + 1 LSB	-76.29 μV	0001
-FSR	0 V	0000 ²

NOTES

¹This is also the code for overrange analog input ($V_{INx} - V_{INxN}$ above $2 \times (V_{REF} - V_{REFGND})$).

²This is also the code for underrange analog input (V_{INx} below V_{INxN}).

TYPICAL CONNECTION DIAGRAM

Figure 5 shows a typical connection diagram for the AD7654. Different circuitry shown on this diagram is optional and is discussed below.

Analog Inputs

Figure 4 shows a simplified analog input section of the AD7654.

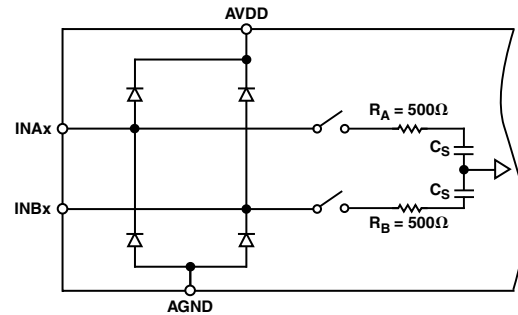

Figure 4. Simplified Analog Input

The diodes shown in Figure 4 provide ESD protection for the inputs. Care must be taken to ensure that the analog input signal never exceeds the absolute ratings on these inputs. This will cause these diodes to become forward-biased and start conducting current. These diodes can handle a forward-biased current of 120 mA maximum. This condition could eventually occur when the input buffer's (U1) or (U2) supplies are different from AVDD. In such case, an input buffer with a short-circuit current limitation can be used to protect the part.

This analog input structure allows the sampling of the differential signal between INx and $INxN$. Unlike other converters, the $INxN$ is sampled at the same time as the INx input. By using these differential inputs, small signals common to both inputs are rejected.

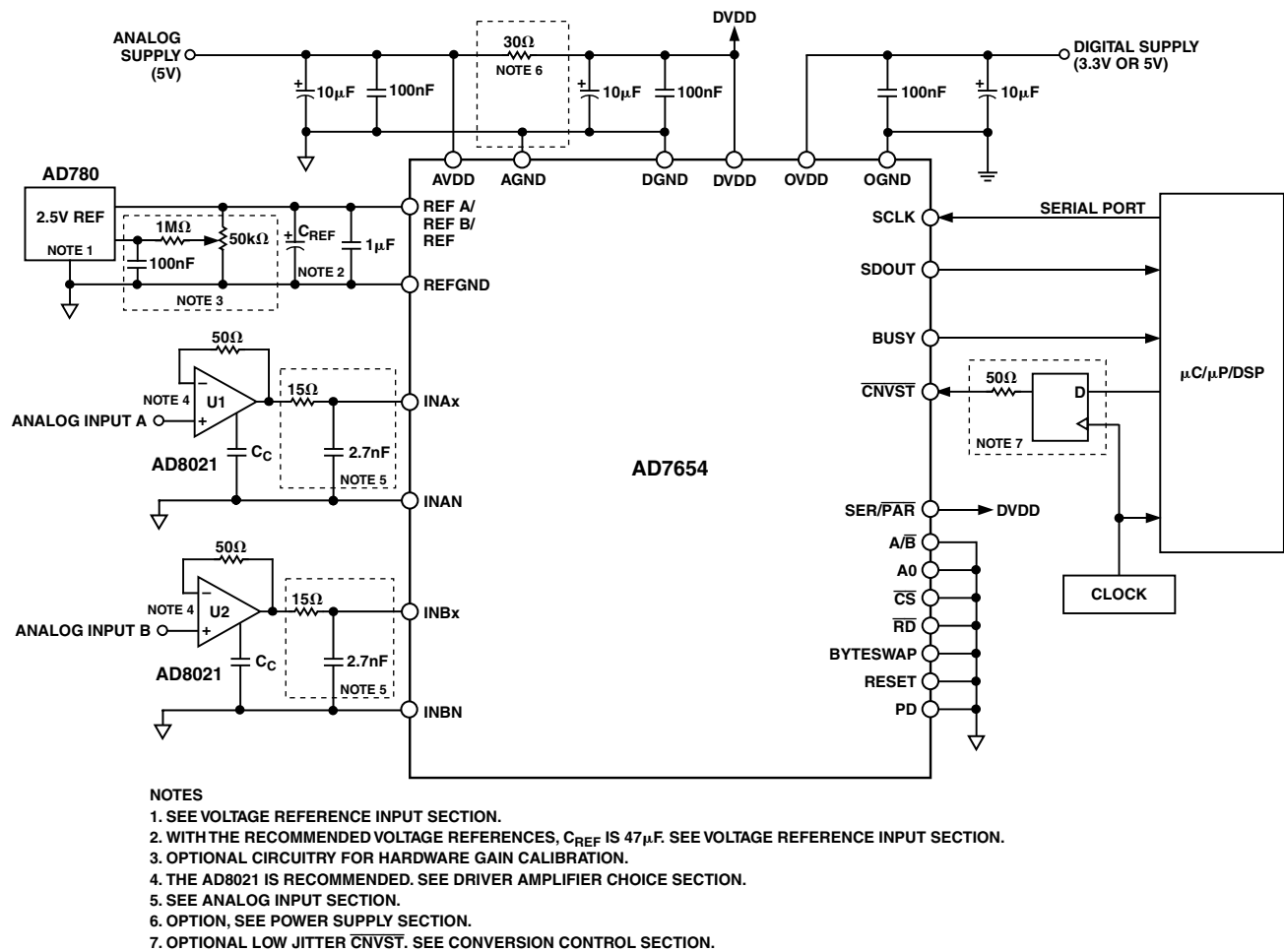

Figure 5. Typical Connection Diagram (Serial Interface)

During the acquisition phase, for ac signals, the AD7654 behaves like a one-pole RC filter consisted of the equivalent resistance R_A , R_B , and C_S . The resistors R_A and R_B are typically 500 Ω and are a lumped component made up of some serial resistor and the on resistance of the switches. The capacitor C_S is typically 32 pF and is mainly the ADC sampling capacitor. This one-pole filter with a typical -3 dB cutoff frequency of 10 MHz reduces undesirable aliasing effect and limits the noise coming from the inputs.

Because the input impedance of the AD7654 is very high, the AD7654 can be driven directly by a low impedance source without gain error. As shown in Figure 5 that allows the user to put an external one-pole RC filter between the output of the amplifier output and the ADC analog inputs to even further improve the noise filtering done by the AD7654 analog input circuit. However, the source impedance has to be kept low because it affects the ac performance, especially the total harmonic distortion. The maximum source impedance

depends on the amount of total harmonic distortion (THD) that can be tolerated. The THD degrades with increase of the source impedance.

Driver Amplifier Choice

Although the AD7654 is easy to drive, the driver amplifier needs to meet at least the following requirements:

- The driver amplifier and the AD7654 analog input circuit together have to be able to settle for a full-scale step of the capacitor array at a 16-bit level (0.0015%). In the amplifier's data sheet, the settling at 0.1% or 0.01% is more commonly specified. It could significantly differ from the settling time at a 16-bit level and, therefore, it should be verified prior to the driver selection. The tiny op amp AD8021, which combines ultralow noise and a high gain bandwidth, meets this settling time requirement even when used with a high gain of up to 13.

AD7654

- The noise generated by the driver amplifier needs to be kept as low as possible to preserve the SNR and transition noise performance of the AD7654. The noise coming from the driver is filtered by the AD7654 analog input circuit one-pole low-pass filter made by R_A , R_B , and C_S . The SNR degradation due to the amplifier is:

$$SNR_{LOSS} = 20 \log \left(\frac{56}{\sqrt{56^2 + \frac{\pi}{2} f_{-3dB} (N e_N)^2}} \right)$$

where:

f_{-3dB} is the -3 dB input bandwidth in MHz of the AD7654 (10 MHz) or the cutoff frequency of the input filter if any is used.

N is the noise factor of the amplifier (1 if in buffer configuration).

e_N is the equivalent input noise voltage of the op amp in $nV/\sqrt{Hz}^{1/2}$.

For instance, a driver with an equivalent input noise of $2 nV/\sqrt{Hz}$ like the AD8021 and configured as a buffer, thus with a noise gain of +1, will degrade the SNR by only 0.03 dB with the filter in Figure 5, and 0.09 dB without.

- The driver needs to have a THD performance suitable to that of the AD7654.

The AD8021 meets these requirements and is usually appropriate for almost all applications. The AD8021 needs an external compensation capacitor of 10 pF. This capacitor should have good linearity as an NPO ceramic or mica type.

The AD8022 could be used where a dual version is needed and a gain of 1 is used.

The AD829 is another alternative where high frequency (above 100 kHz) performance is not required. In a gain of 1, it requires an 82 pF compensation capacitor.

The AD8610 is another option where low bias current is needed in low frequency applications.

Voltage Reference Input

The AD7654 requires an external 2.5 V reference. The reference input should be applied to REFA and REFB. The voltage reference input REF of the AD7654 has a dynamic input impedance; it should therefore be driven by a low impedance source with an efficient decoupling. This decoupling depends on the choice of the voltage reference but usually consists of a 1 μ F ceramic capacitor and a low ESR tantalum capacitor connected to the REFA, REFB, and REFGND inputs with minimum parasitic inductance. 47 μ F is an appropriate value for the tantalum capacitor when using one of the recommended reference voltages:

- The low noise, low temperature drift AD780 voltage reference
- The low cost AD1582 voltage reference

For applications using multiple AD7654s, it is more effective to buffer the reference voltage using the internal buffer. Each ADC should be decoupled individually.

Care should be taken with the reference temperature coefficient of the voltage reference, which directly affects the full-scale accuracy if this parameter is applicable. For instance, a ± 15 ppm/ $^{\circ}C$ tempco of the reference changes the full-scale accuracy by ± 1 LSB/ $^{\circ}C$.

Power Supply

The AD7654 uses three sets of power supply pins: an analog 5 V supply AVDD, a digital 5 V core supply DVDD, and a digital input/output interface supply OVDD. The OVDD supply allows direct interface with any logic working between 2.7 V and DVDD + 0.3 V. To reduce the number of supplies needed, the digital core (DVDD) can be supplied through a simple RC filter from the analog supply, as shown in Figure 5. The AD7654 is independent of power supply sequencing, once OVDD does not exceed DVDD by more than 0.3 V, and thus free from supply voltage induced latchup. Additionally, it is very insensitive to power supply variations over a wide frequency range, as shown in Figure 6.

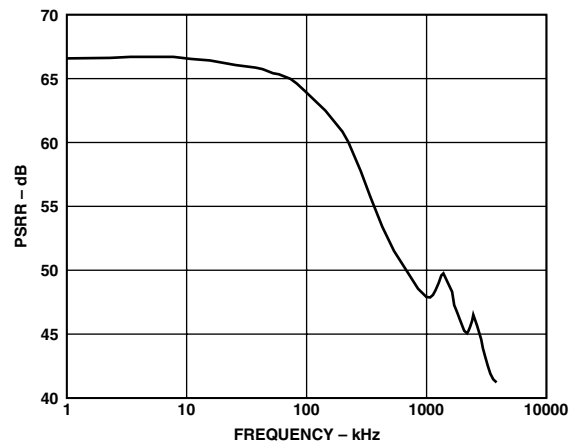

Figure 6. PSRR vs. Frequency

POWER DISSIPATION

In Impulse Mode, the AD7654 automatically reduces its power consumption at the end of each conversion phase. During the acquisition phase, the operating currents are very low, which allows significant power savings when the conversion rate is reduced, as shown in Figure 7. This feature makes the AD7654 ideal for very low power battery applications.

It should be noted that the digital interface remains active even during the acquisition phase. To reduce the operating digital supply currents even further, the digital inputs need to be driven close to the power rails (i.e., DVDD and DGND), and OVDD should not exceed DVDD by more than 0.3 V.

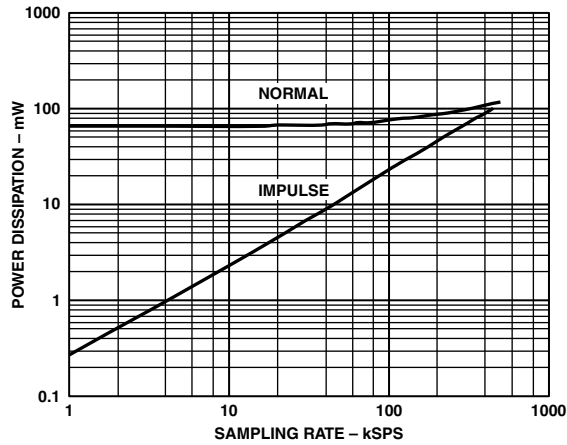

Figure 7. Power Dissipation vs. Sample Rate

CONVERSION CONTROL

Figure 8 shows the detailed timing diagrams of the conversion process. The AD7654 is controlled by the signal $\overline{\text{CNVST}}$, which initiates conversion. Once initiated, it cannot be restarted or aborted, even by the power-down input PD, until the conversion is complete. The $\overline{\text{CNVST}}$ signal operates independently of the $\overline{\text{CS}}$ and $\overline{\text{RD}}$ signals. The A0 signal is the MUX select signal that chooses which input signal will be sampled. When high, INx1 is chosen and when low, INx2 is chosen, where x is either A or B. It should be noted that this signal should not be changed during the acquisition phase of the converter.

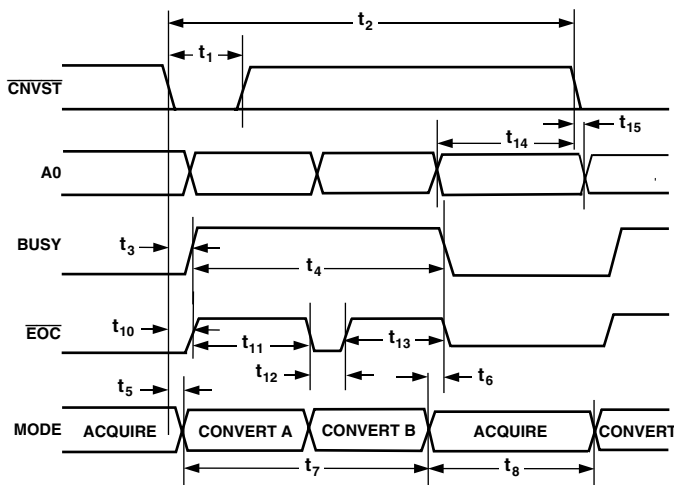

Figure 8. Conversion Control

In Impulse mode, conversions can be automatically initiated. If $\overline{\text{CNVST}}$ is held low when BUSY is low, the AD7654 controls the acquisition phase and automatically initiates a new conversion. By keeping $\overline{\text{CNVST}}$ low, the AD7654 keeps the

conversion process running by itself. It should be noted that the analog input has to be settled when BUSY goes low. Also, at power-up, $\overline{\text{CNVST}}$ should be brought low once to initiate the conversion process. In this mode, the AD7654 could sometimes run slightly faster than the guaranteed limits in the Impulse mode of 444 kSPS. This feature does not exist in Normal mode.

Although $\overline{\text{CNVST}}$ is a digital signal, it should be designed with special care with fast, clean edges and levels, and with minimum overshoot and undershoot or ringing.

For applications where the SNR is critical, the $\overline{\text{CNVST}}$ signal should have very low jitter. Some solutions to achieve this are to use a dedicated oscillator for $\overline{\text{CNVST}}$ generation or, at least, to clock it with a high frequency low jitter clock, as shown in Figure 5.

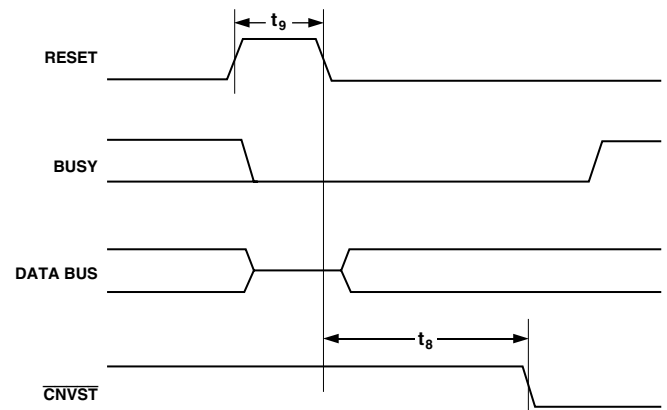

Figure 9. Reset Timing

DIGITAL INTERFACE

The AD7654 has a versatile digital interface; it can be interfaced with the host system by using either a serial or parallel interface. The serial interface is multiplexed on the parallel data bus. The AD7654 digital interface accommodates either 3 V or 5 V logic by simply connecting the OVDD supply pin of the AD7654 to the host system interface digital supply.

Signals $\overline{\text{CS}}$ and $\overline{\text{RD}}$ control the interface. When at least one of these signals is high, the interface outputs are in high impedance. Usually, $\overline{\text{CS}}$ allows the selection of each AD7654 in multicircuit applications and is held low in a single AD7654 design. $\overline{\text{RD}}$ is generally used to enable the conversion result on the data bus. In parallel mode, signal $\overline{\text{A/B}}$ allows the choice of reading either the output of channel A or channel B, whereas in serial mode, signal $\overline{\text{A/B}}$ controls which channel is output first.

AD7654

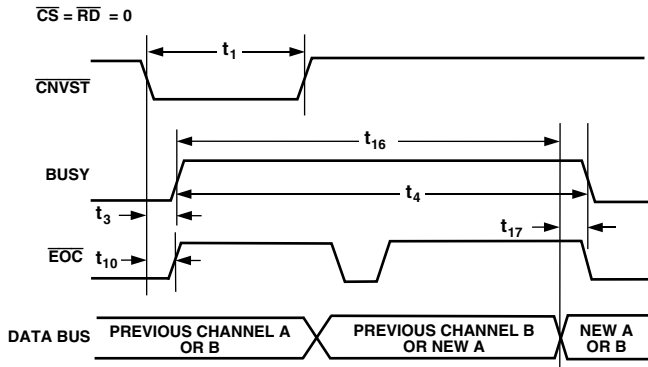

Figure 10. Master Parallel Data Timing for Reading (Continuous Read)

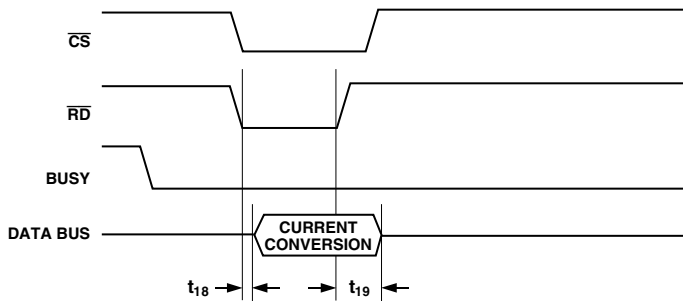

Figure 11. Slave Parallel Data Timing for Reading (Read after Convert)

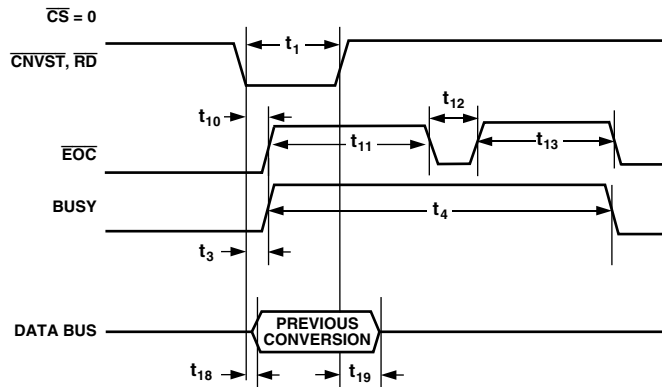

Figure 12. Slave Parallel Data Timing for Reading (Read during Convert)

PARALLEL INTERFACE

The AD7654 is configured to use the parallel interface (Figure 10) when the SER/PAR is held low. The data can be read either after each conversion, which is during the next acquisition phase or during the other channel's conversion, or during the following conversion as shown, respectively, in Figures 11 and 12. When the data is read during the conversion, however, it is recommended

that it is read only during the first half of the conversion phase. This avoids any potential feedthrough between voltage transients on the digital interface and the most critical analog conversion circuitry.

The BYTESWAP pin allows a glueless interface to an 8-bit bus. As shown in Figure 13, the LSB byte is output on D[7:0] and the MSB is output on D[15:8] when BYTESWAP is low. When BYTESWAP is high, the LSB and MSB bytes are swapped, the LSB is output on D[15:8], and the MSB is output on D[7:0]. By connecting BYTESWAP to an address line, the 16-bit data can be read in two bytes on either D[15:8] or D[7:0].

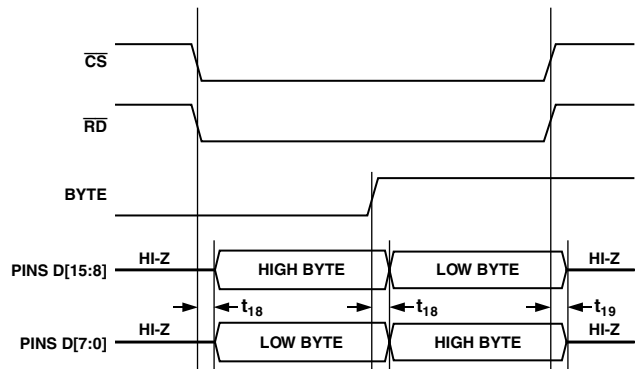

Figure 13. 8-Bit Parallel Interface

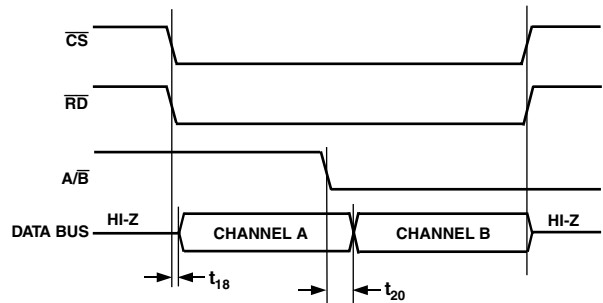

Figure 14. A/B Channel Reading

The detailed functionality of A/B is explained in Figure 15. When high, the data from channel A is available on the data bus. When low, the data bus now carries output from channel B. Note that channel A can be read immediately after conversion is done (EOC), while channel B is still in its converting phase.

SERIAL INTERFACE

The AD7654 is configured to use the serial interface when the SER/PAR is held high. The AD7654 outputs 32 bits of data, MSB first, on the SDOUT pin. The order of the channels being output is controlled by A/B. When high, channel A is output first; when low, channel B is output first. Unlike in parallel

mode, channel A data is updated only after channel B conversion. This data is synchronized with the 32 clock pulses provided on the SCLK pin.

MASTER SERIAL INTERFACE

Internal Clock

The AD7654 is configured to generate and provide the serial data clock SCLK when the EXT/ $\overline{\text{INT}}$ pin is held low. The AD7654 also generates a SYNC signal to indicate to the host when the serial data is valid. The serial clock SCLK and the SYNC signal can be inverted if desired. The output data is valid on both the rising and falling edge of the data clock. Depending on RDC/SDIN input, the data can be read after each conversion or during the following conversion.

Figures 15 and 16 show the detailed timing diagrams of these two modes.

Usually, because the AD7654 is used with a fast throughput, the mode Master Read during Conversion is the most recommended serial mode when it can be used.

In Read-after-Conversion Mode, it should be noted that unlike in other modes, the signal BUSY returns low after the 32 data bits are pulsed out and not at the end of the conversion phase, which results in a longer BUSY width. One advantage of this mode is that it can accommodate slow digital hosts because the serial clock can be slowed down by using DIVSCLK.

In Read-during-Conversion Mode, the serial clock and data toggle at appropriate instants, which minimizes potential feedthrough

between digital activity and the critical conversion decisions. The SYNC signal goes low after the LSB of each channel has been output.

SLAVE SERIAL INTERFACE

External Clock

The AD7654 is configured to accept an externally supplied serial data clock on the SCLK pin when the EXT/ $\overline{\text{INT}}$ pin is held high. In this mode, several methods can be used to read the data. The external serial clock is gated by $\overline{\text{CS}}$ and the data are output when both $\overline{\text{CS}}$ and $\overline{\text{RD}}$ are low. Thus, depending on $\overline{\text{CS}}$, the data can be read after each conversion or during the following conversion. The external clock can be either a continuous or discontinuous clock. A discontinuous clock can be either normally high or normally low when inactive. Figures 17 and 18 show the detailed timing diagrams of these methods.

While the AD7654 is performing a bit decision, it is important that voltage transients not occur on digital input/output pins or degradation of the conversion result could occur. This is particularly important during the second half of the conversion phase of each channel because the AD7654 provides error correction circuitry that can correct for an improper bit decision made during the first half of the conversion phase. For this reason, it is recommended that when an external clock is provided, it is a discontinuous clock that is toggling only when BUSY is low or, more importantly, that it does not transition during the latter half of EOC high.

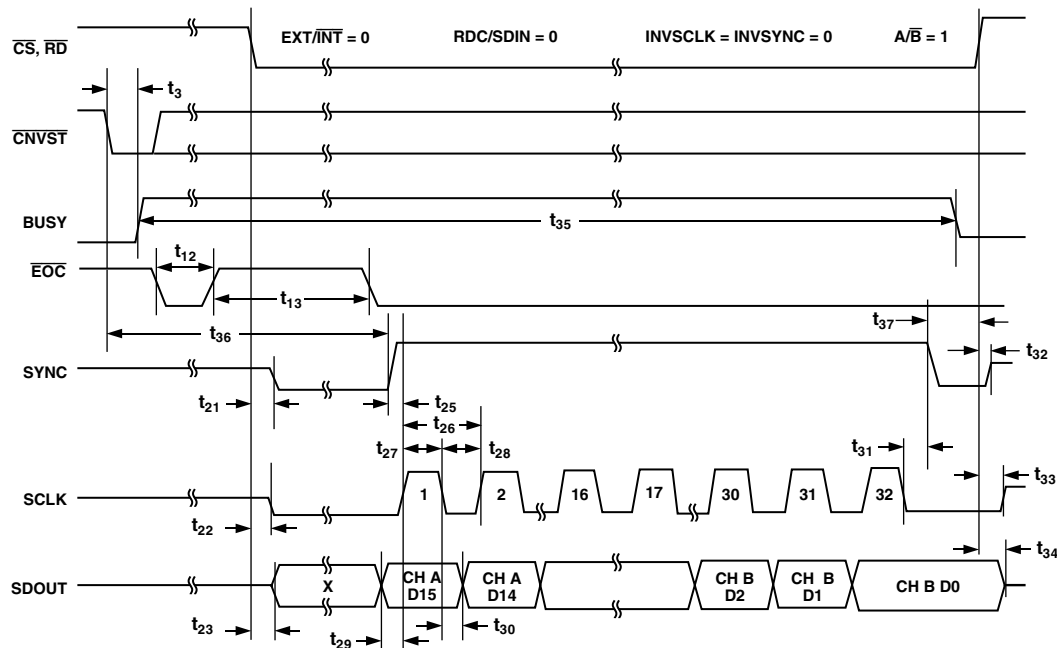

Figure 15. Master Serial Data Timing for Reading (Read after Convert)

AD7654

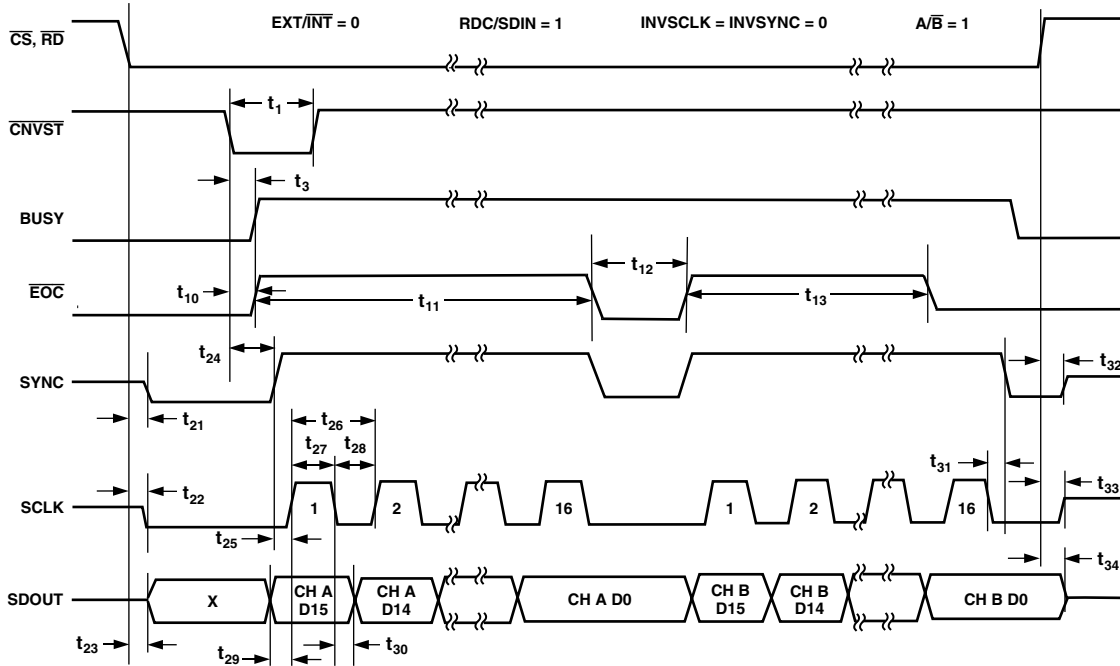

Figure 16. Master Serial Data Timing for Reading (Read Previous Conversion during Convert)

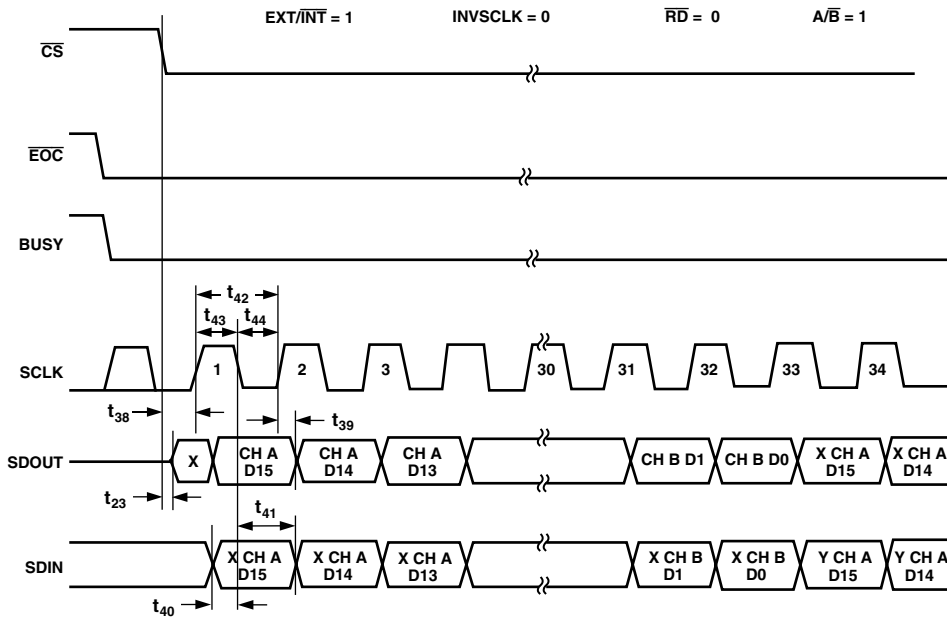

Figure 17. Slave Serial Data Timing for Reading (Read after Convert)

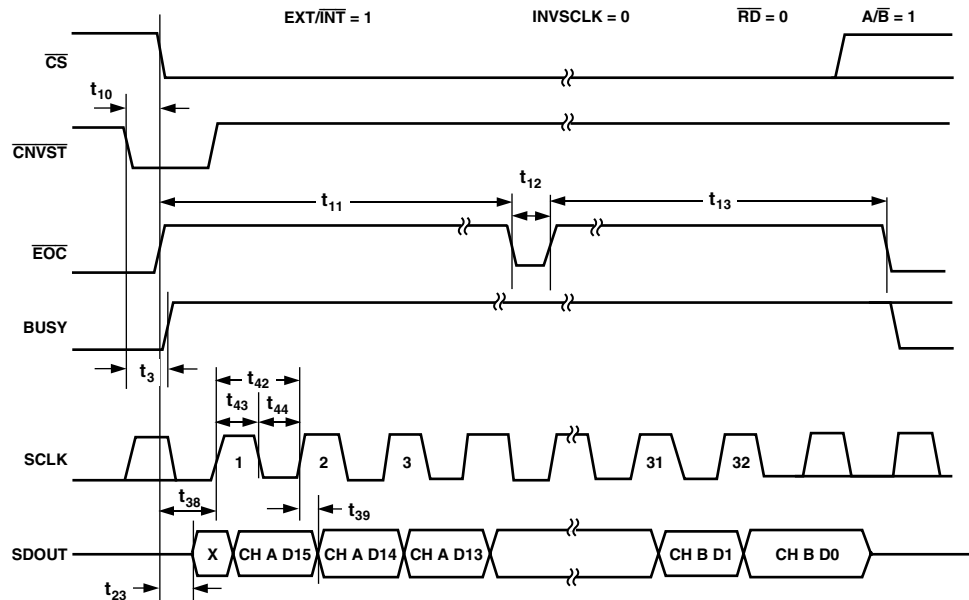

Figure 18. Slave Serial Data Timing for Reading (Read Previous Conversion during Convert)

External Discontinuous Clock Data Read after Conversion

This mode is the most recommended of the serial slave modes. Figure 18 shows the detailed timing diagrams of this method. After a conversion is complete, indicated by $BUSY$ returning low, the results of this conversion can be read while both \overline{CS} and \overline{RD} are low. The data from both channels are shifted out, MSB first, with 32 clock pulses, and is valid on both rising and falling edge of the clock.

One advantage of this method is that the conversion performance is not degraded because there are no voltage transients on the digital interface during the conversion process.

Another advantage is to be able to read the data at any speed up to 40 MHz, which accommodates both slow digital host interface and the fastest serial reading.

Finally, in this mode only, the AD7654 provides a daisy-chain feature using the $RDC/SDIN$ input pin for cascading multiple converters together. This feature is useful for reducing component count and wiring connections when it is desired, as it is for instance, in isolated multiconverters applications.

An example of the concatenation of two devices is shown in Figure 19. Simultaneous sampling is possible by using a common $CNVST$ signal. It should be noted that the $RDC/SDIN$ input is latched on the edge of $SCLK$ opposite the one used to shift out the data on $SDOUT$. Therefore, the MSB of the upstream converter follows the LSB of the downstream converter on the next $SCLK$ cycle.

External Clock Data Read during Conversion

Figure 18 shows the detailed timing diagrams of this method. During a conversion, while both \overline{CS} and \overline{RD} are low, the result of the previous conversion can be read. The data is shifted out, MSB first, with 32 clock pulses, and is valid on both rising and falling edges of the clock. The 32 bits have to be read before the current conversion is complete. If that is not done, $RDERROR$ is pulsed high and can be used to interrupt the host interface to prevent incomplete data reading. There is no daisy-chain feature in this mode, and $RDC/SDIN$ input should always be tied either high or low.

To reduce performance degradation due to digital activity, a fast discontinuous clock is recommended to ensure that all the bits are read during the first half of the conversion phase. It is also possible to begin to read the data after conversion and continue to read the last bits even after a new conversion has been initiated.

AD7654

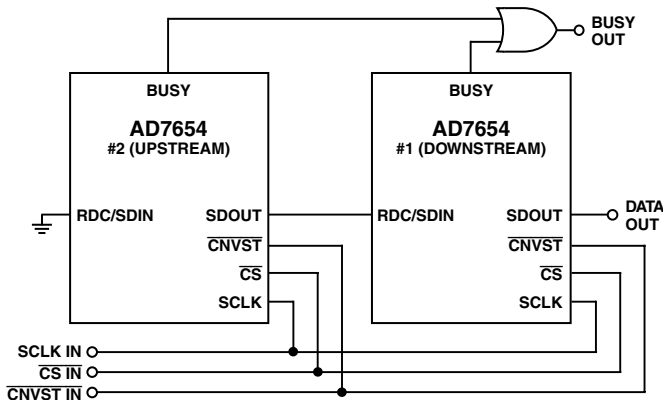

Figure 19. Two AD7654s in a Daisy-Chain Configuration

MICROPROCESSOR INTERFACING

The AD7654 is ideally suited for traditional dc measurement applications supporting a microprocessor, and for ac signal processing applications interfacing to a digital signal processor. The AD7654 is designed to interface with either a parallel 8-bit or 16-bit wide interface, a general-purpose serial port, or I/O ports on a microcontroller. A variety of external buffers can be used with the AD7654 to prevent digital noise from coupling into the ADC. The following section illustrates the use of the AD7654 with an SPI-equipped DSP, the ADSP-219x.

SPI Interface (ADSP-219x)

Figure 19 shows an interface diagram between the AD7654 and an SPI-equipped DSP, ADSP-219x. To accommodate the slower speed of the DSP, the AD7654 acts as a slave device and data must be read after conversion. This mode also allows the daisy-chain feature. The convert command can be initiated in response to an internal timer interrupt. The 32-bit output data are read with two SPI 16-bit wide access. The reading process could be initiated in response to the end-of-conversion signal (BUSY going low) using an interrupt line of the DSP. The Serial Peripheral Interface (SPI) on the ADSP-219x is configured for master mode (MSTR) = 1, Clock Polarity Bit (CPOL) = 0, and Clock Phase Bit (CPHA) = 1 by writing to the SPI Control Register (SPICLTx).

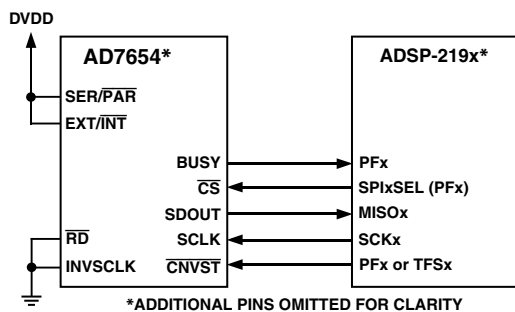

Figure 20. Interfacing the AD7654 to SPI Interface

APPLICATION HINTS

Layout

The AD7654 has very good immunity to noise on the power supplies, as seen in Figure 5. However, care should still be taken with regard to grounding layout.

The printed circuit board that houses the AD7654 should be designed so the analog and digital sections are separated and confined to certain areas of the board. This facilitates the use of

ground planes that can be easily separated. Digital and analog ground planes should be joined in only one place, preferably underneath the AD7654, or, at least as close as possible to the AD7654. If the AD7654 is in a system where multiple devices require analog-to-digital ground connections, the connection should still be made at one point only, a star ground point that should be established as close as possible to the AD7654.

It is recommended to avoid running digital lines under the device as these will couple noise onto the die. The analog ground plane should be allowed to run under the AD7654 to avoid noise coupling. Fast switching signals like CNVST or clocks should be shielded with digital ground to avoid radiating noise to other sections of the board, and should never run near analog signal paths. Crossover of digital and analog signals should be avoided. Traces on different but close layers of the board should run at right angles to each other. This will reduce the effect of feedthrough through the board. The power supply lines to the AD7654 should use as large a trace as possible to provide low impedance paths and reduce the effect of glitches on the power supply lines. Good decoupling is also important to lower the supply's impedance presented to the AD7654 and to reduce the magnitude of the supply spikes. Decoupling ceramic capacitors, typically 100 nF, should be placed on each power supply's pins, AVDD, DVDD, and OVDD, close to and ideally right up against these pins and their corresponding ground pins. Additionally, low ESR 10 µF capacitors should be located in the vicinity of the ADC to further reduce low frequency ripple.

The DVDD supply of the AD7654 can be either a separate supply or come from the analog supply, AVDD, or from the digital interface supply, OVDD. When the system digital supply is noisy or fast switching digital signals are present, it is recommended that if no separate supply is available, the DVDD digital supply should be connected to the analog supply AVDD through an RC filter, as shown in Figure 5, and the system supply should be connected to the interface digital supply OVDD and the remaining digital circuitry. When DVDD is powered from the system supply, it is useful to insert a bead to further reduce high frequency spikes.

The AD7654 has four different ground pins: REFGND, AGND, DGND, and OGND. REFGND senses the reference voltage and should be a low impedance return to the reference because it carries pulsed currents. AGND is the ground to which most internal ADC analog signals are referenced. This ground must be connected with the least resistance to the analog ground plane. DGND must be tied to the analog or digital ground plane depending on the configuration. OGND is connected to the digital system ground.

The layout of the decoupling of the reference voltage is important. The decoupling capacitor should be close to the ADC and connected with short and large traces to minimize parasitic inductances.

Evaluating the AD7654's Performance

A recommended layout for the AD7654 is outlined in the documentation of the evaluation board for the AD7654. The evaluation board package includes a fully assembled and tested evaluation board, documentation, and software for controlling the board from a PC via the Eval-Control BRD2.

OUTLINE DIMENSIONS

48-Lead Plastic Quad Flatpack [LQFP]
1.4mm Thick
(ST-48)

Dimensions shown in millimeters

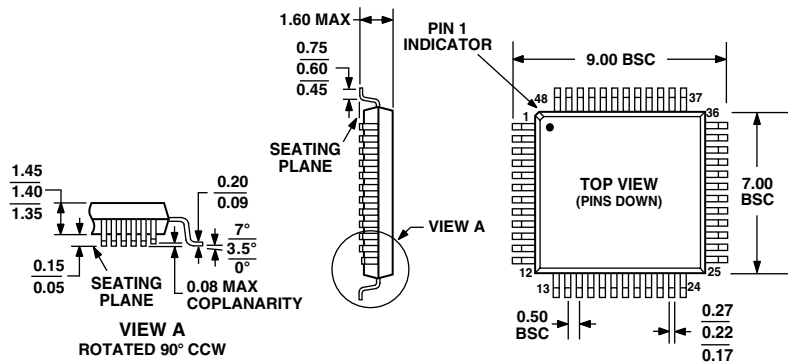

48-Lead Frame Chip Scale Package [LFCSP]
(CP-48)

Dimensions shown in millimeters

