



M/A-COM

Digital Attenuator, 4 Bit, Single Control 30 dB, 0.5 - 2.0 GHz



Features

- Single Control CMOS logic for each bit
- Attenuation 2 dB steps to 30 dB
- Low DC Power Consumption: 50 uW
- Low Cost Plastic TSSOP-16 Package

Description

The M/A-COM AT-264 is a 4 bit, 2 dB step GaAs MMIC digital attenuator in a low cost TSSOP-16 surface mount plastic package. The AT-264 is ideally suited for use where high accuracy, very low power consumption and low intermodulation products are required. Typical applications include radio, cellular, wireless LANs, GPS equipment and other gain/level control circuits.

The AT-264 is fabricated using a mature 1 micron GaAs MESFET process. The process features full chip passivation for increased performance and reliability.

TSSOP-16¹

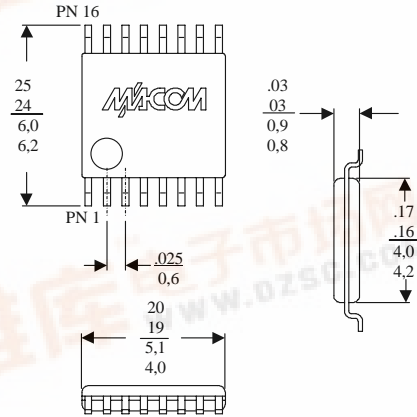

1. Dimensions are in inches/mm.

Ordering Information

Part Number	Package
AT-264	TSSOP 16-Lead Plastic
AT-264TR	Tape and Reel ¹

1. Refer to Application Note M513 for reel size information.

Electrical Specifications: T_A = +25°C¹

Parameter	Test Conditions	Units	Min.	Typ.	Max.
Reference Insertion Loss	0.5 - 1.0 GHz	dB		1.6	1.8
	0.5 - 2.0 GHz	dB		1.8	2.0
Attenuation Accuracy	0.5 - 1.0 GHz	±(0.15 dB + 5% of Attenuation setting in dB) dB			
	0.5 - 2.0 GHz	±(0.3 dB + 5% of Attenuation setting in dB) dB			
VSWR	1.0 - 1.5 GHz			1.5:1	
	0.5 - 2.0 GHz			1.9:1	
T _{rise} , T _{fall} T _{on} , T _{off} Transients	10% to 90% RF, 90% to 10% RF	μS		3	
	50% Control to 90% RF, 50% Control to 10% RF	μS		3	
	in Band	mV		75	
1 dB Compression	Input Power 0.5 GHz	dBm		25	
	Input Power 0.9 GHz	dBm		25	
IP ₂	Measured Relative to Input Power ² 0.5 GHz	dBm		65	
	0.5 - 2.0 GHz	dBm		71	
IP ₃	Measured Relative to Input Power ² 0.5 GHz	dBm		43	
	0.5 - 2.0 GHz	dBm		47	

1. All measurements at 900 MHz in a 50Ω system unless otherwise specified. Loss varies at 0.003 dB/°C.
 2. For two-tone Input Power up to +5 dBm.



Absolute Maximum Ratings¹

Parameter	Absolute Maximum
Input Power	
50 MHz	+27 dBm
500 - 2000 MHz	+34 dBm
Control Voltage	+8.5V, -0.5V
Operating Temperature	-40°C to +85°C
Storage Temperature	-65°C to +150°C

1. Exceeding any one or a combination of these limits may cause permanent damage.

Truth Table

VC1	VC2	VC3	VC4	Attenuation (dB)
1	1	1	1	Reference I.L.
1	1	1	0	2
1	1	0	1	4
1	0	1	1	8
0	1	1	1	16
0	0	0	0	30

Logic 0=0±0.2V

Logic 1 = +5v @ 30 µA max. current total.

Functional Schematic^{1,2}

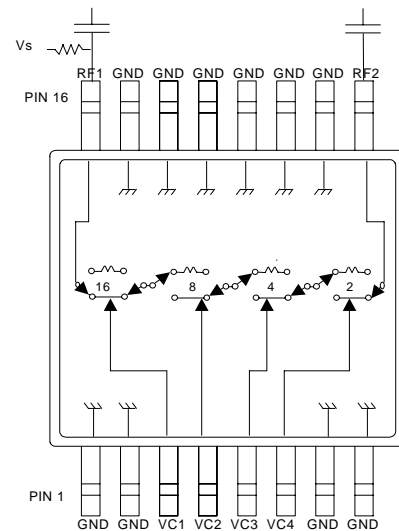

1. Blocking Caps are required on all RF ports, 39 pF used for data measurements.
2. Vs = +5±0.2Vdc can be applied at RF1 or RF2 using a 10K or greater pull-up resistor.

Typical Performance Curves

Insertion Loss vs. Frequency

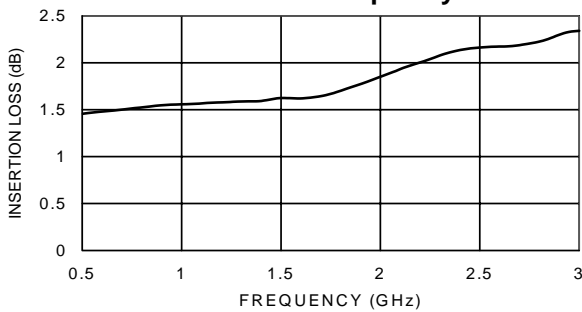

VSWR vs. Frequency

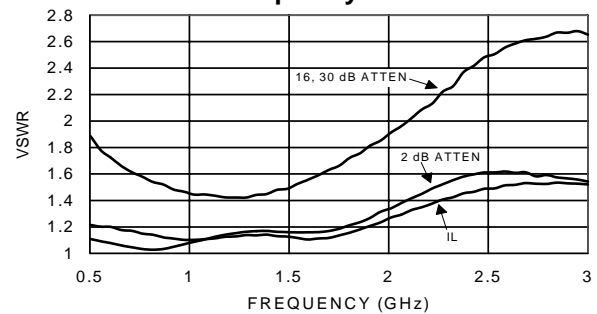

Attenuation vs. Frequency

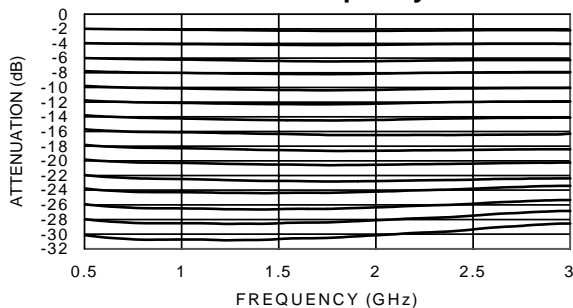

Attenuation Accuracy vs. Frequency

