



# ATS266

## High Voltage Hall Effect Latch

### ■ Features

- On-chip Hall plate
- Operating voltage: 4V~28V
- Output current: 400mA(Continuous)
- Reverse protection diode only for chip reverse power connecting <sup>(Note)</sup>
- Output protection Zener breakdown Vz=56V(Typ)
- Package: SIP-4L

(Note)

Protection diode only exists at power pin(1,4) output, not including pin (2,3).

### ■ Application

- Dual-coil Brush-less DC Motor
- Dual-coil Brush-less DC Fan
- Revolution Counting
- Speed Measurement

### ■ Pin Assignment

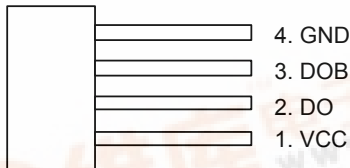

### ■ General Description

ATS266 is an integrated Hall sensor with output drivers designed for electronic commutation of brush-less DC motor applications. The device includes an on-chip Hall voltage generator for magnetic sensing, a comparator that amplifies the Hall voltage, and a Schmitt trigger to provide switching hysteresis for noise rejection, and complementary darlington open-collector drivers for sinking large current loads. An internal bandgap regulator is used to provide temperature compensated supply voltage for internal circuits and allows a wide operating supply range.

If a magnetic flux density (B) is larger than operate point (Bop), DO turn on (low) and DOB turn off (high). The outputs state is latched prior to release point (Brp) coming. if B < Brp, DO turn off and DOB turn on. ATS266 is rated for operation over temperature range from -20°C to 85°C and voltage range from 4.0V to 28V. The devices are available in low cost die forms or rugged 4 pin SIP packages.

### ■ Pin Configuration

Name	Description
VCC	Positive Power Supply
DO	Output Pin
DOB	Output Pin
GND	Ground

### ■ Ordering Information

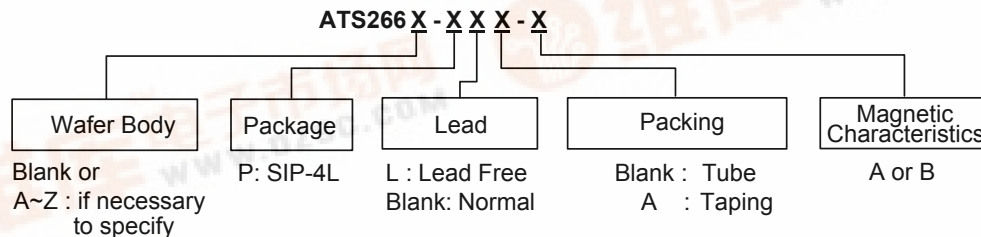

## High Voltage Hall Effect Latch

### ■ Block Diagram

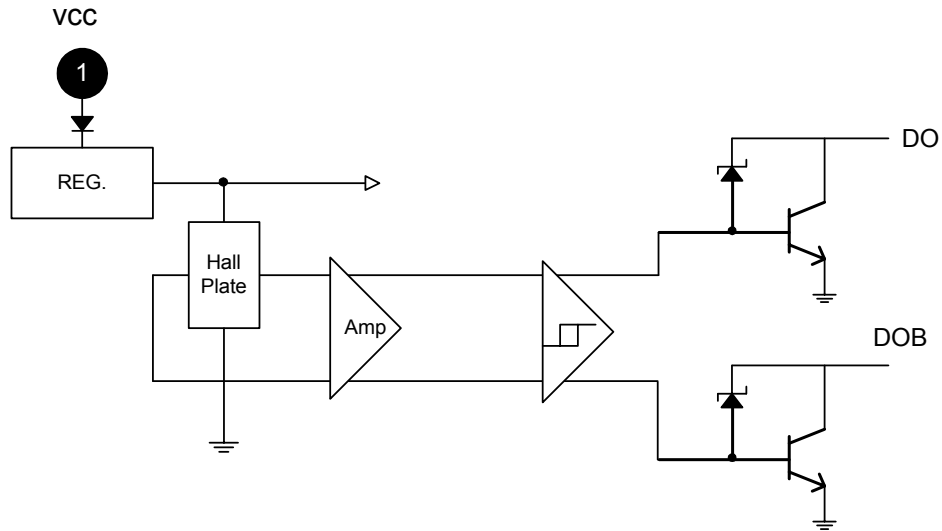

### ■ Application Circuit

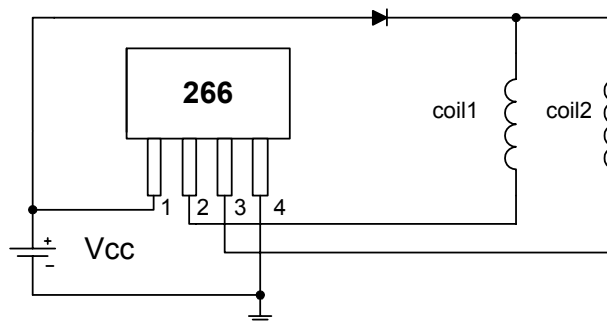

Brush-less DC Fan

Note: This application circuit can't protect reverse coil current if power is connecting reverse.

## High Voltage Hall Effect Latch

### ■ Absolute Maximum Ratings (at Ta = 25°C )

Parameter	Symbol	Rating	Unit
Supply voltage	VCC	28	V
Output "OFF" voltage	Vout (off)	20	V
Output "ON" current	Io (con)	400	mA
	Io (hold)	500	mA
	Io (peak)	700	mA
Magnetic flux density	B	Unlimited	Gauss
Operating temperature range	Top	-20~+85	°C
Storage temperature range	Tstg	-65~+150	°C
Power dissipation <sup>(Note)</sup>	PD	550	mW

Note: See Performance Characteristic for other conditions

### ■ Electrical Characteristics ( Ta = 25°C )

Characteristic	Symbol	Conditions	Min	Typ	Max	Unit
Supply Voltage	Vcc	—	4.0	—	28	V
Output Zener Breakdown	Vz	Output Turn off	—	56	—	V
Output Saturation Voltage	Vce(sat)	Vcc=14V, Ic=400mA	—	1.0	1.5	V
Output Leakage Current	Icex	Vce=14V, Vcc=14V	—	< 0.1	10	μA
Supply Current	Icc	Vcc=20V, Output Open	—	10	15	mA
Output Rise Time	Tr	Vcc=14V, RL=820Ω, CL=20pF	—	1.0	5	μs
Output Falling Time	tf	Vcc=14V, RL=820Ω, CL=20pF	—	1.0	1.5	μs
Switch Time Differential	Δt	Vcc=14V, RL=820Ω, CL=20pF	—	3.0	10	μs

### ■ Test Circuit

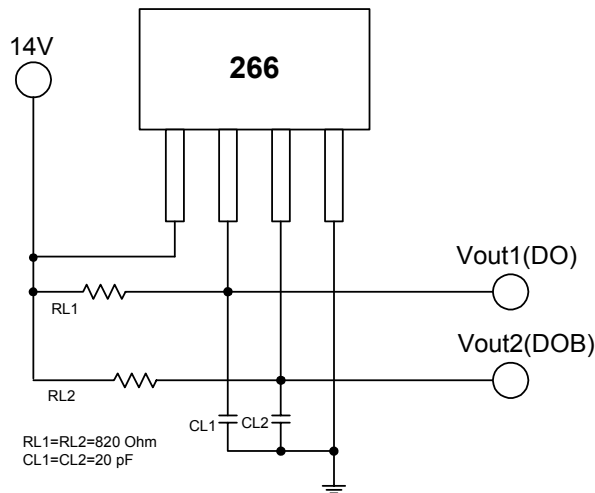

## High Voltage Hall Effect Latch

### ■ Magnetic Characteristics (Ta=+25°C)

(1mT=10Gauss)

#### A grade

Characteristic	Symbol	Min.	Typ.	Max.	Unit
Operate Point	Bop	10	-	70	Gauss
Release Point	Brp	-70	-	-10	Gauss
Hysteresis	Bhy	-	80	-	Gauss

#### B grade

Characteristic	Symbol	Min.	Typ.	Max.	Unit
Operate Point	Bop	-	-	100	Gauss
Release Point	Brp	-100	-	-	Gauss
Hysteresis	Bhy	-	80	-	Gauss

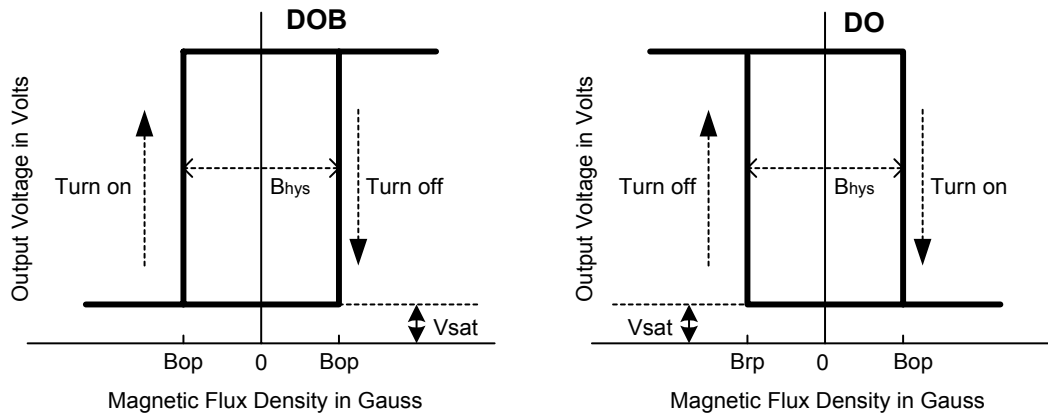

### ■ Performance Characteristics (SIP4)

Ta (°C)	25	50	60	70	80	85	90	95	100	105	110	115	120
Pd (mW)	550	440	396	352	308	286	264	242	220	198	176	154	132

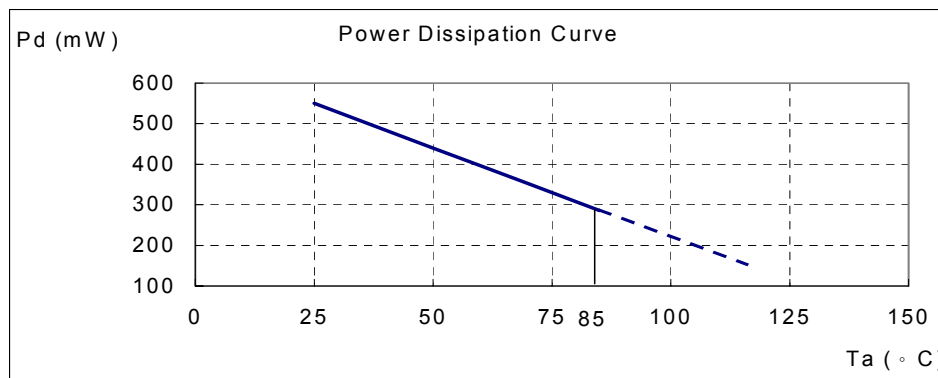

## High Voltage Hall Effect Latch

### ■ Operation Characteristics

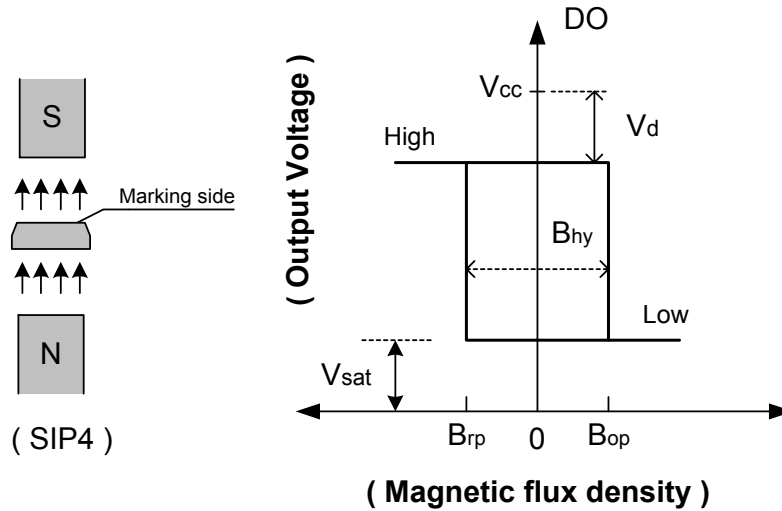

### ■ Marking Information

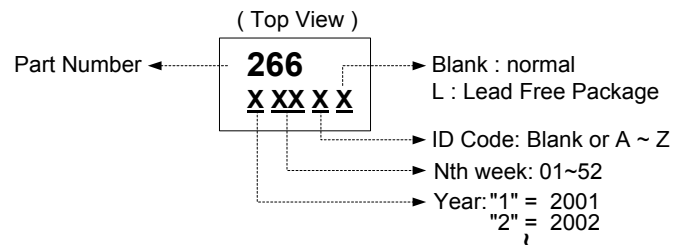

## High Voltage Hall Effect Latch

### ■ Package Information

Active Area Depth

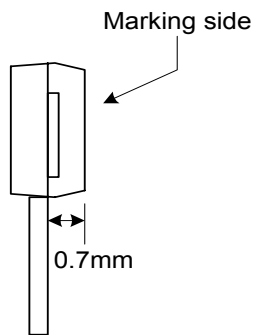

Package Sensor Location

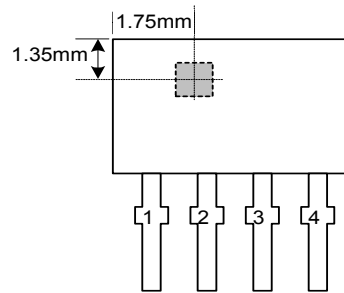

Package Dimension

