



Single Phase Hall Effect Latch

ATS477

■ Features

- On-chip Hall sensor
- Bi-direction H type output drivers for single coil
- Internal bandgap regulator allows temperature compensated operations and a wide operating voltage range
- High output sinking capability up to 250mA
- Operating voltage: 3.5V~20V
- Low output switching current noise
- Build-in shunt Zener protection for output driver
- SOP-7L provide FG output pin
- Package: SIP-4L and SOP-7L

■ Applications

- Single-coil Brush-less DC Fan
- Single-coil Brush-less DC Motor

■ General Description

ATS477 that integrates Hall sensor with output drivers is designed for electrical commutation of brush-less DC motor application. The device includes on-chip Hall voltage generator for magnetic sensing, the error amplifier that amplifies the Hall voltage, a comparator that is to provide switching hysteresis for noise rejection, the bi-direction drivers for sinking and driving large current load, and the frequency generator (FG) that provides a signal proportional to rotation speed. Internal bandgap regulator is used to provide temperature compensated bias for internal circuits and allows a wide operating supply voltage range. Built-in protection circuit and output shunt Zener diodes were applied for protecting output drivers during operating.

If a magnetic flux density is larger than threshold Bop, DO is turned to sink and DOB is turned to drive. The output state is held until a magnetic flux density reversal falls below Brp causing DO to be turned to drive and DOB turned to sink.

ATS477 is rated for operation over-temperature range from -20°C to 85°C and voltage range from 3.5V to 20V. The devices are available in low cost die forms or rugged SIP-4L and power SOP-7L packages.

■ Ordering Information

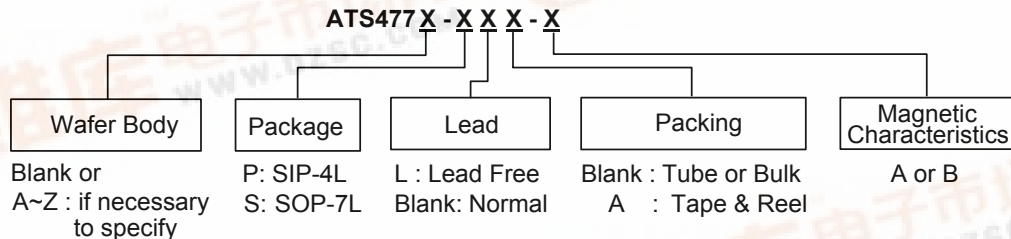

■ Application Circuit

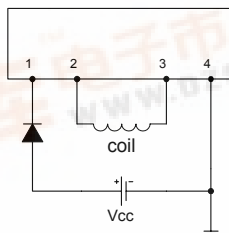

(SIP-4L)

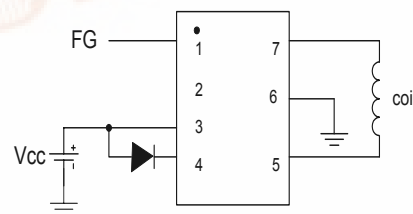

(SOP 7)

Single-coil brush-less DC Fan

■ **Pin Configuration**

(1)SIP-4L

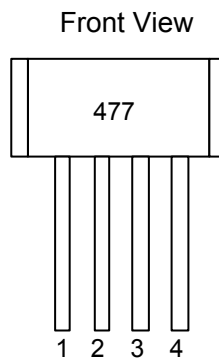

Name	P/I/O	Pin #	Description
Vcc	P	1	Positive Power Supply
DOB	O	2	Output Pin
DO	O	3	Output Pin
Vss	P	4	Ground

(2)SOP-7L

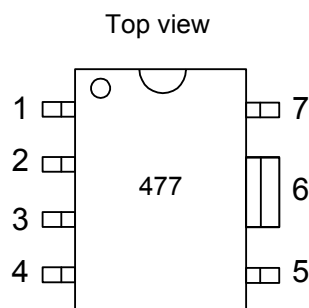

Name	P/I/O	Pin #	Description
Vcc	P	3,4	Positive Power Supply
DO	O	7	Output Pin
DOB	O	5	Output Pin
FG	O	1	Frequency Generator
Vss	P	6	Ground

■ Block Diagrams

(1). SIP-4L

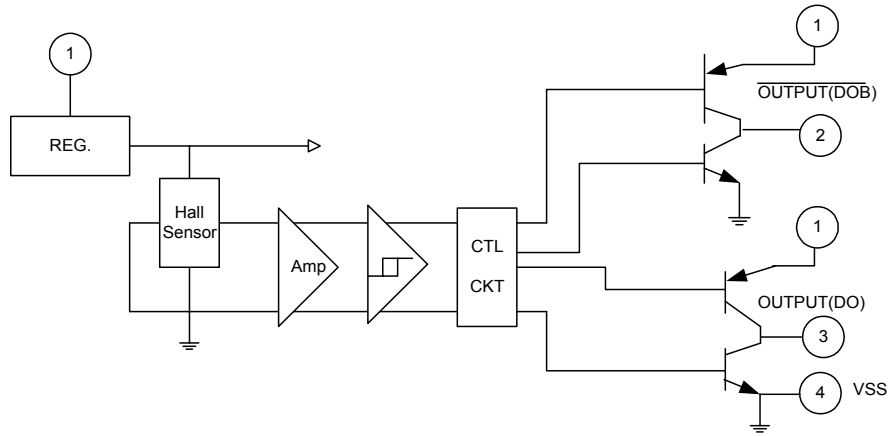

(2). SOP-7L

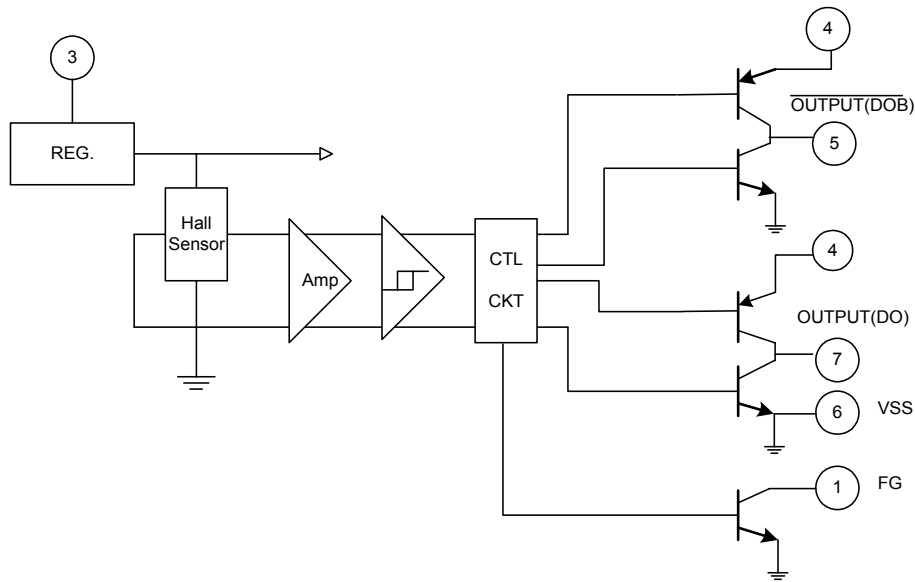



Single Phase Hall Effect Latch

ATS477

■ Absolute Maximum Ratings (at Ta=25°C)

Characteristics		Symbol	Values	Unit
Supply voltage		V _{CC}	20	V
Magnetic flux density		B	Unlimited	
Output "on" current	Continuous	I _c	250	mA
	Hold		300	
	Peak (Start Up)		600	
Operating temperature range		T _a	-20~+85	°C
Storage temperature range		T _s	-65~+150	°C
Package Power Dissipation	SIP-4L	PD	550	mW
	SOP-7L		800	mW (Note 1)

(Note 1) Ground pin must connect to large area copper on PCB as possible.

■ Electrical Characteristics (Ta=+25°C, V_{CC}=3.5V to 20V)

Characteristic	Symbol	Test Conditions	Min	Typ	Max	Unit
Supply Voltage	V _{CC}	—	3.5	—	20	V
Output Saturation Voltage	V _{ce(sink)}	V _{CC} =14V, I _c =200mA	—	500	800	mV
	V _{ce(drive)}	V _{CC} =14V, I _c =200mA	V _{CC} -1.5	—	V _{CC}	V
FG Saturation Voltage	V _{ce}	V _{CC} =14V, I _{FG} =20mA	—	0.3	0.7	V
Supply Current	I _{CC}	V _{CC} =20V, Output Open	—	18	30	mA
Output Rise Time	t _r	V _{CC} =14V, R _L =820Ω, C _L =20pF	—	1.0	5.0	μs
Output Falling Time	t _f	V _{CC} =14V, R _L =820Ω, C _L =20pF	—	0.3	1.5	μs
Switch Time Differential	Δt	V _{CC} =14V, R _L =820Ω, C _L =20pF	—	1.0	5.0	μs

■ Magnetic Characteristics (Ta=+25°C)

(1mT=10Gauss)

A grade

Characteristic	Symbol	Min.	Typ.	Max.	Unit
Operate Point	B _{op}	5	-	70	Gauss
Release Point	B _{rp}	-70	-	-5	Gauss
Hysteresis	B _{hy}	-	60	-	Gauss

B grade

Characteristic	Symbol	Min.	Typ.	Max.	Unit
Operate Point	B _{op}	-	-	100	Gauss
Release Point	B _{rp}	-100	-	-	Gauss
Hysteresis	B _{hy}	-	60	-	Gauss

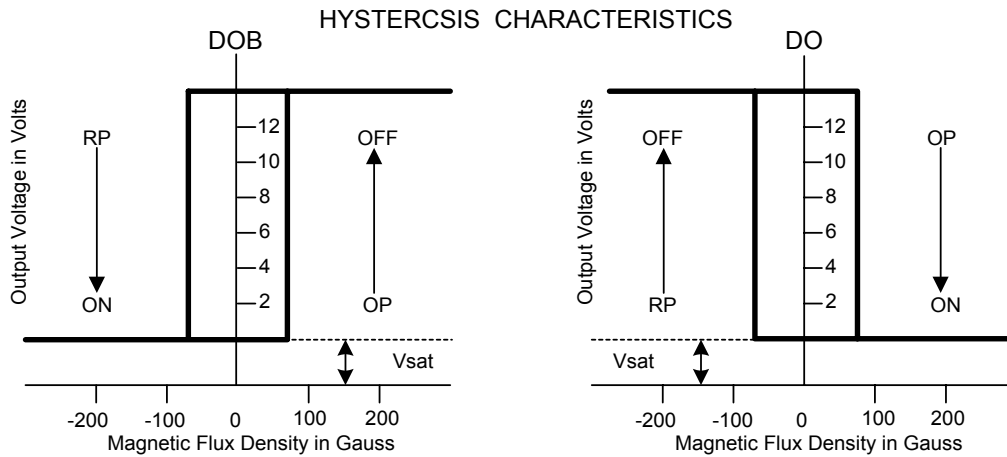

■ Operation Characteristics

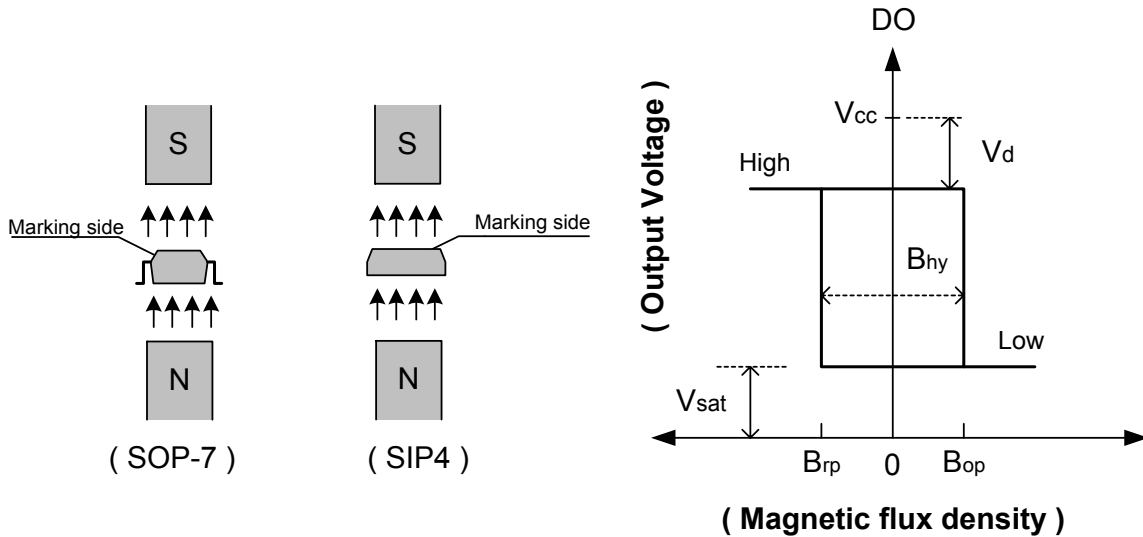

■ Marking Information

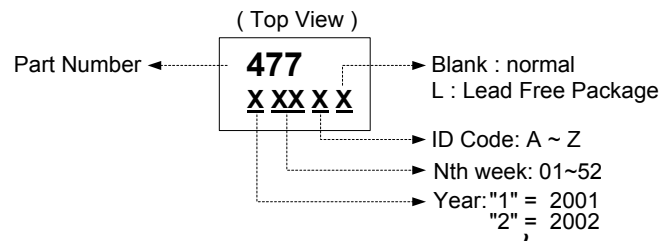

■ Package Information

(1) SIP-4L

Active Area Depth

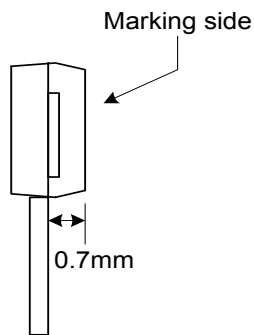

Package Sensor Location

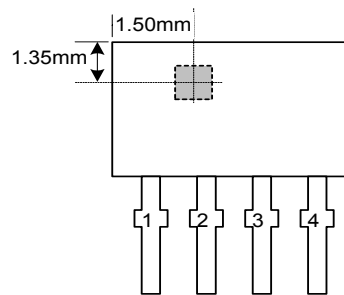

Package Dimension

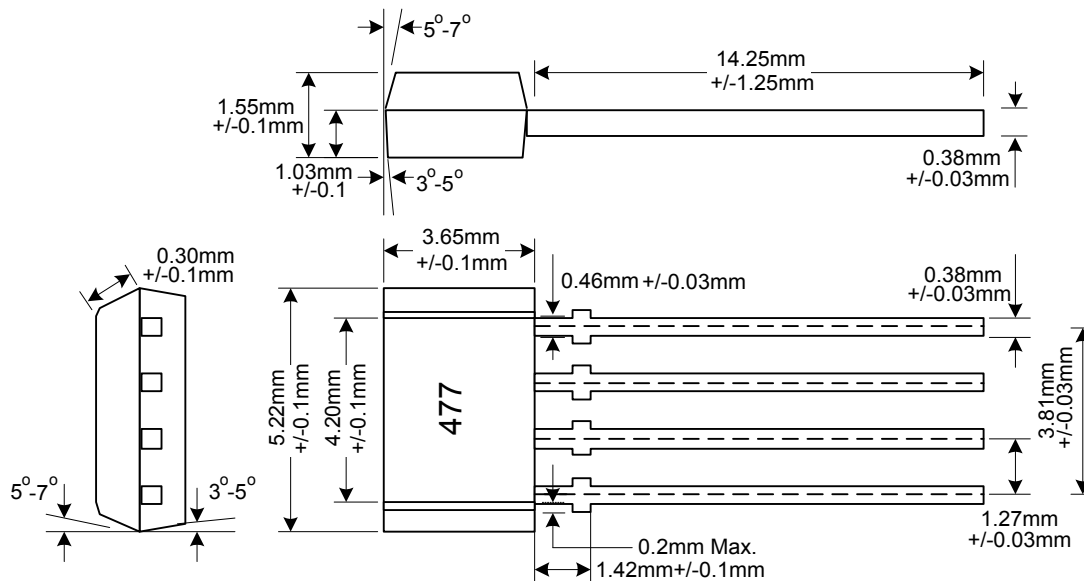

(2) SOP-7L

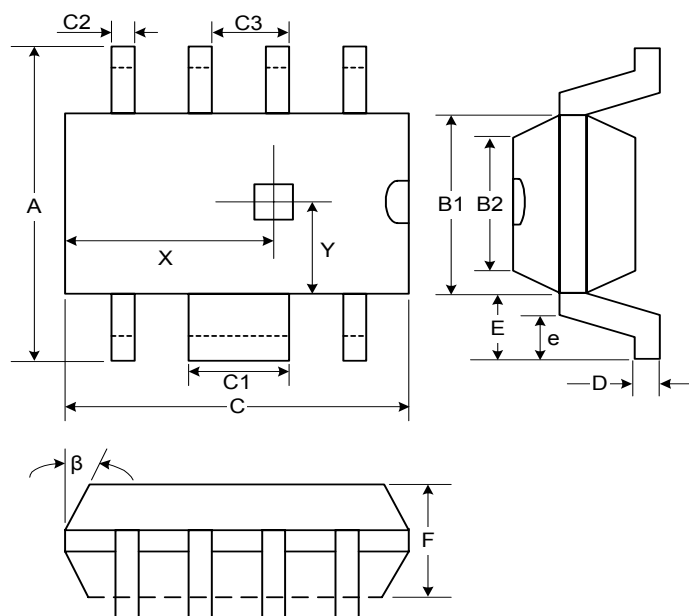

Symbol	Dimensions In Millimeters			Dimensions In Inches		
	Min.	Nom.	Max.	Min.	Nom.	Max.
A	5.79	5.99	6.19	0.228	0.236	0.244
B1	3.83	3.91	3.99	0.151	0.154	0.157
B2	3.78	3.86	3.94	0.149	0.152	0.155
C	4.80	4.87	4.94	0.189	0.192	0.194
C1	1.57	1.67	1.77	0.062	0.066	0.070
C2	0.32	0.40	0.48	0.013	0.016	0.019
C3	1.17	1.27	1.37	0.046	0.050	0.054
D	0.19	0.22	0.25	0.007	0.009	0.010
E	1.04REF			0.041REF		
e	0.48	0.68	0.88	0.019	0.027	0.035
F	1.35	1.45	1.55	0.053	0.057	0.061
X	-	2.90	-	-	0.114	-
Y	-	2.00	-	-	0.079	-
β	7°			7°		