

# HIP3™ Variable Attenuator

## 0.80–1.00 GHz

**Alpha**

AV111-12

### Features

- +40 dBm IP3 Typical
- Low Loss 1 dB Typical
- Attenuation 30 dB Typical
- Good VSWR <1.5:1 Typical
- Low Phase Shift

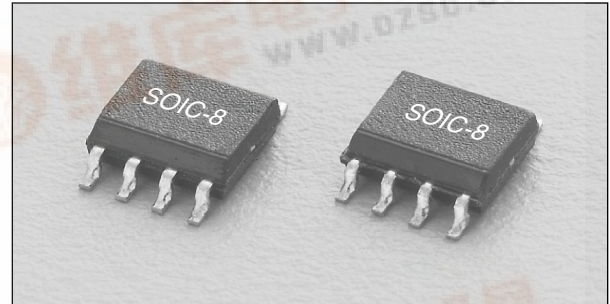

### Description

The AV111-12 is a current controlled variable attenuator from Alpha's series of HIP3™ components. It is designed to meet the wide dynamic range required in spread spectrum wireless base station applications. A monolithic quadrature hybrid is teamed with a silicon PIN diode pair in a plastic surface mount package reducing size and assuring consistency from part to part.

### Electrical Specifications at 25°C

Parameter	Min.	Typ.	Max.	Unit
Frequency	0.80		1.0	GHz
Insertion Loss (0 mA Control Current)		1.0	1.5	dB
Attenuation @ 1.2 mA Control Current (900 MHz)	17.5		21.5	dB
VSWR All Ports		1.5	1.8	
Input 3rd Order Intercept	+37	+40		dBm
Relative Phase Shift Up to 20 dB Attenuation <sup>1</sup>		7	10	Deg.
Group Delay		0.4	0.9	ns

### Operating Characteristics at 25°C (0, +5 V)

Parameter <sup>2</sup>	Condition	Frequency	Min.	Typ.	Max.	Unit
Switching Characteristics <sup>3</sup>	Rise, Fall (10/90% or 90/10% RF)				5	μs
	On, Off (50% CTL to 90/10% RF)				8	μs
	Video Feedthru (Peak)				5	mV
Maximum Input Power for <1 dB Attenuation Variation					+15	dBm

1. When built with external components as shown in the Pin Out diagram.
2. All measurements made in a 50 Ω system, unless otherwise specified.
3. 0–4 mA square wave total control current.



**Typical Performance Data**

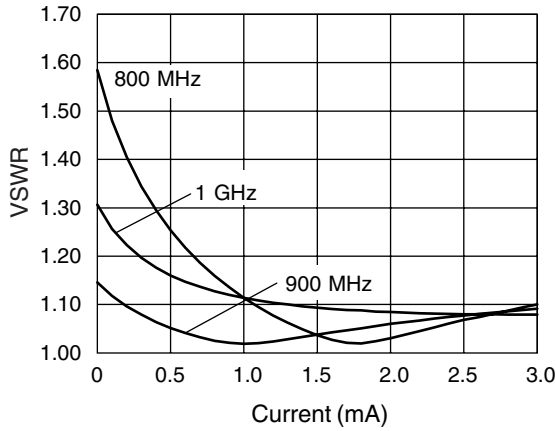

**Input/Output VSWR vs. Current**

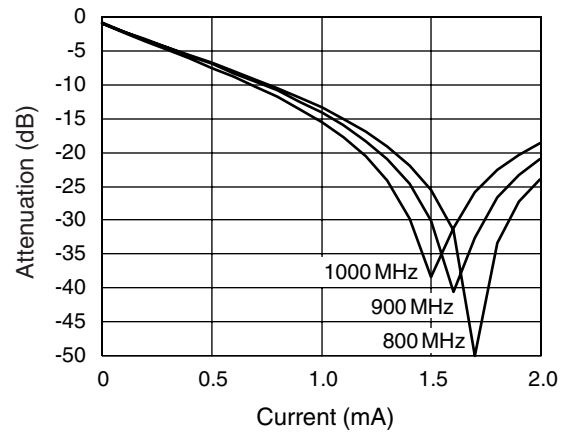

**Attenuation vs. Current**

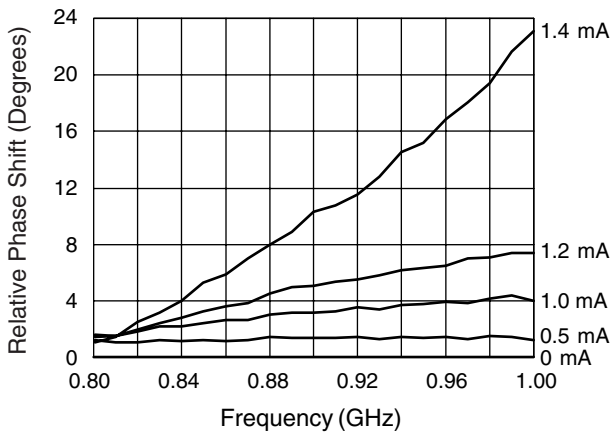

**Relative Phase vs. Frequency**

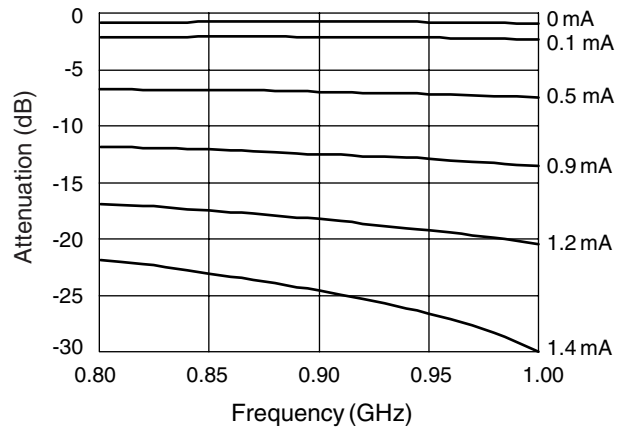

**Attenuation vs. Frequency**

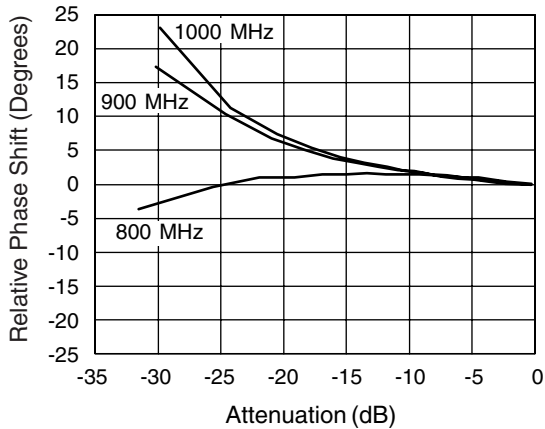

**Relative Phase vs. Attenuation**

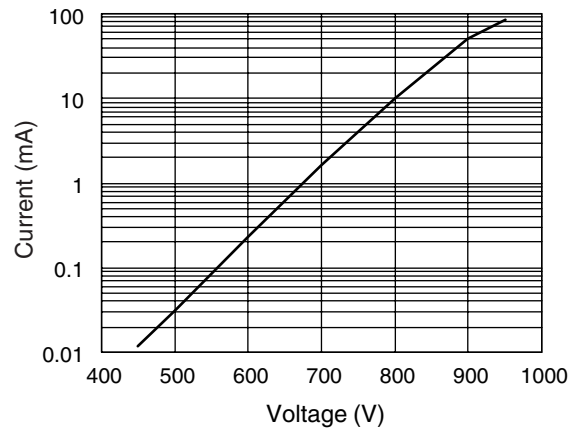

**Typical PIN Diode Current vs. Voltage**

**Pin Out**

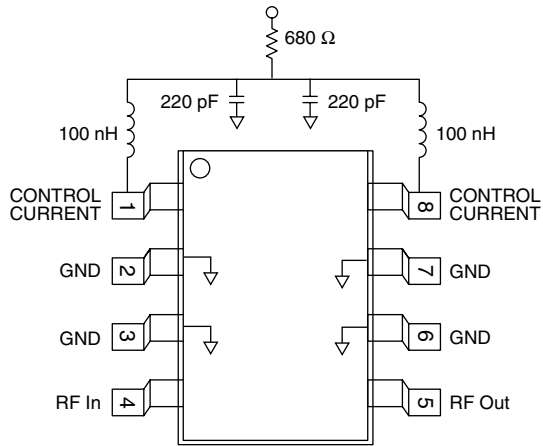

**Connection Diagram**

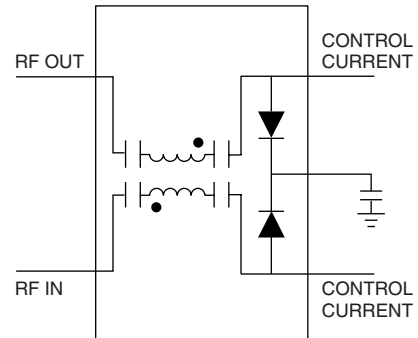

**Absolute Maximum Ratings**

Characteristic	Value
RF Input Power	0.5 W CW, 4 W @ 12.5% Duty Cycle
Control Current	50 mA per Diode
Operating Temperature	-65 to +125°C
Storage Temperature	-65 to +125°C
Maximum Reverse Diode Voltage	-100 V
Electrostatic Discharge	+125 V

Note: Operating this device above any of these parameters may cause irreversible damage.

**SOIC-8**

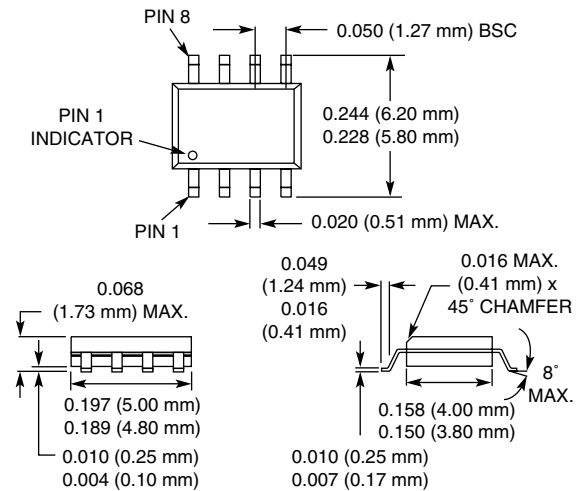

**Recommended Board Layout**

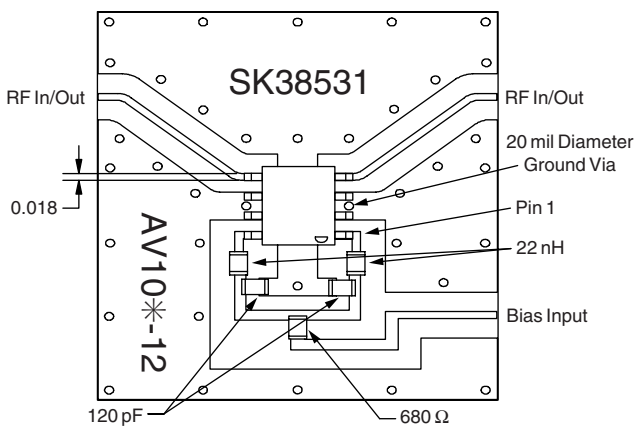

Material is 10 mil FR4.