

DATA SHEET

74ALVT16374

2.5V/3.3V 16-bit edge-triggered
D-type flip-flop (3-State)

Product specification
Supersedes data of 1998 Feb 13
IC23 Data Handbook

1999 Oct 18



2.5V/3.3V 16-bit edge-triggered D-type flip-flop (3-State)

74ALVT16374

FEATURES

- 16-bit edge-triggered flip-flop
- 5V I/O compatible
- 3-State buffers
- Output capability: +64mA/-32mA
- TTL input and output switching levels
- Input and output interface capability to systems at 5V supply
- Bus-hold data inputs eliminate the need for external pull-up resistors to hold unused inputs
- Live insertion/extraction permitted
- Power-up reset
- Power-up 3-State
- No bus current loading when output is tied to 5V bus
- Latch-up protection exceeds 500mA per JEDEC Std 17
- ESD protection exceeds 2000V per MIL STD 883 Method 3015 and 200V per Machine Model

DESCRIPTION

The 74ALVT16374 is a high-performance BiCMOS product designed for V_{CC} operation at 2.5V or 3.3V with I/O compatibility up to 5V.

This device is a 16-bit edge-triggered D-type flip-flop featuring non-inverting 3-State outputs. The device can be used as two 8-bit flip-flops or one 16-bit flip-flop. On the positive transition of the clock (CP), the Q outputs of the flip-flop take on the logic levels set up at the D inputs.

QUICK REFERENCE DATA

SYMBOL	PARAMETER	CONDITIONS $T_{amb} = 25^{\circ}\text{C}$	TYPICAL		UNIT
			2.5V	3.3V	
t_{PLH} t_{PHL}	Propagation delay nCP to nQx	$C_L = 50\text{pF}$	2.6 2.8	2.1 2.3	ns
C_{IN}	Input capacitance DIR, \overline{OE}	$V_I = 0\text{V}$ or V_{CC}	3	3	pF
C_{Out}	Output capacitance	Outputs disabled; $V_O = 0\text{V}$ or V_{CC}	9	9	pF
I_{CCZ}	Total supply current	Outputs disabled	40	40	μA

ORDERING INFORMATION

PACKAGES	TEMPERATURE RANGE	OUTSIDE NORTH AMERICA	NORTH AMERICA	DWG NUMBER
48-Pin Plastic SSOP Type III	-40°C to $+85^{\circ}\text{C}$	74ALVT16374 DL	AV16374 DL	SOT370-1
48-Pin Plastic TSSOP Type II	-40°C to $+85^{\circ}\text{C}$	74ALVT16374 DGG	AV16374 DGG	SOT362-1

2.5V/3.3V 16-bit edge-triggered D-type flip-flop (3-State)

74ALVT16374

LOGIC SYMBOL

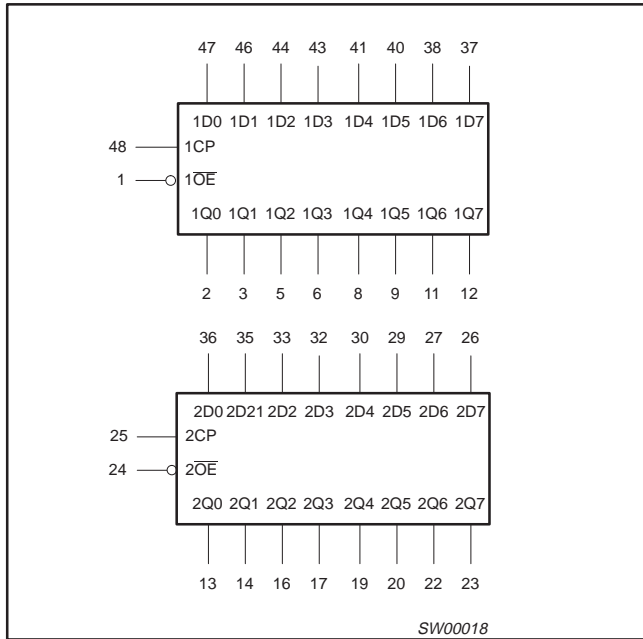

PIN CONFIGURATION

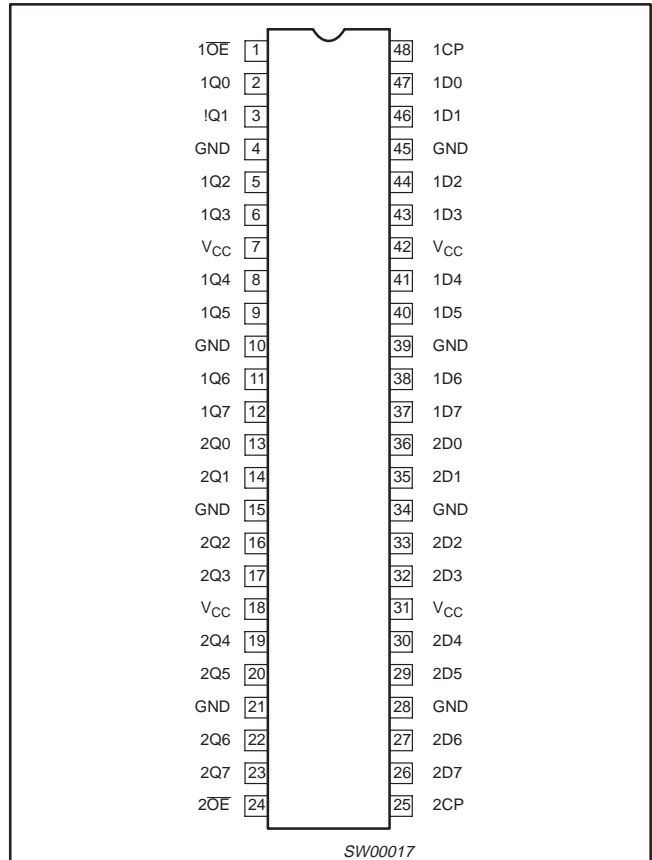

LOGIC SYMBOL (IEEE/IEC)

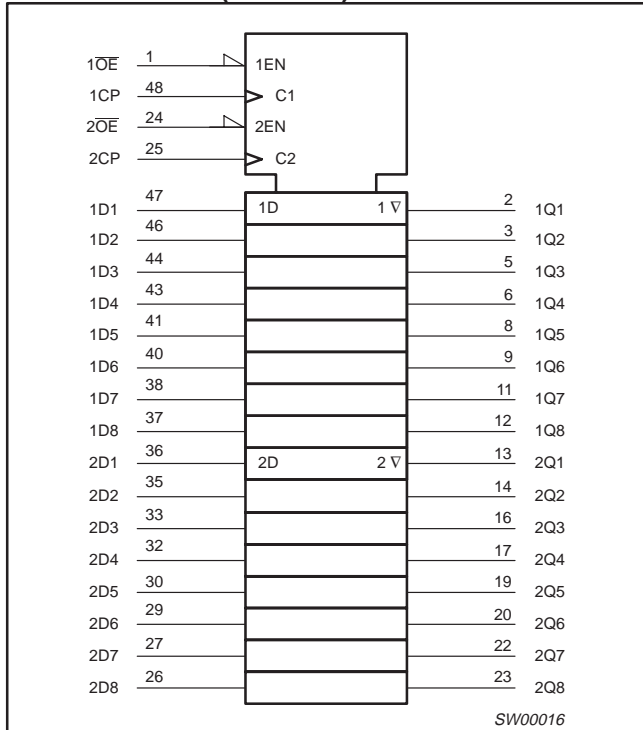

PIN DESCRIPTION

PIN NUMBER	SYMBOL	FUNCTION
47, 46, 44, 43, 41, 40, 38, 37, 36, 35, 33, 32, 30, 29, 27, 26	1D0 - 1D7 2D0 - 2D7	Data inputs
2, 3, 5, 6, 8, 9, 11, 12, 13, 14, 16, 17, 19, 20, 22, 23	1Q0 - 1Q7 2Q0 - 2Q7	Data outputs
1, 24	1OE, 2OE	Output enable inputs (active-Low)
48, 25	1CP, 2CP	Clock pulse inputs (active rising edge)
4, 10, 15, 21, 28, 34, 39, 45	GND	Ground (0V)
7, 18, 31, 42	VCC	Positive supply voltage

2.5V/3.3V 16-bit edge-triggered D-type flip-flop (3-State)

74ALVT16374

FUNCTION TABLE

INPUTS			INTERNAL REGISTER	OUTPUTS	OPERATING MODE
nOE	nCP	nDx		nQ0 - nQ7	
L L	↑ ↑	l h	L H	L H	Load and read register
L	↕	X	NC	NC	Hold
H H	↕ ↑	X nDx	NC nDx	Z Z	Disable outputs

- H = High voltage level
- h = High voltage level one set-up time prior to the High-to-Low E transition
- L = Low voltage level
- l = Low voltage level one set-up time prior to the High-to-Low E transition
- NC = No change
- X = Don't care
- Z = High impedance "off" state
- ↑ = Low-to-High clock transition
- ↕ = Not a Low-to-High clock transition

LOGIC DIAGRAM

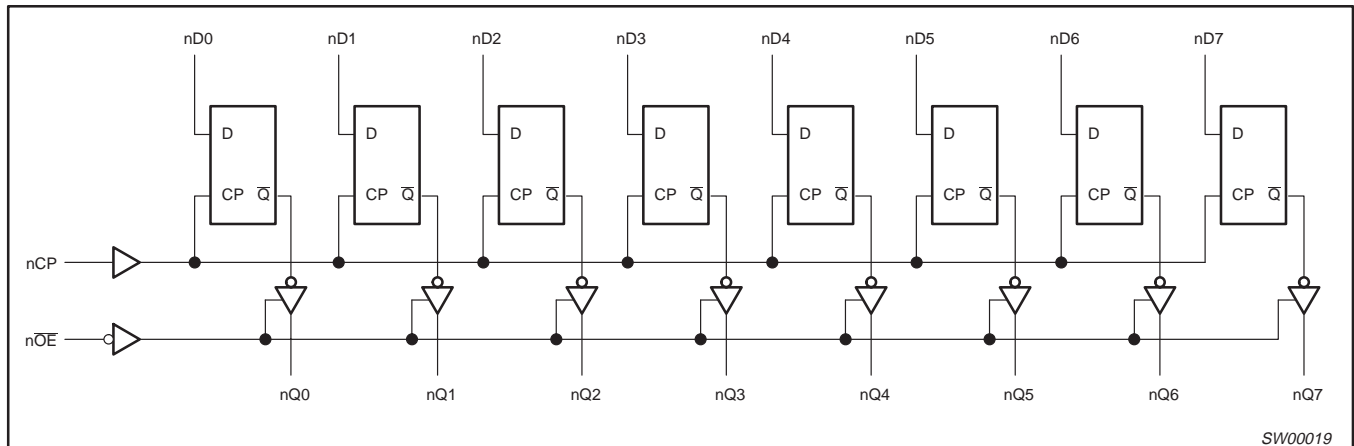

2.5V/3.3V 16-bit edge-triggered D-type flip-flop (3-State)

74ALVT16374

ABSOLUTE MAXIMUM RATINGS^{1,2}

SYMBOL	PARAMETER	CONDITIONS	RATING	UNIT
V _{CC}	DC supply voltage		-0.5 to +4.6	V
I _{IK}	DC input diode current	V _I < 0	-50	mA
V _I	DC input voltage ³		-0.5 to +7.0	V
I _{OK}	DC output diode current	V _O < 0	-50	mA
V _{OUT}	DC output voltage ³	Output in Off or High state	-0.5 to +7.0	V
I _{OUT}	DC output current	Output in Low state	128	mA
		Output in High state	-64	
T _{stg}	Storage temperature range		-65 to +150	°C

NOTES:

- Stresses beyond those listed may cause permanent damage to the device. These are stress ratings only and functional operation of the device at these or any other conditions beyond those indicated under "recommended operating conditions" is not implied. Exposure to absolute-maximum-rated conditions for extended periods may affect device reliability.
- The performance capability of a high-performance integrated circuit in conjunction with its thermal environment can create junction temperatures which are detrimental to reliability. The maximum junction temperature of this integrated circuit should not exceed 150°C.
- The input and output negative voltage ratings may be exceeded if the input and output clamp current ratings are observed.

RECOMMENDED OPERATING CONDITIONS

SYMBOL	PARAMETER	2.5V RANGE LIMITS		3.3V RANGE LIMITS		UNIT
		MIN	MAX	MIN	MAX	
V _{CC}	DC supply voltage	2.3	2.7	3.0	3.6	V
V _I	Input voltage	0	5.5	0	5.5	V
V _{IH}	High-level input voltage	1.7		2.0		V
V _{IL}	Input voltage		0.7		0.8	V
I _{OH}	High-level output current		-8		-32	mA
I _{OL}	Low-level output current		8		32	mA
	Low-level output current; current duty cycle ≤ 50%; f ≥ 1kHz		24		64	
Δt/Δv	Input transition rise or fall rate; Outputs enabled		10		10	ns/V
T _{amb}	Operating free-air temperature range	-40	+85	-40	+85	°C

2.5V/3.3V 16-bit edge-triggered D-type flip-flop (3-State)

74ALVT16374

DC ELECTRICAL CHARACTERISTICS (3.3V ± 0.3V RANGE)

SYMBOL	PARAMETER	TEST CONDITIONS	LIMITS			UNIT
			Temp = -40°C to +85°C			
			MIN	TYP ¹	MAX	
V _{IK}	Input clamp voltage	V _{CC} = 3.0V; I _{IK} = -18mA		-0.85	-1.2	V
V _{OH}	High-level output voltage	V _{CC} = 3.0 to 3.6V; I _{OH} = -100µA	V _{CC} -0.2	V _{CC}		V
		V _{CC} = 3.0V; I _{OH} = -32mA	2.0	2.3		
V _{OL}	Low-level output voltage	V _{CC} = 3.0V; I _{OL} = 100µA		0.07	0.2	V
		V _{CC} = 3.0V; I _{OL} = 16mA		0.25	0.4	
		V _{CC} = 3.0V; I _{OL} = 32mA		0.3	0.5	
		V _{CC} = 3.0V; I _{OL} = 64mA		0.4	0.55	
V _{RST}	Power-up output low voltage ⁶	V _{CC} = 3.6V; I _O = 1mA; V _I = V _{CC} or GND			0.55	V
I _I	Input leakage current	V _{CC} = 3.6V; V _I = V _{CC} or GND	Control pins	0.1	±1	µA
		V _{CC} = 0 or 3.6V; V _I = 5.5V		0.1	10	
		V _{CC} = 3.6V; V _I = V _{CC}	Data pins ⁴	0.1	1	
		V _{CC} = 3.6V; V _I = 0V		0.1	-5	
I _{OFF}	Off current	V _{CC} = 0V; V _I or V _O = 0 to 4.5V		0.1	±100	µA
I _{HOLD}	Bus Hold current Data inputs ⁷	V _{CC} = 3V; V _I = 0.8V	75	130		µA
		V _{CC} = 3V; V _I = 2.0V	-75	-140		
		V _{CC} = 0V to 3.6V; V _{CC} = 3.6V	±500			
I _{EX}	Current into an output in the High state when V _O > V _{CC}	V _O = 5.5V; V _{CC} = 3.0V		10	125	µA
I _{PU/PD}	Power up/down 3-State output current ³	V _{CC} ≤ 1.2V; V _O = 0.5V to V _{CC} ; V _I = GND or V _{CC} OE/OE = Don't care		1	±100	µA
I _{OZH}	3-State output High current	V _{CC} = 3.6V; V _O = 3.0V; V _I = V _{IL} or V _{IH}		0.5	5	µA
I _{OZL}	3-State output Low current	V _{CC} = 3.6V; V _O = 0.5V; V _I = V _{IL} or V _{IH}		0.5	-5	µA
I _{CCH}	Quiescent supply current	V _{CC} = 3.6V; Outputs High, V _I = GND or V _{CC} , I _O = 0		0.04	0.1	mA
I _{CCL}		V _{CC} = 3.6V; Outputs Low, V _I = GND or V _{CC} , I _O = 0		3.7	6	
I _{CCZ}		V _{CC} = 3.6V; Outputs Disabled; V _I = GND or V _{CC} , I _O = 0 ⁵		0.04	0.1	
ΔI _{CC}	Additional supply current per input pin ²	V _{CC} = 3V to 3.6V; One input at V _{CC} -0.6V, Other inputs at V _{CC} or GND		0.04	0.4	mA

NOTES:

- All typical values are at V_{CC} = 3.3V and T_{amb} = 25°C.
- This is the increase in supply current for each input at the specified voltage level other than V_{CC} or GND
- This parameter is valid for any V_{CC} between 0V and 1.2V with a transition time of up to 10msec. From V_{CC} = 1.2V to V_{CC} = 3.3V ± 0.3V a transition time of 100µsec is permitted. This parameter is valid for T_{amb} = 25°C only.
- Unused pins at V_{CC} or GND.
- I_{CCZ} is measured with outputs pulled up to V_{CC} or pulled down to ground.
- For valid test results, data must not be loaded into the flip-flops (or latches) after applying power.
- This is the bus hold overdrive current required to force the input to the opposite logic state.

AC CHARACTERISTICS (3.3V ± 0.3V RANGE)

GND = 0V; t_R = t_F = 2.5ns; C_L = 50pF; R_L = 500Ω; T_{amb} = -40°C to +85°C.

SYMBOL	PARAMETER	WAVEFORM	LIMITS			UNIT
			V _{CC} = 3.3V ± 0.3V			
			MIN	TYP ¹	MAX	
f _{max}	Maximum clock frequency	1	250			MHz
t _{PLH} t _{PHL}	Propagation delay nCp to nQx	1	1.0 1.0	2.1 2.3	3.2 3.2	ns
t _{PZH} t _{PZL}	Output enable time to High and Low level	3 4	1.0 1.0	2.3 2.0	3.8 3.2	ns
t _{PHZ} t _{PLZ}	Output disable time from High and Low Level	3 4	1.0 1.0	2.7 2.3	4.2 3.4	ns

NOTE:

- All typical values are at V_{CC} = 3.3V and T_{amb} = 25°C.

2.5V/3.3V 16-bit edge-triggered D-type flip-flop (3-State)

74ALVT16374

DC ELECTRICAL CHARACTERISTICS (2.5V ± 0.2V RANGE)

SYMBOL	PARAMETER	TEST CONDITIONS	LIMITS			UNIT
			Temp = -40°C to +85°C			
			MIN	TYP ¹	MAX	
V _{IK}	Input clamp voltage	V _{CC} = 2.3V; I _{IK} = -18mA		-0.85	-1.2	V
V _{OH}	High-level output voltage	V _{CC} = 2.3 to 3.6V; I _{OH} = -100μA	V _{CC} -0.2	V _{CC}		V
		V _{CC} = 2.3V; I _{OH} = -8mA	1.8	2.1		
V _{OL}	Low-level output voltage	V _{CC} = 2.3V; I _{OL} = 100μA		0.07	0.2	
		V _{CC} = 2.3V; I _{OL} = 24mA		0.3	0.5	
V _{RST}	Power-up output low voltage ⁷	V _{CC} = 2.7V; I _O = 1mA; V _I = V _{CC} or GND			0.55	V
I _I	Input leakage current	V _{CC} = 2.7V; V _I = V _{CC} or GND	Control pins	0.1	±1	μA
		V _{CC} = 0 or 2.7V; V _I = 5.5V		0.1	10	
		V _{CC} = 2.7V; V _I = V _{CC}	Data pins ⁴	0.1	1	
		V _{CC} = 2.7V; V _I = 0		0.1	-5	
I _{OFF}	Off current	V _{CC} = 0V; V _I or V _O = 0 to 4.5V		0.1	±100	μA
I _{HOLD}	Bus Hold current Data inputs ⁶	V _{CC} = 2.3V; V _I = 0.7V		90		μA
		V _{CC} = 2.3V; V _I = 1.7V		-10		
I _{EX}	Current into an output in the High state when V _O > V _{CC}	V _O = 5.5V; V _{CC} = 2.3V		10	125	μA
I _{PU/PD}	Power up/down 3-State output current ³	V _{CC} ≤ 1.2V; V _O = 0.5V to V _{CC} ; V _I = GND or V _{CC} ; OE/OE = Don't care		1	100	μA
I _{OZH}	3-State output High current	V _{CC} = 2.7V; V _O = 2.3V; V _I = V _{IL} or V _{IH}		0.5	5	μA
I _{OZL}	3-State output Low current	V _{CC} = 2.7V; V _O = 0.5V; V _I = V _{IL} or V _{IH}		0.5	-5	μA
I _{CCH}	Quiescent supply current	V _{CC} = 2.7V; Outputs High, V _I = GND or V _{CC} , I _O = 0		0.04	0.1	mA
I _{CCL}		V _{CC} = 2.7V; Outputs Low, V _I = GND or V _{CC} , I _O = 0		2.7	4.5	
I _{CCZ}		V _{CC} = 2.7V; Outputs Disabled; V _I = GND or V _{CC} , I _O = 0 ⁵		0.04	0.1	
ΔI _{CC}	Additional supply current per input pin ²	V _{CC} = 2.3V to 2.7V; One input at V _{CC} -0.6V, Other inputs at V _{CC} or GND		0.04	0.4	mA

NOTES:

- All typical values are at V_{CC} = 2.5V and T_{amb} = 25°C.
- This is the increase in supply current for each input at the specified voltage level other than V_{CC} or GND.
- This parameter is valid for any V_{CC} between 0V and 1.2V with a transition time of up to 10msec. From V_{CC} = 1.2V to V_{CC} = 2.5V ± 0.3V a transition time of 100μsec is permitted. This parameter is valid for T_{amb} = 25°C only.
- Unused pins at V_{CC} or GND.
- I_{CCZ} is measured with outputs pulled up to V_{CC} or pulled down to ground.
- Not guaranteed.
- For valid test results, data must not be loaded into the flip-flops (or latches) after applying power.

AC CHARACTERISTICS (2.5V ± 0.2V RANGE)

GND = 0V; t_R = t_F = 2.5ns; C_L = 50pF; R_L = 500Ω; T_{amb} = -40°C to +85°C.

SYMBOL	PARAMETER	WAVEFORM	LIMITS			UNIT
			V _{CC} = 2.5V ± 0.2V			
			MIN	TYP ¹	MAX	
f _{max}	Maximum clock frequency	1	150			MHz
t _{PLH} t _{PHL}	Propagation delay nCp to nQx	1	1.5	2.6	4.2	ns
			1.5	2.8	4.5	
t _{PZH} t _{PZL}	Output enable time to High and Low level	3	1.0	3.4	5.6	ns
		4	1.0	2.6	4.7	
t _{PHZ} t _{PLZ}	Output disable time from High and Low Level	3	2.0	2.7	4.4	ns
		4	1.0	2.0	3.3	

NOTE:

- All typical values are at V_{CC} = 2.5V and T_{amb} = 25°C.

2.5V/3.3V 16-bit edge-triggered D-type flip-flop (3-State)

74ALVT16374

AC SETUP REQUIREMENTS

GND = 0V; $t_R = t_F = 2.5\text{ns}$; $C_L = 50\text{pF}$; $R_L = 500\Omega$; $T_{\text{amb}} = -40^\circ\text{C}$ to $+85^\circ\text{C}$.

SYMBOL	PARAMETER	WAVEFORM	LIMITS		LIMITS		UNIT
			$V_{CC} = 2.5V \pm 0.2V$		$V_{CC} = 3.3V \pm 0.3V$		
			MIN	TYP	MIN	TYP	
$t_{S(H)}$ $t_{S(L)}$	Setup time nDx to nCP	2	1.0 1.5	0 0.4	1.0 1.5	0 0	ns
$t_{H(H)}$ $t_{H(L)}$	Hold time nDx to nCP	2	0.5 0.5	0 0	0.5 0.5	0 0	ns
$t_{W(H)}$ $t_{W(L)}$	nCP pulse width High or Low	1	1.5 1.5		1.5 1.5		ns

AC WAVEFORMS

$V_M = 1.5V$ for $V_{CC} \geq 3.0V$; $V_M = V_{CC}/2$ for $V_{CC} \leq 2.7V$
 $V_X = V_{OL} + 0.3V$ for $V_{CC} \geq 3.0V$; $V_X = V_{OL} + 0.15V$ for $V_{CC} \leq 2.7V$
 $V_Y = V_{OH} - 0.3V$ for $V_{CC} \geq 3.0V$; $V_Y = V_{OH} - 0.15V$ for $V_{CC} \leq 2.7V$

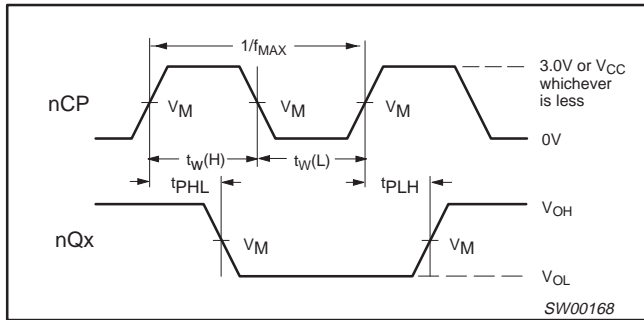

Waveform 1. Propagation Delay, Clock Input to Output, Clock Pulse Width, and Maximum Clock Frequency

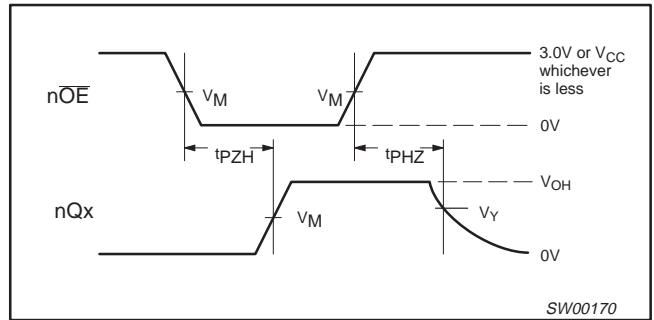

Waveform 3. 3-State Output Enable Time to High Level and Output Disable Time from High Level

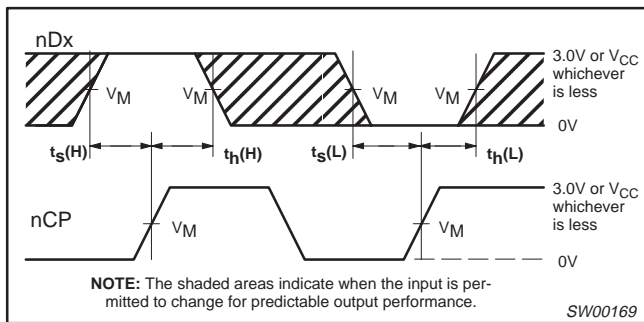

Waveform 2. Data Setup and Hold Times

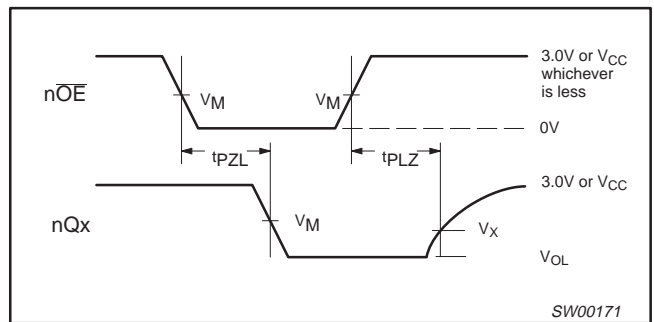

Waveform 4. 3-State Output Enable Time to Low Level and Output Disable Time from Low Level

2.5V/3.3V 16-bit edge-triggered D-type flip-flop (3-State)

74ALVT16374

TEST CIRCUIT AND WAVEFORMS

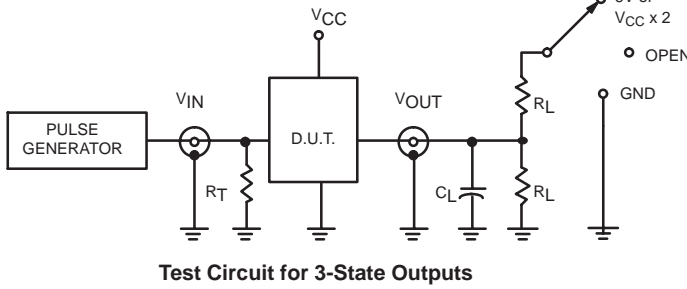

Test Circuit for 3-State Outputs

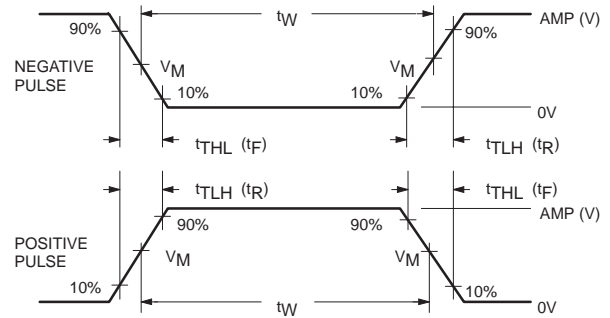

$V_M = 1.5V$ or $V_{CC} / 2$, whichever is less
Input Pulse Definition

SWITCH POSITION

TEST	SWITCH
t_{PHZ}/t_{PZH}	GND
t_{PLZ}/t_{PZL}	6V or $V_{CC} \times 2$
t_{PLH}/t_{PHL}	open

DEFINITIONS

R_L = Load resistor; see AC CHARACTERISTICS for value.

C_L = Load capacitance includes jig and probe capacitance; see AC CHARACTERISTICS for value.

R_T = Termination resistance should be equal to Z_{OUT} of pulse generators.

FAMILY	INPUT PULSE REQUIREMENTS				
	Amplitude	Rep. Rate	t_W	t_R	t_F
74ALVT16	3.0V or V_{CC} whichever is less	$\leq 10\text{MHz}$	500ns	$\leq 2.5\text{ns}$	$\leq 2.5\text{ns}$

2.5V/3.3V ALVT 16-bit edge-triggered D-type flip-flop
(3-State)

74ALVT16374

SSOP48: plastic shrink small outline package; 48 leads; body width 7.5 mm

SOT370-1

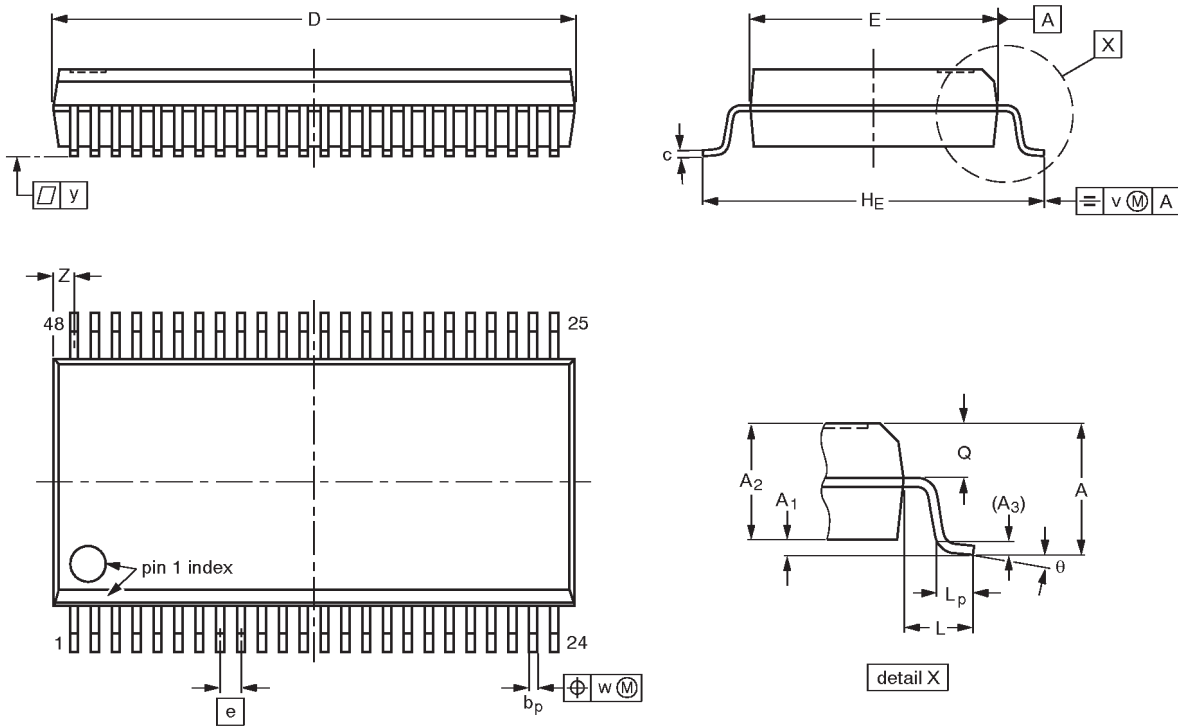

DIMENSIONS (mm are the original dimensions)

UNIT	A max.	A ₁	A ₂	A ₃	b _p	c	D ⁽¹⁾	E ⁽¹⁾	e	H _E	L	L _p	Q	v	w	y	Z ⁽¹⁾	θ
mm	2.8	0.4 0.2	2.35 2.20	0.25	0.3 0.2	0.22 0.13	16.00 15.75	7.6 7.4	0.635	10.4 10.1	1.4	1.0 0.6	1.2 1.0	0.25	0.18	0.1	0.85 0.40	8° 0°

Note

1. Plastic or metal protrusions of 0.25 mm maximum per side are not included.

OUTLINE VERSION	REFERENCES				EUROPEAN PROJECTION	ISSUE DATE
	IEC	JEDEC	EIAJ			
SOT370-1		MO-118AA				93-11-02 95-02-04

2.5V/3.3V ALVT 16-bit edge-triggered D-type flip-flop
(3-State)

74ALVT16374

TSSOP48: plastic thin shrink small outline package; 48 leads; body width 6.1mm

SOT362-1

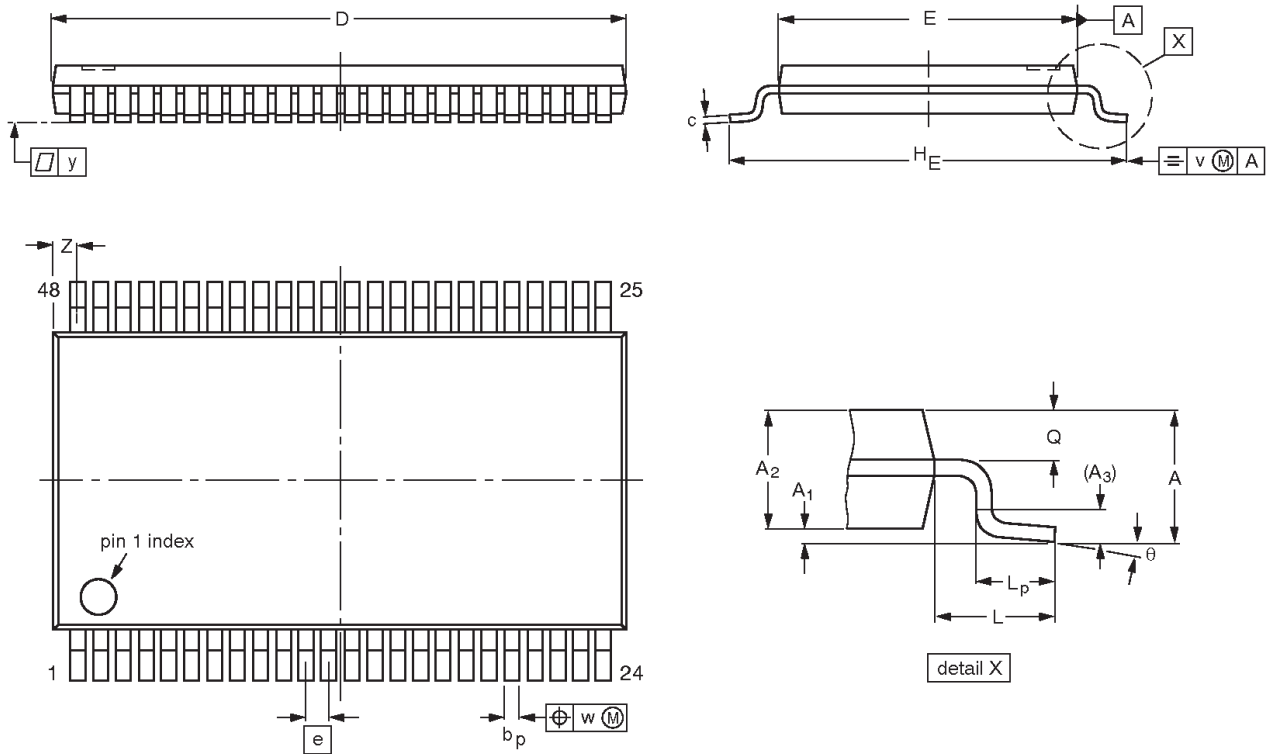

DIMENSIONS (mm are the original dimensions).

UNIT	A max.	A ₁	A ₂	A ₃	b _p	c	D ⁽¹⁾	E ⁽²⁾	e	H _E	L	L _p	Q	v	w	y	Z	θ
mm	1.2	0.15 0.05	1.05 0.85	0.25	0.28 0.17	0.2 0.1	12.6 12.4	6.2 6.0	0.5	8.3 7.9	1	0.8 0.4	0.50 0.35	0.25	0.08	0.1	0.8 0.4	8° 0°

Notes

1. Plastic or metal protrusions of 0.15 mm maximum per side are not included.
2. Plastic interlead protrusions of 0.25 mm maximum per side are not included.

OUTLINE VERSION	REFERENCES				EUROPEAN PROJECTION	ISSUE DATE
	IEC	JEDEC	EIAJ			
SOT362-1		MO-153ED				93-02-03 95-02-10

2.5V/3.3V ALVT 16-bit edge-triggered D-type flip-flop (3-State)

74ALVT16374

Data sheet status

Data sheet status	Product status	Definition [1]
Objective specification	Development	This data sheet contains the design target or goal specifications for product development. Specification may change in any manner without notice.
Preliminary specification	Qualification	This data sheet contains preliminary data, and supplementary data will be published at a later date. Philips Semiconductors reserves the right to make changes at any time without notice in order to improve design and supply the best possible product.
Product specification	Production	This data sheet contains final specifications. Philips Semiconductors reserves the right to make changes at any time without notice in order to improve design and supply the best possible product.

[1] Please consult the most recently issued datasheet before initiating or completing a design.

Definitions

Short-form specification — The data in a short-form specification is extracted from a full data sheet with the same type number and title. For detailed information see the relevant data sheet or data handbook.

Limiting values definition — Limiting values given are in accordance with the Absolute Maximum Rating System (IEC 134). Stress above one or more of the limiting values may cause permanent damage to the device. These are stress ratings only and operation of the device at these or at any other conditions above those given in the Characteristics sections of the specification is not implied. Exposure to limiting values for extended periods may affect device reliability.

Application information — Applications that are described herein for any of these products are for illustrative purposes only. Philips Semiconductors make no representation or warranty that such applications will be suitable for the specified use without further testing or modification.

Disclaimers

Life support — These products are not designed for use in life support appliances, devices or systems where malfunction of these products can reasonably be expected to result in personal injury. Philips Semiconductors customers using or selling these products for use in such applications do so at their own risk and agree to fully indemnify Philips Semiconductors for any damages resulting from such application.

Right to make changes — Philips Semiconductors reserves the right to make changes, without notice, in the products, including circuits, standard cells, and/or software, described or contained herein in order to improve design and/or performance. Philips Semiconductors assumes no responsibility or liability for the use of any of these products, conveys no license or title under any patent, copyright, or mask work right to these products, and makes no representations or warranties that these products are free from patent, copyright, or mask work right infringement, unless otherwise specified.

Philips Semiconductors
811 East Arques Avenue
P.O. Box 3409
Sunnyvale, California 94088-3409
Telephone 800-234-7381

© Copyright Philips Electronics North America Corporation 1999
All rights reserved. Printed in U.S.A.

print code

Date of release: 10-99

Document order number:

9397-750-06513

Let's make things better.