

DATA SHEET

74ALVT16952

2.5V/3.3V ALVT 16-bit registered
transceiver (3-State)

Product specification
Supersedes data of 1995 Sep 19
IC23 Data Handbook

1998 Mar 19

2.5V/3.3V 16-bit registered transceiver (3-State)

74ALVT16952

FEATURES

- Two 8-bit registered transceivers
- 5V I/O Compatible
- 3-State buffers
- Output capability: +64mA/-32mA
- TTL input and output switching levels
- Input and output interface capability to systems at 5V supply
- Bus hold data inputs eliminate the need for external pull-up resistors to hold unused inputs
- Live insertion/extraction permitted
- Power-up 3-State
- Power-up reset
- No bus current loading when output is tied to 5V bus
- Latch-up protection exceeds 500mA per JEDEC Std 17
- ESD protection exceeds 2000V per MIL STD 883 Method 3015 and 200V per Machine Model

DESCRIPTION

The 74ALVT16952 is a high-performance BiCMOS product designed for V_{CC} operation at 2.5V or 3.3V with I/O compatibility up to 5V.

The 74ALVT16952 is a dual octal registered transceiver. Two 8-bit registers store data flowing in both directions between two bidirectional buses. Data applied to the inputs is entered and stored on the rising edge of the Clock ($nCPXX$) provided that the Clock Enable ($nCEXX$) is Low. The data is then present at the 3-State output buffers, but is only accessible when the Output Enable ($nOEXX$) is Low. Data flow from A inputs to B outputs is the same as for B inputs to A outputs.

Active bus hold circuitry is provided to hold unused or floating data inputs at a valid logic level.

QUICK REFERENCE DATA

SYMBOL	PARAMETER	CONDITIONS $T_{amb} = 25^{\circ}C; GND = 0V$	TYPICAL		UNIT
			2.5V	3.3V	
t_{PLH} t_{PHL}	Propagation delay nCPBA to nAx or nCPAB to nBx	$C_L = 50pF;$	3.0 3.0	2.3 2.3	ns
C_{IN}	Input capacitance	$V_I = 0V$ or V_{CC}	3	3	pF
$C_{I/O}$	I/O pin capacitance	$V_{I/O} = 0V$ or V_{CC} Outputs disabled	9	9	pF
I_{CCZ}	Total supply current	Outputs disabled	40	70	μA

ORDERING INFORMATION

PACKAGES	TEMPERATURE RANGE	OUTSIDE NORTH AMERICA	NORTH AMERICA	DWG NUMBER
56-Pin Plastic SSOP Type III	-40°C to +85°C	74ALVT16952 DL	AV16952 DL	SOT371-1
56-Pin Plastic TSSOP Type II	-40°C to +85°C	74ALVT16952 DGG	AV16952 DGG	SOT364-1

LOGIC SYMBOL (IEEE/IEC)

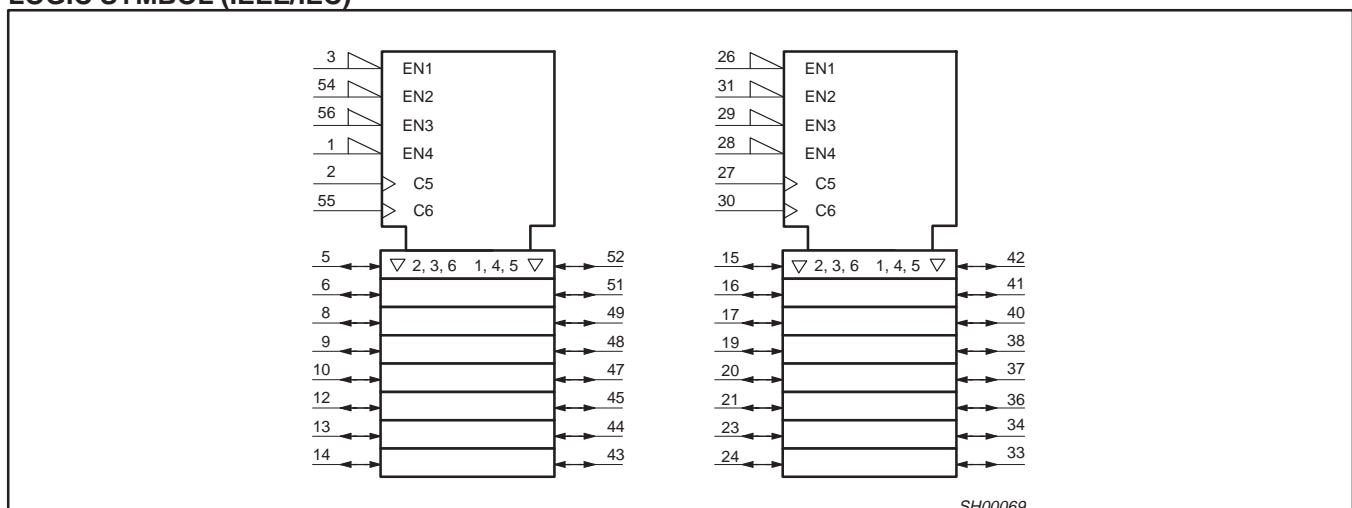

2.5V/3.3V 16-bit registered transceiver (3-State)

74ALVT16952

PIN CONFIGURATION

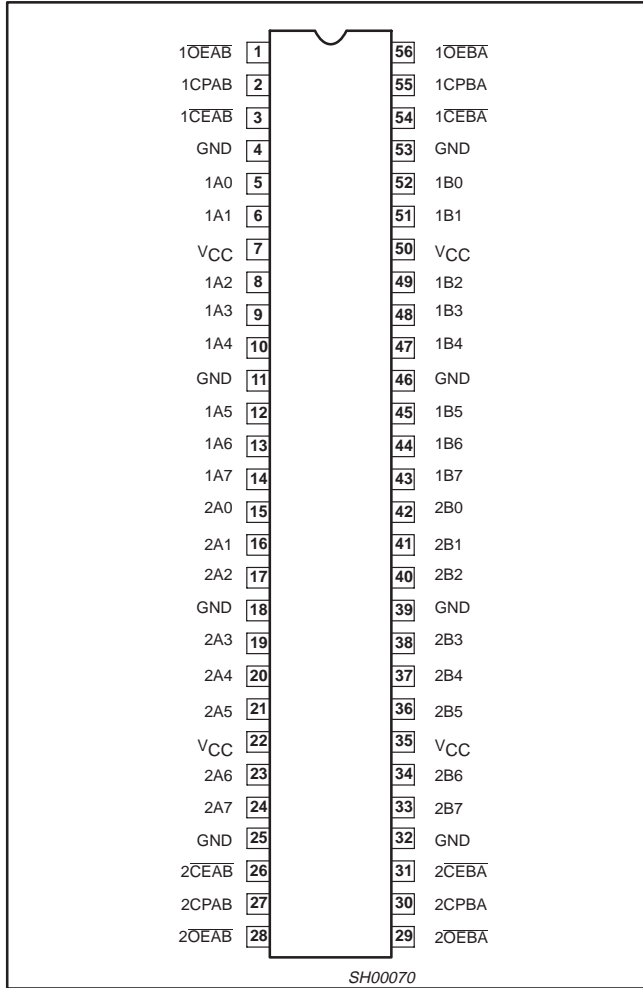

LOGIC SYMBOL

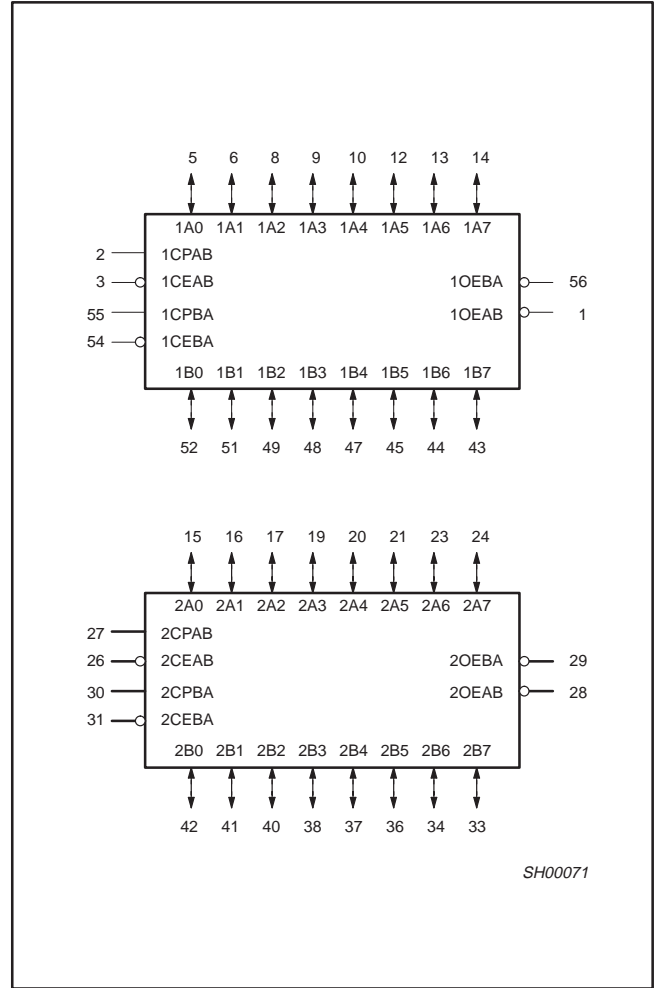

PIN DESCRIPTION

PIN NUMBER	SYMBOL	NAME AND FUNCTION
2, 55 27, 30	1CPAB / 1CPBA 2CPAB / 2CPBA	Clock input A to B / Clock input B to A
3, 54, 26, 31	1CEAB / 1CEBA 2CEAB / 2CEBA	Clock enable input A to B / Clock enable input B to A
5, 6, 8, 9, 10, 12, 13, 14, 15, 16, 17, 19, 20, 21, 23, 24	1A0 – 1A7 2A0 – 2A7	Data inputs/outputs (A side)
52, 51, 49, 48, 47, 45, 44, 43 42, 41, 40, 38, 37, 36, 34, 33	1B0 – 1B7 2B0 – 2B7	Data inputs/outputs (B side)
1, 56 28, 29	1OEAB / 1OEBA 2OEAB / 2OEBA	Output enable inputs
4, 11, 18, 25, 32, 39, 46, 53	GND	Ground (0V)
7, 22, 35, 50	V _{CC}	Positive supply voltage

2.5V/3.3V 16-bit registered transceiver (3-State)

74ALVT16952

FUNCTION TABLE for Register nAx or nBx

INPUTS			INTERNAL Q	OPERATING MODE
nAx or nBx	nCPXX	nCEXX		
X	X	H	NC	Hold data
L	↑	L	L	Load data
H	↑	L	H	

H = High voltage level
 L = Low voltage level
 ↑ = Low-to-High transition
 X = Don't care
 XX = AB or BA
 NC = No change

FUNCTION TABLE for Output Enable

INPUTS		INTERNAL Q	nAx or nBx OUTPUTS	OPERATING MODE
nOEXX	nOEXX			
H	X	X	Z	Disable outputs
L	L	L	L	Enable outputs
L	H	H	H	

H = High voltage level
 L = Low voltage level
 X = Don't care
 XX = AB or BA
 Z = High impedance "off" state

LOGIC DIAGRAM

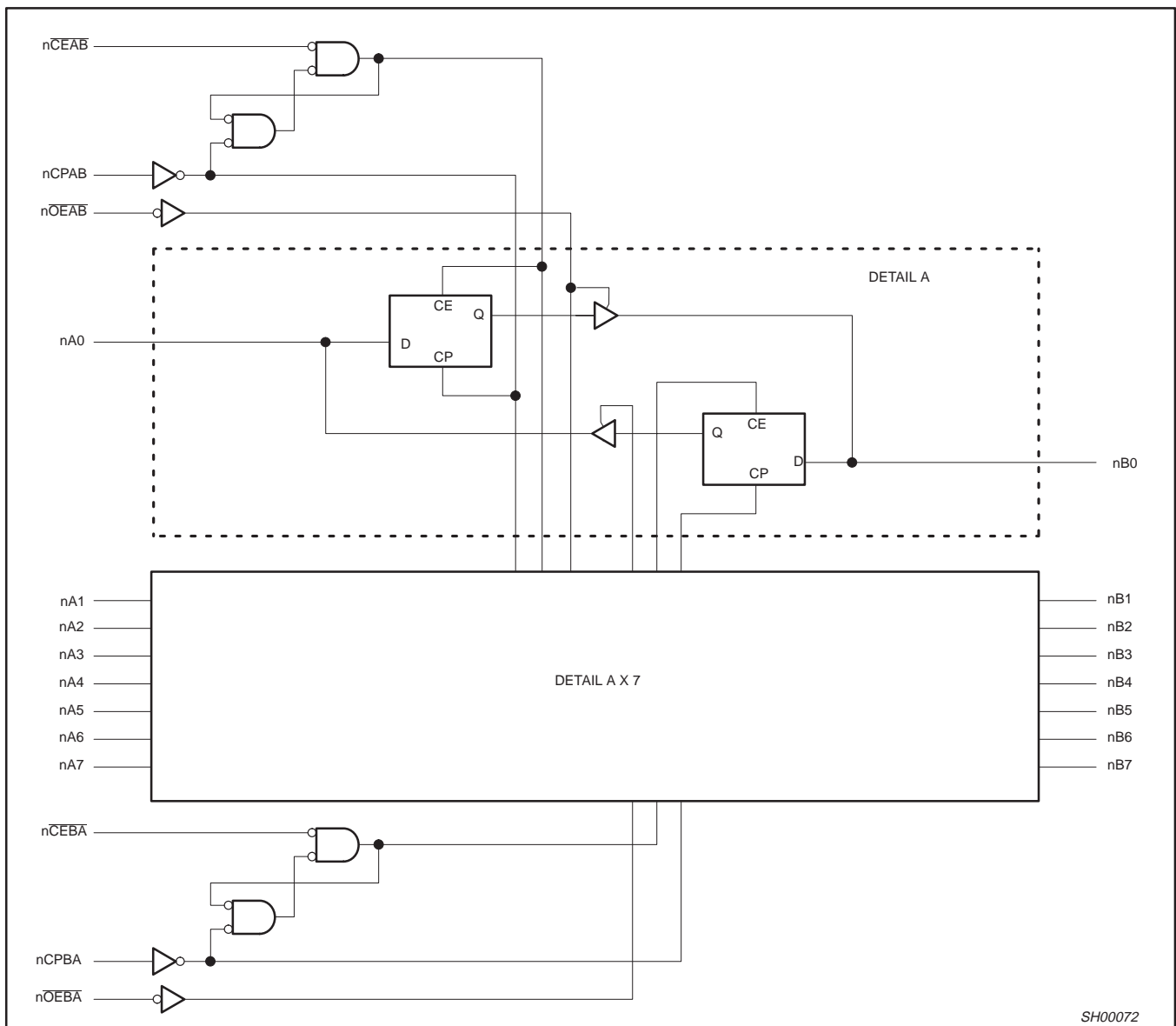

2.5V/3.3V 16-bit registered transceiver (3-State)

74ALVT16952

ABSOLUTE MAXIMUM RATINGS^{1, 2}

SYMBOL	PARAMETER	CONDITIONS	RATING	UNIT
V _{CC}	DC supply voltage		-0.5 to +4.6	V
I _{IK}	DC input diode current	V _I < 0	-50	mA
V _I	DC input voltage ³		-0.5 to +7.0	V
I _{OK}	DC output diode current	V _O < 0	-50	mA
V _{OUT}	DC output voltage ³	output in Off or High state	-0.5 to +7.0	V
I _{OUT}	DC output current	output in Low state output in High state	128 -64	mA
T _{stg}	Storage temperature range		-65 to +150	°C

NOTES:

- Stresses beyond those listed may cause permanent damage to the device. These are stress ratings only and functional operation of the device at these or any other conditions beyond those indicated under "recommended operating conditions" is not implied. Exposure to absolute-maximum-rated conditions for extended periods may affect device reliability.
- The performance capability of a high-performance integrated circuit in conjunction with its thermal environment can create junction temperatures which are detrimental to reliability. The maximum junction temperature of this integrated circuit should not exceed 150°C.
- The input and output voltage ratings may be exceeded if the input and output current ratings are observed.

RECOMMENDED OPERATING CONDITIONS

SYMBOL	PARAMETER	2.5V RANGE LIMITS		3.3V RANGE LIMITS		UNIT
		MIN	MAX	MIN	MAX	
V _{CC}	DC supply voltage	2.3	2.7	3.0	3.6	V
V _I	Input voltage	0	5.5	0	5.5	V
V _{IH}	High-level input voltage	1.7		2.0		V
V _{IL}	Input voltage		0.7		0.8	V
I _{OH}	High-level output current		-8		-32	mA
I _{OL}	Low-level output current		8		32	mA
	Low-level output current; current duty cycle ≤ 50%; f ≥ 1kHz		24		64	
Δt/Δv	Input transition rise or fall rate; Outputs enabled		10		10	ns/V
T _{amb}	Operating free-air temperature range	-40	+85	-40	+85	°C

2.5V/3.3V 16-bit registered transceiver (3-State)

74ALVT16952

DC ELECTRICAL CHARACTERISTICS (3.3V ± 0.3V RANGE)

SYMBOL	PARAMETER	TEST CONDITIONS	LIMITS			UNIT
			Temp = -40°C to +85°C			
			MIN	TYP ¹	MAX	
V _{IK}	Input clamp voltage	V _{CC} = 3.0V; I _{IK} = -18mA		-0.85	-1.2	V
V _{OH}	High-level output voltage	V _{CC} = 3.0 to 3.6V; I _{OH} = -100μA	V _{CC} -0.2	V _{CC}		V
		V _{CC} = 3.0V; I _{OH} = -32mA	2.0	2.3		
V _{OL}	Low-level output voltage	V _{CC} = 3.0V; I _{OL} = 100μA		0.07	0.2	V
		V _{CC} = 3.0V; I _{OL} = 16mA		0.25	0.4	
		V _{CC} = 3.0V; I _{OL} = 32mA		0.3	0.5	
		V _{CC} = 3.0V; I _{OL} = 64mA		0.4	0.55	
I _I	Input leakage current	V _{CC} = 3.6V; V _I = V _{CC} or GND	Control pins	0.1	±1	μA
		V _{CC} = 0 or 3.6V; V _I = 5.5V		0.1	10	
		V _{CC} = 3.6V; V _I = 5.5V	Data pins ⁴	0.1	10	
		V _{CC} = 3.6V; V _I = V _{CC}		0.1	1	
		V _{CC} = 3.6V; V _I = 0		0.1	-5	
I _{OFF}	Off current	V _{CC} = 0V; V _I or V _O = 0 to 4.5V		0.1	±100	μA
I _{HOLD}	Bus Hold current	V _{CC} = 3V; V _I = 0.8V	75	120		μA
	A or B inputs	V _{CC} = 3V; V _I = 2.0V	-75	-130		μA
I _{EX}	Current into an output in the High state when V _O > V _{CC}	V _O = 5.5V; V _{CC} = 3.0V		50	125	μA
I _{PU/PD}	Power up/down 3-State output current ³	V _{CC} ≤ 1.2V; V _O = 0.5V to V _{CC} ; V _I = GND or V _{CC} ; OE/OE̅ = Don't care		40	±100	μA
I _{CCH}	Quiescent supply current	V _{CC} = 3.6V; Outputs High, V _I = GND or V _{CC} , I _O = 0		0.07	0.1	mA
I _{CCL}		V _{CC} = 3.6V; Outputs Low, V _I = GND or V _{CC} , I _O = 0		3.5	5	
I _{CCZ}		V _{CC} = 3.6V; Outputs Disabled; V _I = GND or V _{CC} , I _O = 0 ⁵		0.07	0.1	
ΔI _{CC}	Additional supply current per input pin ²	V _{CC} = 3V to 3.6V; One input at V _{CC} -0.6V, Other inputs at V _{CC} or GND		0.04	0.4	mA

NOTES:

- All typical values are at V_{CC} = 3.3V and T_{amb} = 25°C.
- This is the increase in supply current for each input at the specified voltage level other than V_{CC} or GND.
- This parameter is valid for any V_{CC} between 0V and 1.2V with a transition time of up to 10msec. From V_{CC} = 1.2V to V_{CC} = 3.3V ± 0.3V a transition time of 100μsec is permitted. This parameter is valid for T_{amb} = 25°C only.
- Unused pins at V_{CC} or GND.
- I_{CCZ} is measured with outputs pulled up to V_{CC} or pulled down to ground.

2.5V/3.3V 16-bit registered transceiver (3-State)

74ALVT16952

AC CHARACTERISTICS (3.3V ± 0.3V RANGE)GND = 0V; $t_R = t_F = 2.5\text{ns}$; $C_L = 50\text{pF}$; $R_L = 500\Omega$; $T_{\text{amb}} = -40^\circ\text{C}$ to $+85^\circ\text{C}$

SYMBOL	PARAMETER	WAVEFORM	LIMITS			UNIT
			$V_{CC} = 3.3V \pm 0.3V$			
			MIN	TYP ¹	MAX	
f_{MAX}	Maximum clock frequency	1	100	142		MHz
t_{PLH} t_{PHL}	Propagation delay nCPBA to nAx, nCPAB to nBx	1	1.0 1.0	2.3 2.3	3.5 3.4	ns
t_{PZH} t_{PZL}	Output enable time nOEBA to nAx, nOEAB to nBx	3 4	1.0 0.5	2.4 1.8	3.8 3.0	ns
t_{PHZ} t_{PLZ}	Output disable time nOEBA to nAx, nOEAB to nBx	3 4	1.0 1.0	2.9 2.3	4.5 3.6	ns

NOTES:1. All typical values are at $V_{CC} = 3.3V$ and $T_{\text{amb}} = 25^\circ\text{C}$ **AC SETUP REQUIREMENTS (3.3V ± 0.3V RANGE)**GND = 0V; $t_R = t_F = 2.5\text{ns}$; $C_L = 50\text{pF}$; $R_L = 500\Omega$; $T_{\text{amb}} = -40^\circ\text{C}$ to $+85^\circ\text{C}$

SYMBOL	PARAMETER	WAVEFORM	LIMITS		UNIT
			$V_{CC} = 3.3V \pm 0.3V$		
			MIN	TYP	
$t_s(\text{H})$ $t_s(\text{L})$	Setup time nAx to nCPAB or nBx to nCPBA	2	1.5 1.5	0.9 0.7	ns
$t_h(\text{H})$ $t_h(\text{L})$	Hold time nAx to nCPAB or nBx to nCPBA	2	0.5 0.5	-0.6 -0.8	ns
$t_s(\text{H})$ $t_s(\text{L})$	Setup time nCEAB to nCPAB, nCEBA to nCPBA	2	1.1 0.5	0.2 -0.6	ns
$t_h(\text{H})$ $t_h(\text{L})$	Hold time nCEAB to nCPAB, nCEBA to nCPBA	2	1.5 1.0	0.6 -0.1	ns
$t_w(\text{H})$ $t_w(\text{L})$	nCPAB or nCPBA pulse width, High or Low	1	3.2 3.2	2.7 2.5	ns

2.5V/3.3V 16-bit registered transceiver (3-State)

74ALVT16952

DC ELECTRICAL CHARACTERISTICS (2.5V ± 0.2V RANGE)

SYMBOL	PARAMETER	TEST CONDITIONS	LIMITS			UNIT
			Temp = -40°C to +85°C			
			MIN	TYP ¹	MAX	
V _{IK}	Input clamp voltage	V _{CC} = 2.3V; I _{IK} = -18mA		-0.85	-1.2	V
V _{OH}	High-level output voltage	V _{CC} = 2.3 to 3.6V; I _{OH} = -100μA	V _{CC} -0.2	V _{CC}		V
		V _{CC} = 2.3V; I _{OH} = -8mA	1.8	2.1		
V _{OL}	Low-level output voltage	V _{CC} = 2.3V; I _{OL} = 100μA		0.07	0.2	V
		V _{CC} = 2.3V; I _{OL} = 24mA		0.3	0.5	
		V _{CC} = 2.3V; I _{OL} = 8mA		0.3	0.4	
I _I	Input leakage current	V _{CC} = 2.7V; V _I = V _{CC} or GND	Control pins	0.1	±1	μA
		V _{CC} = 0 or 2.7V; V _I = 5.5V		0.1	10	
		V _{CC} = 2.7V; V _I = 5.5V	Data pins ⁴	0.1	10	
		V _{CC} = 2.7V; V _I = V _{CC}		0.1	1	
		V _{CC} = 2.7V; V _I = 0		0.1	-5	
I _{OFF}	Off current	V _{CC} = 0V; V _I or V _O = 0 to 4.5V		0.1	±100	μA
I _{HOLD}	Bus Hold current A or B inputs ⁶	V _{CC} = 2.5V; V _I = 0.7V		110		μA
		V _{CC} = 2.5V; V _I = 1.7V		-6		μA
I _{EX}	Current into an output in the High state when V _O > V _{CC}	V _O = 5.5V; V _{CC} = 2.3V		50	125	μA
I _{PU/PD}	Power up/down 3-State output current ³	V _{CC} ≤ 1.2V; V _O = 0.5V to V _{CC} ; V _I = GND or V _{CC} ; OE/OE = Don't care		40	100	μA
I _{CCH}	Quiescent supply current	V _{CC} = 2.7V; Outputs High, V _I = GND or V _{CC} , I _O = 0		0.04	0.1	mA
I _{CCL}		V _{CC} = 2.7V; Outputs Low, V _I = GND or V _{CC} , I _O = 0		2.5	4.5	
I _{CCZ}		V _{CC} = 2.7V; Outputs Disabled; V _I = GND or V _{CC} , I _O = 0 ⁵		0.04	0.1	
ΔI _{CC}	Additional supply current per input pin ²	V _{CC} = 2.3V to 2.7V; One input at V _{CC} -0.6V, Other inputs at V _{CC} or GND		0.01	0.4	mA

NOTES:

- All typical values are at V_{CC} = 2.5V and T_{amb} = 25°C.
- This is the increase in supply current for each input at the specified voltage level other than V_{CC} or GND
- This parameter is valid for any V_{CC} between 0V and 1.2V with a transition time of up to 10msec. From V_{CC} = 1.2V to V_{CC} = 2.5V ± 0.3V a transition time of 100μsec is permitted. This parameter is valid for T_{amb} = 25°C only.
- Unused pins at V_{CC} or GND.
- I_{CCZ} is measured with outputs pulled up to V_{CC} or pulled down to ground.
- Bus hold current is not specified below V_{CC} =

2.5V/3.3V 16-bit registered transceiver (3-State)

74ALVT16952

AC CHARACTERISTICS (2.5V ± 0.2V RANGE)

GND = 0V; $t_R = t_F = 2.5\text{ns}$; $C_L = 50\text{pF}$, $R_L = 500\Omega$; $T_{\text{amb}} = -40^\circ\text{C}$ to $+85^\circ\text{C}$

SYMBOL	PARAMETER	WAVEFORM	LIMITS			UNIT
			$V_{CC} = 2.5V \pm 0.2V$			
			MIN	TYP ¹	MAX	
f_{MAX}	Maximum clock frequency	1	125	156		MHz
t_{PLH} t_{PHL}	Propagation delay nCPBA to nAx, nCPAB to nBx	1	1.0 1.0	3.0 3.0	3.8 3.9	ns
t_{PZH} t_{PZL}	Output enable time nOEBA to nAx, nOEAB to nBx	3 4	1.0 0.5	3.5 2.5	5.0 3.7	ns
t_{PHZ} t_{PLZ}	Output disable time nOEBA to nAx, nOEAB to nBx	3 4	1.0 1.0	3.9 3.1	4.8 4.1	ns

NOTES:

1. All typical values are at $V_{CC} = 2.5V$ and $T_{\text{amb}} = 25^\circ\text{C}$

AC SETUP REQUIREMENTS (2.5V ± 0.2V RANGE)

GND = 0V; $t_R = t_F = 2.5\text{ns}$; $C_L = 50\text{pF}$, $R_L = 500\Omega$; $T_{\text{amb}} = -40^\circ\text{C}$ to $+85^\circ\text{C}$

SYMBOL	PARAMETER	WAVEFORM	LIMITS		UNIT
			$V_{CC} = 2.5V \pm 0.2V$		
			MIN	TYP	
$t_s(H)$ $t_s(L)$	Setup time nAx to nCPAB or nBx to nCPBA	2	1.5 2.0	0.8 1.2	ns
$t_h(H)$ $t_h(L)$	Hold time nAx to nCPAB or nBx to nCPBA	2	0.5 0.5	-1.2 -0.8	ns
$t_s(H)$ $t_s(L)$	Setup time nCEAB to nCPAB, nCEBA to nCPBA	2	1.0 1.0	0.0 -0.2	ns
$t_h(H)$ $t_h(L)$	Hold time nCEAB to nCPAB, nCEBA to nCPBA	2	1.1 1.1	0.3 0.2	ns
$t_w(H)$ $t_w(L)$	nCPAB or nCPBA pulse width, High or Low	1	3.2 2.0	2.7 1.5	ns

AC WAVEFORMS

$V_M = 1.5V$, $V_{IN} = \text{GND to } 3.0V$

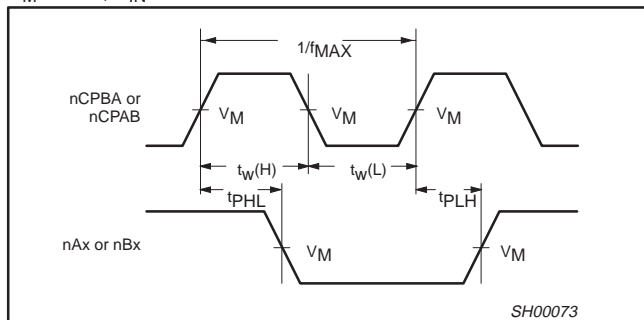

Waveform 1. Propagation Delay, Clock Input to Output, Clock Pulse Width, and Maximum Clock Frequency

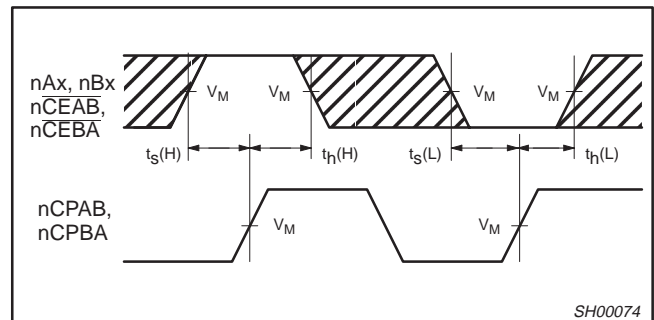

Waveform 2. Data Setup and Hold Times

2.5V/3.3V 16-bit registered transceiver (3-State)

74ALVT16952

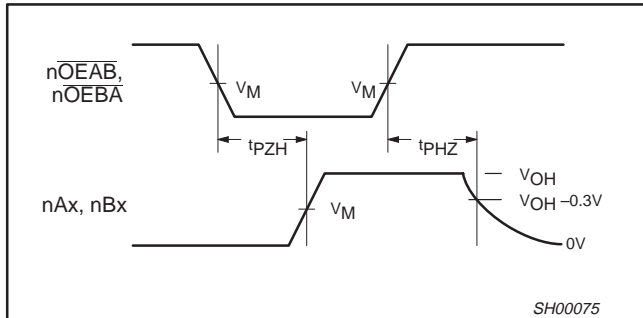

Waveform 3. 3-State Output Enable Time to High Level and Output Disable Time from High Level

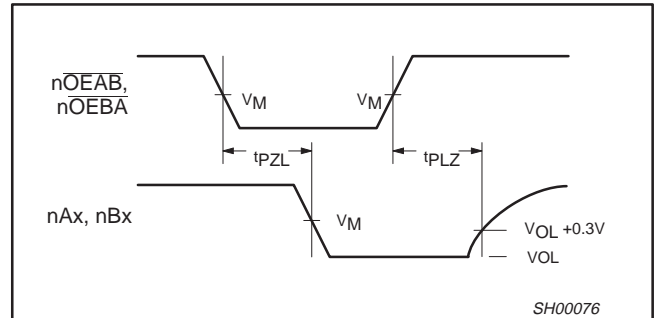

Waveform 4. 3-State Output Enable Time to Low Level and Output Disable Time from Low Level

TEST CIRCUIT AND WAVEFORMS

Test Circuit for 3-State Outputs

SWITCH POSITION

TEST	SWITCH
t_{PLZ}/t_{PZL}	6V or $V_{CC} \times 2$
t_{PLH}/t_{PHL}	Open
t_{PHZ}/t_{PZH}	GND

DEFINITIONS

R_L = Load resistor; see AC CHARACTERISTICS for value.

C_L = Load capacitance includes jig and probe capacitance: See AC CHARACTERISTICS for value.

R_T = Termination resistance should be equal to Z_{OUT} of pulse generators.

SW00025

FAMILY	INPUT PULSE REQUIREMENTS				
	Amplitude	Rep. Rate	t_W	t_R	t_F
74ALVT16	3.0V or V_{CC} whichever is less	$\leq 10\text{MHz}$	500ns	$\leq 2.5\text{ns}$	$\leq 2.5\text{ns}$

2.5V/3.3V ALVT 16-bit registered transceiver
(3-State)

74ALVT16952

SSOP56: plastic shrink small outline package; 56 leads; body width 7.5 mm

SOT371-1

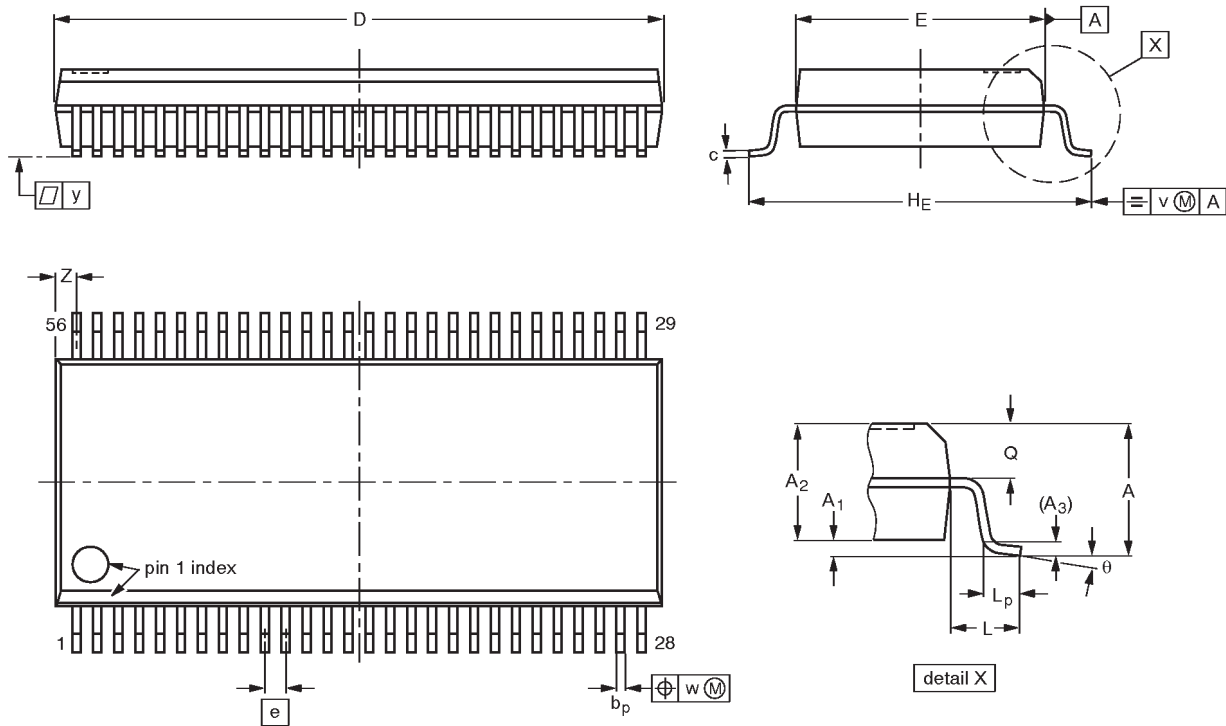

DIMENSIONS (mm are the original dimensions)

UNIT	A max.	A ₁	A ₂	A ₃	b _p	c	D ⁽¹⁾	E ⁽¹⁾	e	H _E	L	L _p	Q	v	w	y	Z ⁽¹⁾	θ
mm	2.8	0.4 0.2	2.35 2.20	0.25	0.3 0.2	0.22 0.13	18.55 18.30	7.6 7.4	0.635	10.4 10.1	1.4	1.0 0.6	1.2 1.0	0.25	0.18	0.1	0.85 0.40	8° 0°

Note

1. Plastic or metal protrusions of 0.25 mm maximum per side are not included.

OUTLINE VERSION	REFERENCES				EUROPEAN PROJECTION	ISSUE DATE
	IEC	JEDEC	EIAJ			
SOT371-1		MO-118AB				93-11-02 95-02-04

2.5V/3.3V ALVT 16-bit registered transceiver (3-State)

74ALVT16952

TSSOP56: plastic thin shrink small outline package; 56 leads; body width 6.1mm

SOT364-1

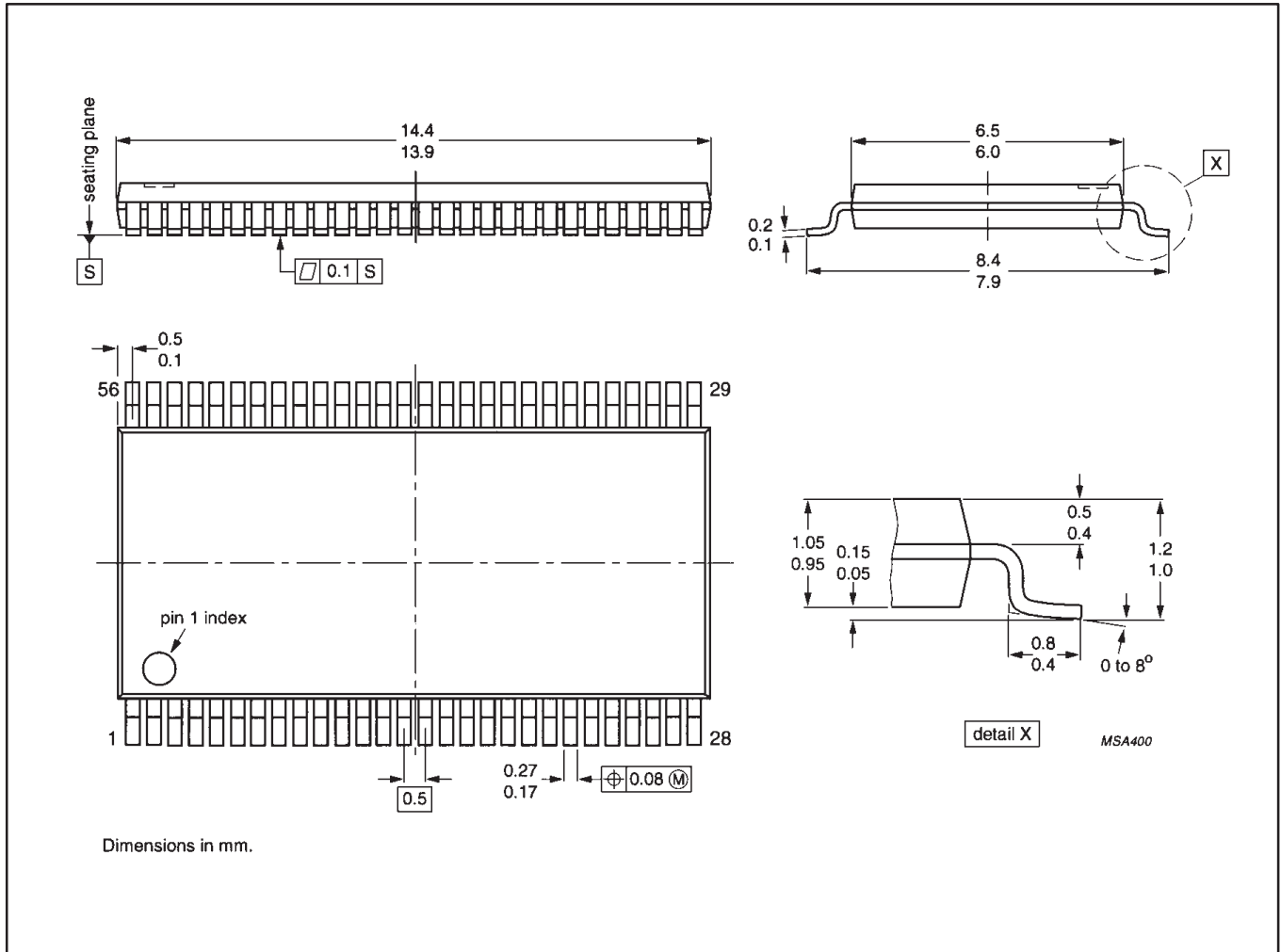

2.5V/3.3V ALVT 16-bit registered transceiver
(3-State)

74ALVT16952

NOTES

2.5V/3.3V ALVT 16-bit registered transceiver 3-State

74ALVT16952

Data sheet status

Data sheet status	Product status	Definition ^[1]
Objective specification	Development	This data sheet contains the design target or goal specifications for product development. Specification may change in any manner without notice.
Preliminary specification	Qualification	This data sheet contains preliminary data, and supplementary data will be published at a later date. Philips Semiconductors reserves the right to make changes at any time without notice in order to improve design and supply the best possible product.
Product specification	Production	This data sheet contains final specifications. Philips Semiconductors reserves the right to make changes at any time without notice in order to improve design and supply the best possible product.

[1] Please consult the most recently issued datasheet before initiating or completing a design.

Definitions

Short-form specification — The data in a short-form specification is extracted from a full data sheet with the same type number and title. For detailed information see the relevant data sheet or data handbook.

Limiting values definition — Limiting values given are in accordance with the Absolute Maximum Rating System (IEC 134). Stress above one or more of the limiting values may cause permanent damage to the device. These are stress ratings only and operation of the device at these or at any other conditions above those given in the Characteristics sections of the specification is not implied. Exposure to limiting values for extended periods may affect device reliability.

Application information — Applications that are described herein for any of these products are for illustrative purposes only. Philips Semiconductors make no representation or warranty that such applications will be suitable for the specified use without further testing or modification.

Disclaimers

Life support — These products are not designed for use in life support appliances, devices or systems where malfunction of these products can reasonably be expected to result in personal injury. Philips Semiconductors customers using or selling these products for use in such applications do so at their own risk and agree to fully indemnify Philips Semiconductors for any damages resulting from such application.

Right to make changes — Philips Semiconductors reserves the right to make changes, without notice, in the products, including circuits, standard cells, and/or software, described or contained herein in order to improve design and/or performance. Philips Semiconductors assumes no responsibility or liability for the use of any of these products, conveys no license or title under any patent, copyright, or mask work right to these products, and makes no representations or warranties that these products are free from patent, copyright, or mask work right infringement, unless otherwise specified.

Philips Semiconductors
811 East Arques Avenue
P.O. Box 3409
Sunnyvale, California 94088-3409
Telephone 800-234-7381

© Copyright Philips Electronics North America Corporation 1998
All rights reserved. Printed in U.S.A.

print code

Date of release: 05-96

Document order number:

9397-750-03581

Let's make things better.