



### FEATURES

- High Power Levels
- High Efficiency
- True Surface Mount Package With Integrated Heat Slug
- Internal Bias Circuit Requiring Nominal Input Voltages  $\pm 10\%$
- Low Cost
- Off Chip Output Matching Circuit Allows Application Optimization

### APPLICATIONS

- Base Station Driver Amplifier
- u-Cell Base Station Output Stage
- Cellular Booster Amplifier



### PRODUCT DESCRIPTION

The AWT921 is a monolithic amplifier for use in communication systems that require high gain and output intercept point. This device has been specifically designed for multi-carrier and micro-cell base station applications. This device is

manufactured on a high power MESFET process and has an on-chip bias circuit that does not require highly regulated positive and negative supplies to establish the proper operating point.

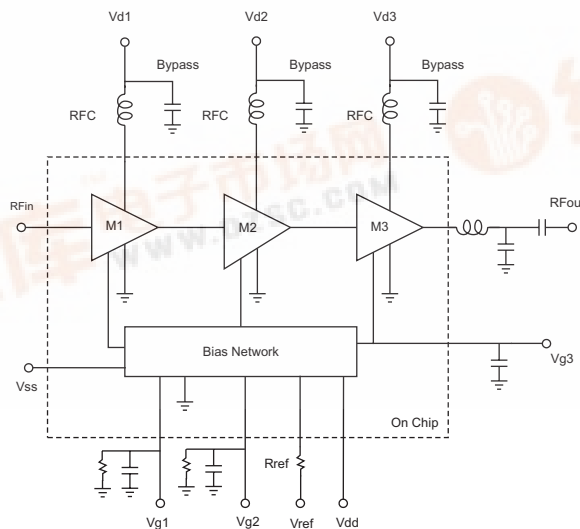

Figure 1: Block Diagram



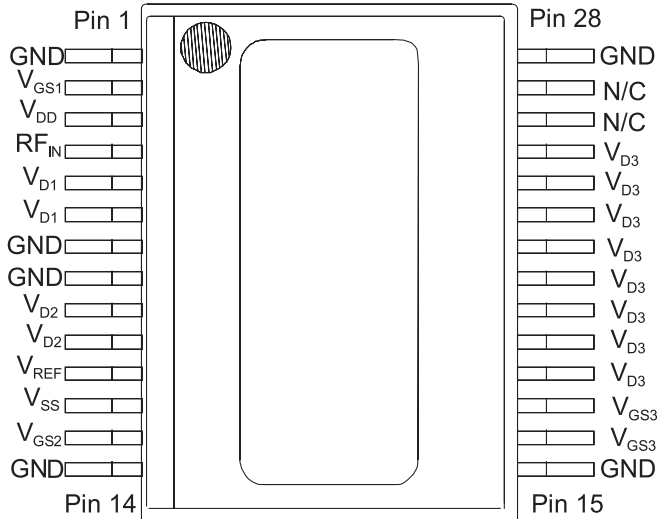

Figure 2: Pinout (X-Ray Top View)

Table 1: Pin Description

PIN	NAME	DESCRIPTION
1,14,15 28, slug	GND	AC and RF Ground
2	V <sub>GS1</sub>	First Stage Gate Terminal
3	V <sub>DD</sub>	Positive Supply of Bias Circuit
4	RF <sub>IN</sub>	RF Input
5,6	V <sub>D1</sub>	First Stage Drain Supply
7,8	GND	First Stage Source Ground
9,10	V <sub>D2</sub>	Second Stage Drain Supply
11	V <sub>REF</sub>	Bias Control Pin
12	V <sub>SS</sub>	Negative Supply for Bias Circuit
13	V <sub>GS2</sub>	Second Stage Gate Terminal
16,17	V <sub>GS3</sub>	Third Stage Gate Terminal
18-25	V <sub>D3</sub>	Third stage Drain Supply & RF <sub>OUT</sub>
26,27	N/C	Not Connected

## ELECTRICAL CHARACTERISTICS

Table 2: Absolute Minimum and Maximum Ratings

PARAMETER	MIN	MAX	UNIT
$V_{DD}$	0	+7	$V_{DC}$
$RF_{IN}$	0	+20	dBm
1st Stage Supply ( $V_{D1}$ )	0	+10	$V_{DC}$
2nd Stage Supply ( $V_{D2}$ )	0	+10	$V_{DC}$
3rd Stage Voltage ( $V_{D3}$ )	0	+10	$V_{DC}$
Negative Supply ( $V_{SS}$ )	-7	0	$V_{DC}$
Reference Voltage ( $V_{REF}$ )	0	+7	$V_{DC}$
Storage Temperature	-55	+100	°C
Operating Temperature	-30	+85	°C

Stresses in excess of the absolute ratings may cause permanent damage. Functional operation is not implied under these conditions. Exposure to absolute ratings for extended periods of time may adversely affect reliability.

Table 3: Operating Ranges

PARAMETER	MIN	TYP	MAX	UNIT
Operating Frequency	925	-	960	MHz
$RF_{IN}$	0	-	+14	dBm
1st Stage Supply ( $V_{D1}$ )	0	+8.5	+9	$V_{DC}$
2nd Stage Supply ( $V_{D2}$ )	0	+8.5	+9	$V_{DC}$
3rd Stage Voltage ( $V_{D3}$ )	0	+8.5	+9	$V_{DC}$
Reference Voltage ( $V_{REF}$ )	0	+5	+7	$V_{DC}$
Negative Supply ( $V_{SS}$ )	-7	-3	-2.7	$V_{DC}$
Operating Temperature	-30	-	+85	°C

The device may be operated safely over these conditions; however, parametric performance is guaranteed only over the conditions defined in the electrical specifications.

**Table 4: Electrical Specifications <sup>(1)</sup>**  
**( P<sub>in</sub> = +12dBm, fo = 925-960 MHz, V<sub>ds1</sub>=V<sub>ds2</sub>=V<sub>ds3</sub>=8.5V, V<sub>ss</sub> = -5 V,**  
**V<sub>REF</sub> = +25 V, V<sub>DD</sub> = +5 V, T<sub>c</sub> = +25 °C, 50 Ω system<sup>(2)</sup>)**

PARAMETER	SYMBOL	MIN	TYP	MAX	UNIT
Frequency	fo	925	-	960	MHz
Power Output	P <sub>OUT</sub>	-	+39	-	dBm
Power Added Efficiency	η <sub>EFF</sub>	-	40	-	%
Gain @P <sub>OUT</sub> = +39 dBm @P <sub>OUT</sub> = +30 dBm	PG	- -	27 31	- -	dB
Harmonics <sup>(3)</sup> 2nd 3rd 4th		- - -	37 47 50	- - -	dBc
Stability: -60 dBc all spurious outputs relative to desired signal	-	-	3:1	-	VSWR load, all phase angles
Bias Supply Currents	I <sub>SS</sub> I <sub>REF</sub> I <sub>DD</sub>	- - -	8 1.2 8	- - -	mA
Quiescent Currents	I <sub>DQ1</sub> I <sub>DQ2</sub> I <sub>DQ3</sub>	- - -	100 250 200	- - -	mA
Input Return Loss	-	10	-	-	dB
Gain Flatness @ P <sub>OUT</sub> = +39dBm @ P <sub>OUT</sub> = +30 dBm	ΔPG	0.5 0.5	- -	- -	dB
Thermal Resistance <sup>(4)</sup>		-	4.5	-	C/W

Notes:

(1) As measured in ANADIGICS test fixture, see application section.

(2) 50 Ω Measurement system after off chip matching circuit, input terminated in 50 Ω.

(3) Measured at P<sub>OUT</sub> = +39 dBm.

(4) Thermal resistance for junction to bottom of slug.  $\theta_{jc} = (T_j - T_c) / ((I_{D1} + I_{D2} + I_{D3}) * V_{SUP} - P_{OUT})$

PERFORMANCE DATA

Figure 3: Output Power and Power Added Efficiency vs. Pin

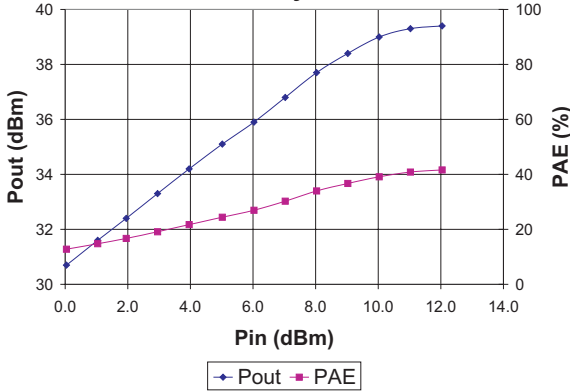

Figure 4: Output Power and Power Added Efficiency vs. Frequency

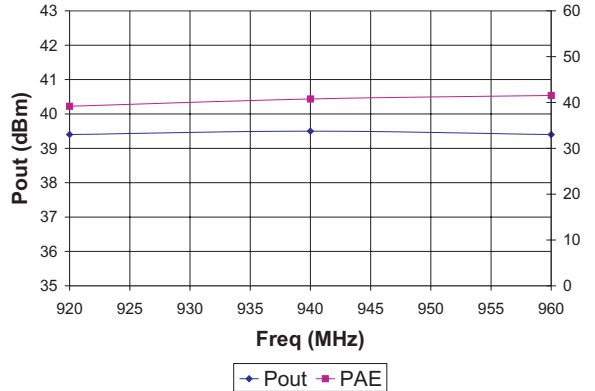

Figure 5: Output Power and PAE vs. Supply Voltage

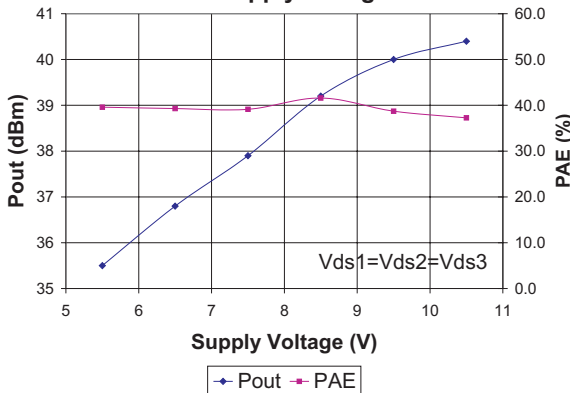

Figure 6: Third Stage Quiescent Current vs. Reference Voltage with Various RREF

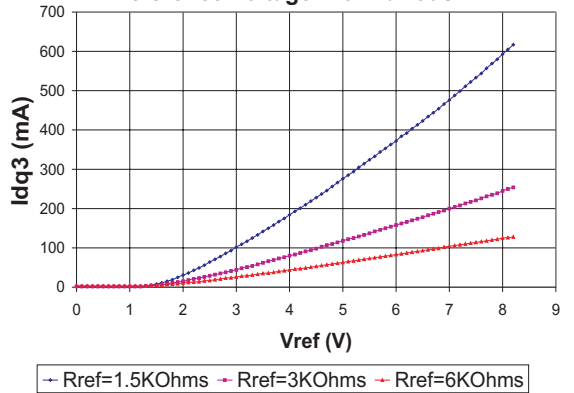

Figure 7: Third Stage Quiescent Current vs. VDD, RREF = 1.8 KΩ

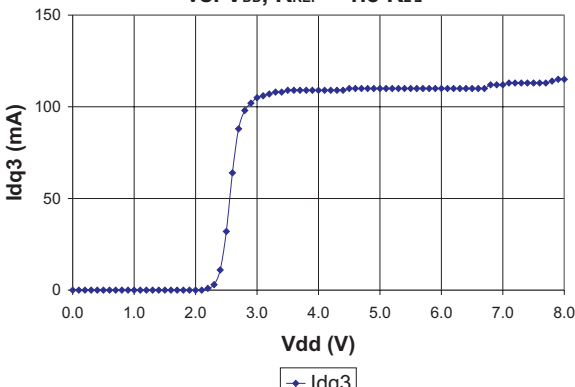
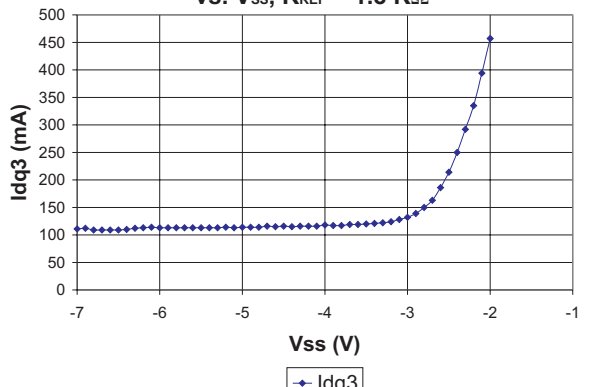
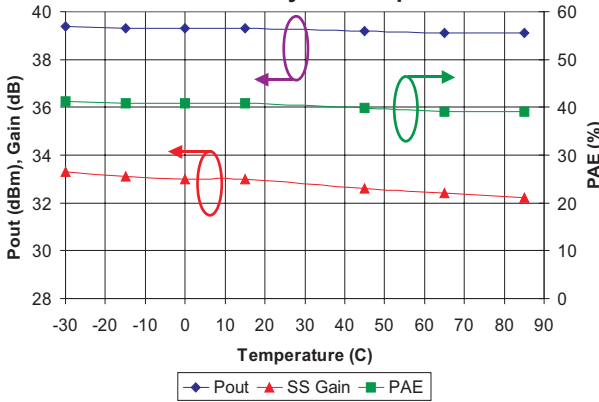

Figure 8: Third Stage Quiescent Current vs. VSS, RREF = 1.8 KΩ



**Figure 9: Small Signal Gain, Saturated Power, and Efficiency vs. Temperature**



**Figure 10: Third Stage Quiescent Current, Reference Current vs. Temperature**

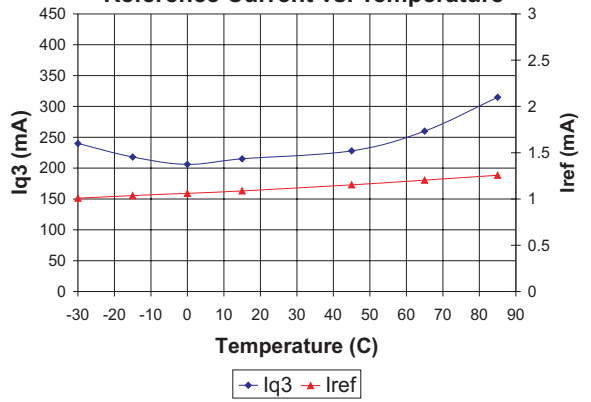

**Figure 11: Test Circuit Impedance Presented to the First Stage Drain (Vd1)**

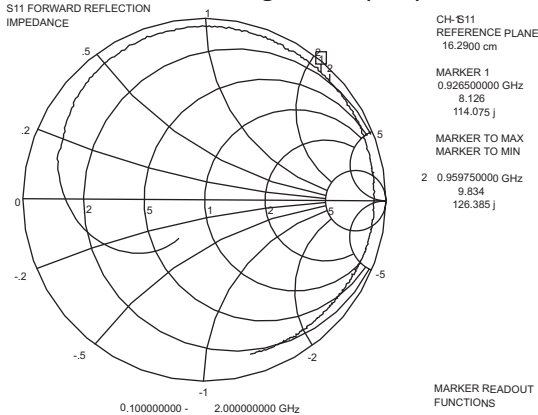

**Figure 12: Test Circuit Impedance Presented to the Second Stage Drain (Vd2)**

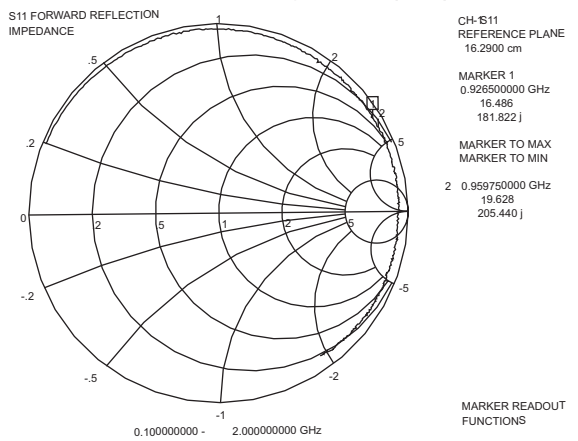

**Figure 13: Test Circuit Impedance Presented to the Third Stage Drain (Vd3)**

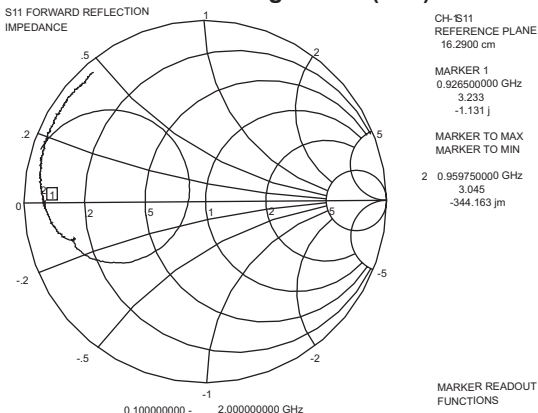

APPLICATION INFORMATION

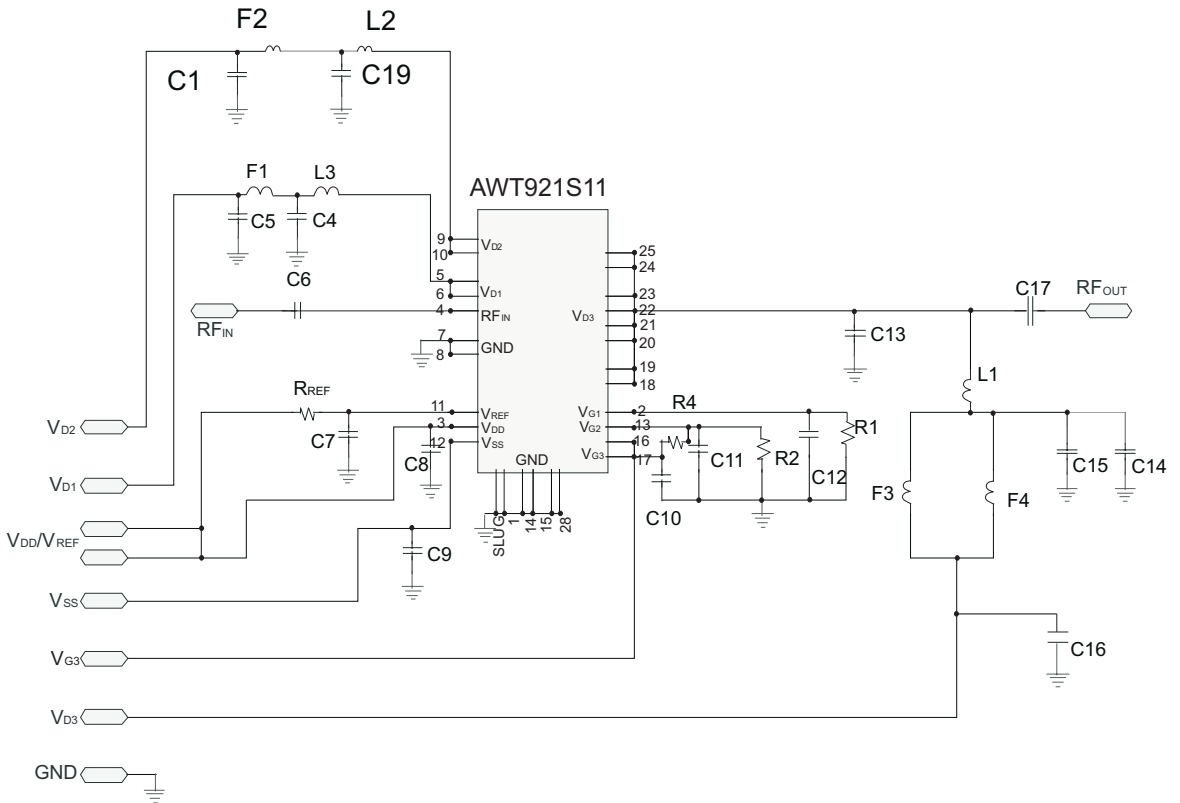
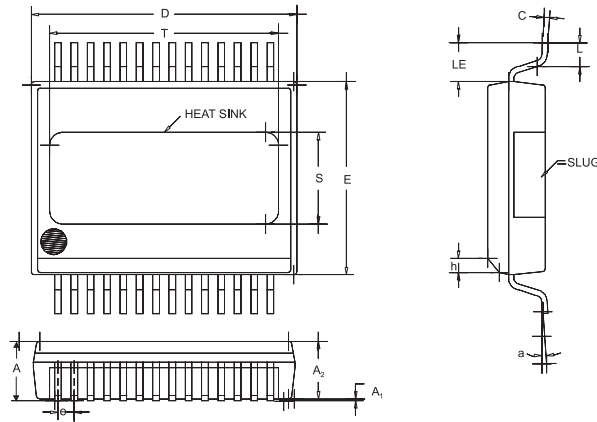

Figure 14: Application Circuit Schematic

Table 5: Application Circuit Component Values  
(925-960 MHz GSM Application)

DESIGNATION	VALUE	DESIGNATION	VALUE
R1	7500 Ω	C10, C11	2700 pF
R2	2.2 KΩ	C13	11 pF
R <sub>REF</sub>	1.8 KΩ	C14	4700 pF
C1, C5, C16	2.2 μF	L1	8 nH Colicraft, A03T
C4, C15, C19	33 pF	L2	12 nH
C6, C17	47 pF	L3	6 nH
C7, C8, C9, C12	0.01 μF	F1, F2, F3, F4,	Ferrite 47 Ω @ 100 MHz, 1A Rating Taiyo Yuden, BK2125HS470

**AWT921**  
**PACKAGE OUTLINE**



SYMBOL	INCHES		MILLIMETERS		NOTE
	MIN.	MAX.	MIN.	MAX.	
A	0.087	0.093	2.21	2.36	
A <sub>1</sub>	0.000	0.004	0.00	0.10	
A <sub>2</sub>	0.087	0.089	2.21	2.25	
B	0.008	0.012	0.36	0.46	
C	0.007	0.009	0.18	0.25	
D	0.400	0.408	10.16	10.36	2
E	0.292	0.296	7.42	7.52	2
e	0.025	BSC	0.64	BSC	4
H	0.410	0.418	10.41	40.62	
h	0.018	0.024	0.48	0.61	
L	0.034	0.038	0.86	0.97	
LE	0.84		1.37		
a	0	8	0	8	
S	0.139	0.141	3.54	3.55	5
T	0.349	0.351	8.86	8.92	5

- NOTES:
1. CONTROLLING DIMENSIONS - INCHES
  2. DIMENSION "D" DOES NOT INCLUDE MOLD FLASH, PROTRUSIONS OR GATE BURRS. MOLD FLASH, PROTRUSIONS AND GATE BURRS SHALL NOT EXCEED 0.006 (0.16mm)
  3. DIMENSION "E" DOES NOT INCLUDE INTER-LEAD OR PROTRUSIONS. INTER-LEAD FLASH AND PROTRUSIONS SHALL NOT EXCEED 0.010 (0.25mm) PER SIDE.
  4. MAXIMUM LEAD TWIST/SKEW TO BE 0.002 (0.05mm)
  5. MOLD FLASH SHALL NOT EXTEND MORE THAN 0.010 (0.25mm) ON ANY EDGE OF HEAT SLUG

**Figure 15: S11 Package Outline - 28 Pin SSOP 28 Thermal Slug Package**

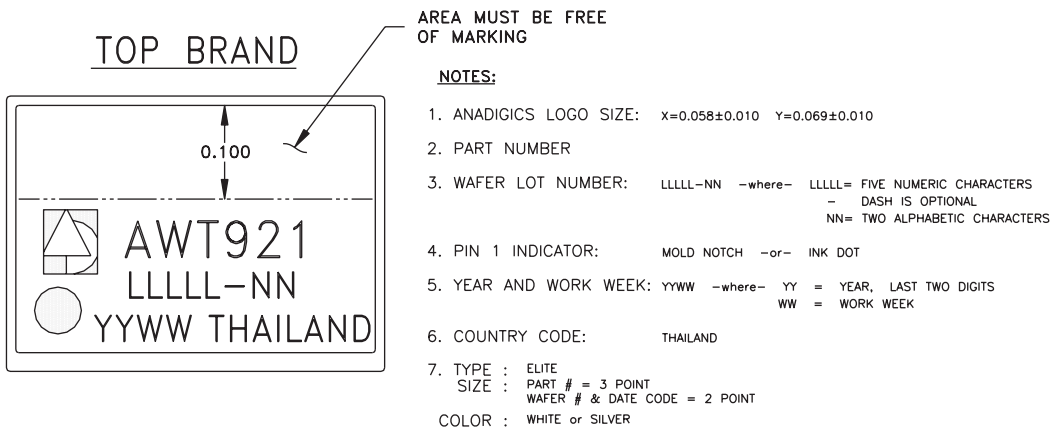

**Figure 16: Branding Specification**



COMPONENT PACKAGING

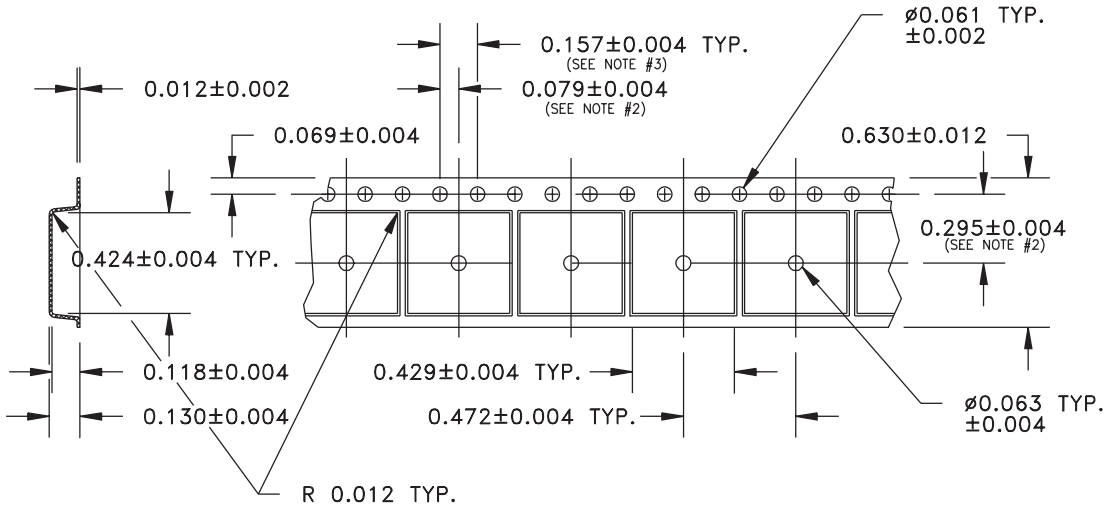

- NOTES: 1. MATERIAL - CONDUCTIVE POLYSTYRENE.  
 2. MEASURED FROM CENTERLINE OF SPROCKET HOLE TO CENTERLINE OF POCKET.  
 3. CUMULATIVE TOLERANCE OF 10 SPROCKET HOLES IS ± 0.008.

ALL DIMENSIONS ARE IN INCHES

ALL DIMENSIONS ARE REFERENCE ONLY.  
 SEMIPAC CORP PART #  
 CPSO16WA3-22B3-65

CARRIER TAPE, CONDUCTIVE  
 SOIC 16 LD WIDE BODY PACKAGE  
 DWG. NO. 4475

Figure 17: Tape & Reel Drawing

Table 6: Tape & Reel Dimensions

PACKAGE TYPE	TAPE WIDTH	POCKET PITCH	REEL CAPACITY	MAX REEL DIA
SSOP-28 WIDE BODY	0.630 INCHES	0.472 INCHES	3500	13 INCHES

**AWT921**

**NOTES**

**AWT921**

**NOTES**

**AWT921**



**ANADIGICS, Inc.**

141 Mount Bethel Road

Warren, New Jersey 07059, U.S.A.

Tel: +1 (908) 668-5000

Fax: +1 (908) 668-5132

URL: <http://www.anadigics.com>

E-mail: [Mktg@anadigics.com](mailto:Mktg@anadigics.com)

**IMPORTANT NOTICE**

ANADIGICS, Inc. reserves the right to make changes to its products or to discontinue any product at any time without notice. The product specifications contained in Advanced Product Information sheets and Preliminary Data Sheets are subject to change prior to a product's formal introduction. Information in Data Sheets have been carefully checked and are assumed to be reliable; however, ANADIGICS assumes no responsibilities for inaccuracies. ANADIGICS strongly urges customers to verify that the information they are using is current before placing orders.

**WARNING**

ANADIGICS products are not intended for use in life support appliances, devices or systems. Use of an ANADIGICS product in any such application without written consent is prohibited.