

AX31002

Bipolar Tone Ringer IC

Description

The AX31002 is a bipolar integrated circuit. It is designed for telephone bell replacement. It can also be used as alarms or other alerting devices.

Features

- Current consumption is small
- Oscillation frequency is variable
- Adjustable start-up current
- Higher driving capability
- Built-in threshold circuits prevent false triggering due to power noise as well as 'chirps' due to rotary dial
- Few external components
- Easy connection to telephone system

Applications

- Telecom Tone Ringer Set

Pin Connections

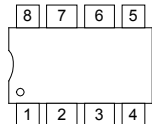
	Pin1: VCC	Pin5: Gnd
	Pin2: RSL Trigger In (RSL)	Pin6: High Freq. Time Constant. (HRC)
	Pin3: Low Freq. Time Constant. (LRC)	Pin7: High Freq. Time Constant. (HRC)
	Pin4: Low Freq. Time Constant. (LRC)	Pin8: Output

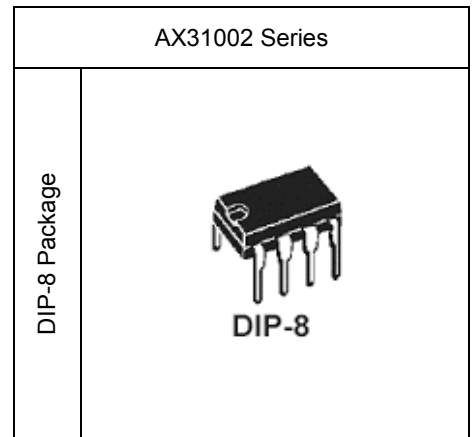

Absolute Maximum Rating (unless otherwise specified)

Characteristics	Symbol	Rating	Unit
Supply Voltage	V_{CC}	30	V
Power Dissipation	P_D	500	mW
Operating Temperature	T_{opr}	-25 ~ +85	°C
Storage Temperature	T_{stg}	-55 ~ +150	°C

Block Diagram

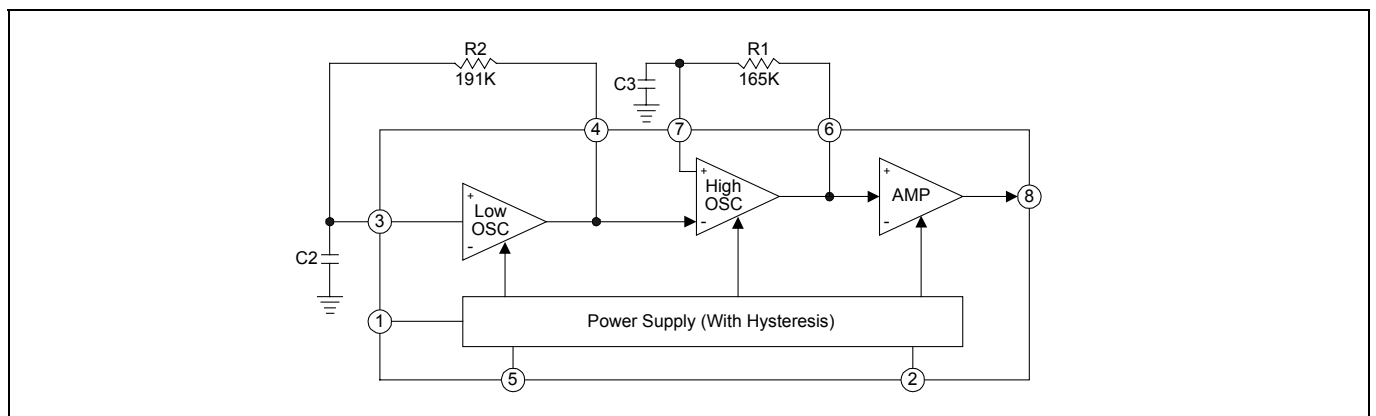

Electrical Characteristics

Characteristics		Symbol	Test Condition	Min.	Typ.	Max.	Unit
Operating Voltage		V_{opr}		-	-	29	V
Initiation Supply Voltage		V_{si}	(Note 1)	17	19	21	V
Sustaining Supply Voltage		V_{sus}	(Note 2)	10.5	12	13.5	V
Initiation Current Consumption		I_{si}	No Load	1.4	3.3	4.2	mA
Sustaining Current Consumption		I_{sus}	No Load	0.34	1.4	2.5	mA
Oscillator Frequency		f_L	$C_1=0.47\mu F, R_1=165k\Omega$	9	10	11	Hz
		f_{H1}	$C_2=6800pF, R_2=191k\Omega$	461	512	563	
		f_{H2}		576	640	703	
Output Voltage	"H" Level	V_{OH}	$V_{CC}=24V, I_{OH}=-10mA, Pin\ 7=GND$	20	21.5	22.5	V
	"L" Level	V_{OL}	$V_{CC}=24V, I_{OH}=10mA, Pin\ 7=7V$	0.7	1	2	V

Note 1: Initiation Supply Voltage (V_{si}) is a supply voltage required to start oscillation of the tone ringer.

Note 2: Sustaining Supply Voltage (V_{sus}) is a supply voltage required to maintain oscillation of the tone ringer.

Note 3: Oscillation frequency is determined by the following equations: (1) $f_L=1/1.234xR_1xC_1$ (Hz) (2) $f_{H1}=1/1.515xR_2xC_2$ (Hz) (3) $f_{H2}=1.24f_{H1}$ (Hz)

Characteristics Curve

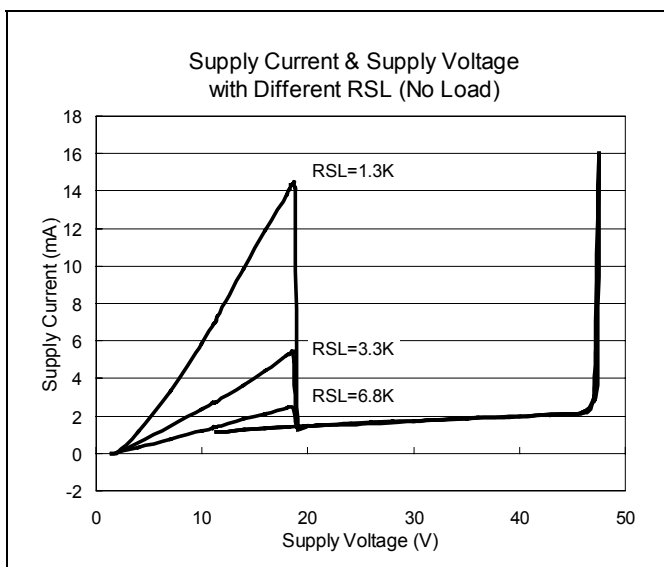
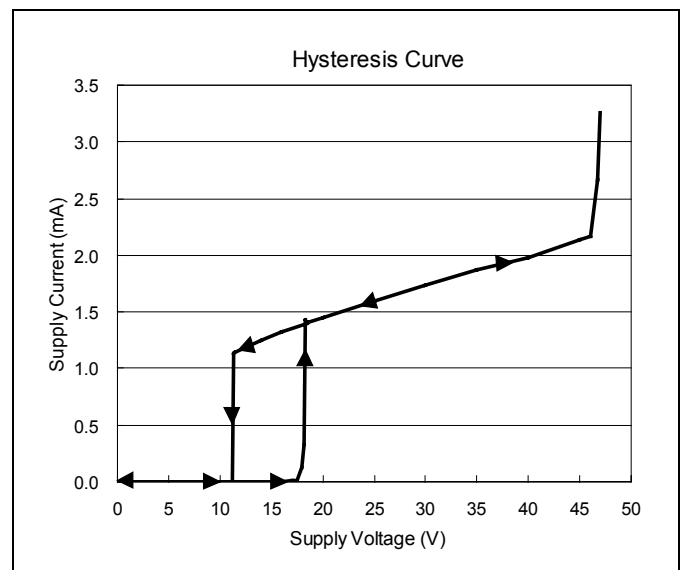
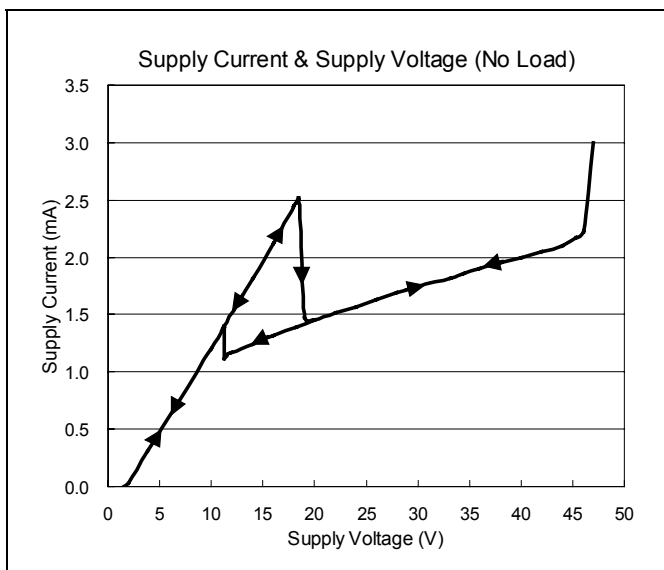

Application Information

- Application circuits of Telecom Tone Ringer Set

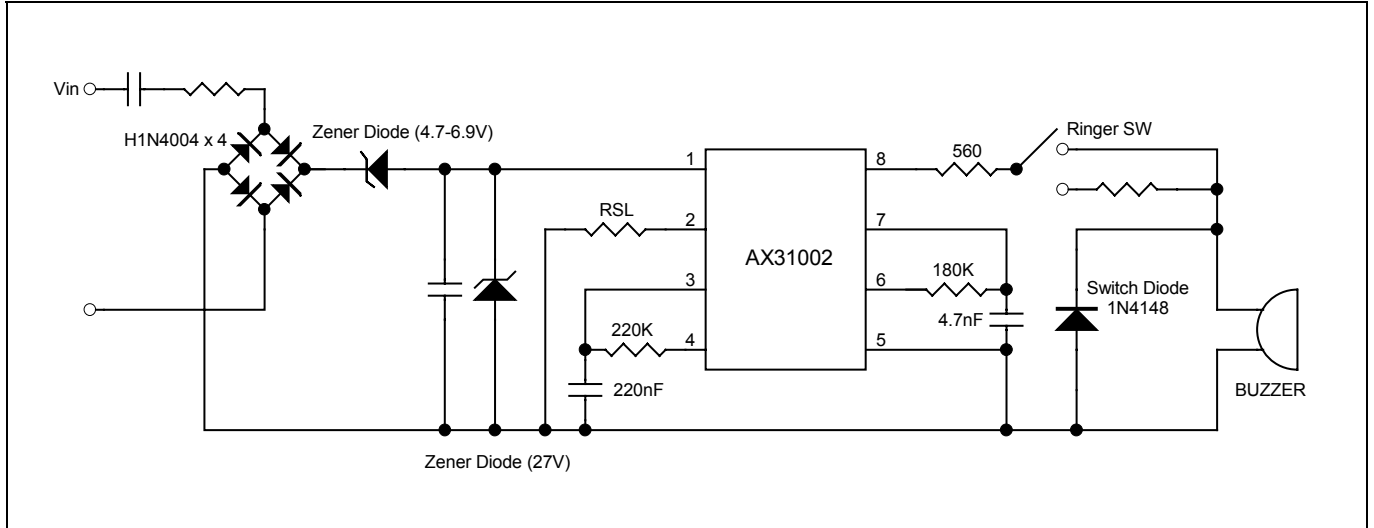

- Example of Output Circuit

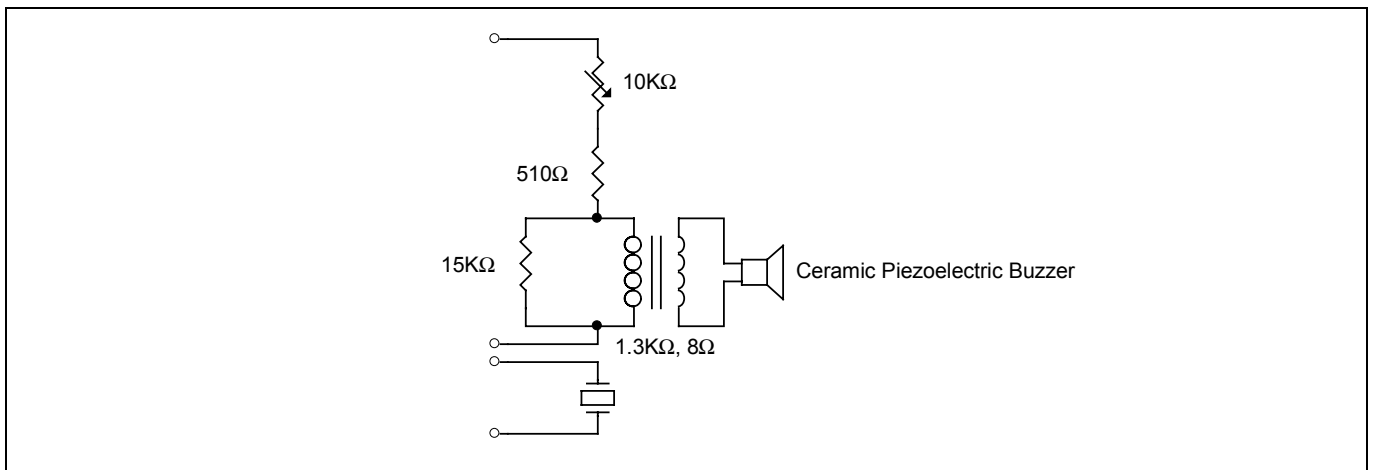

DIP-8 Dimension

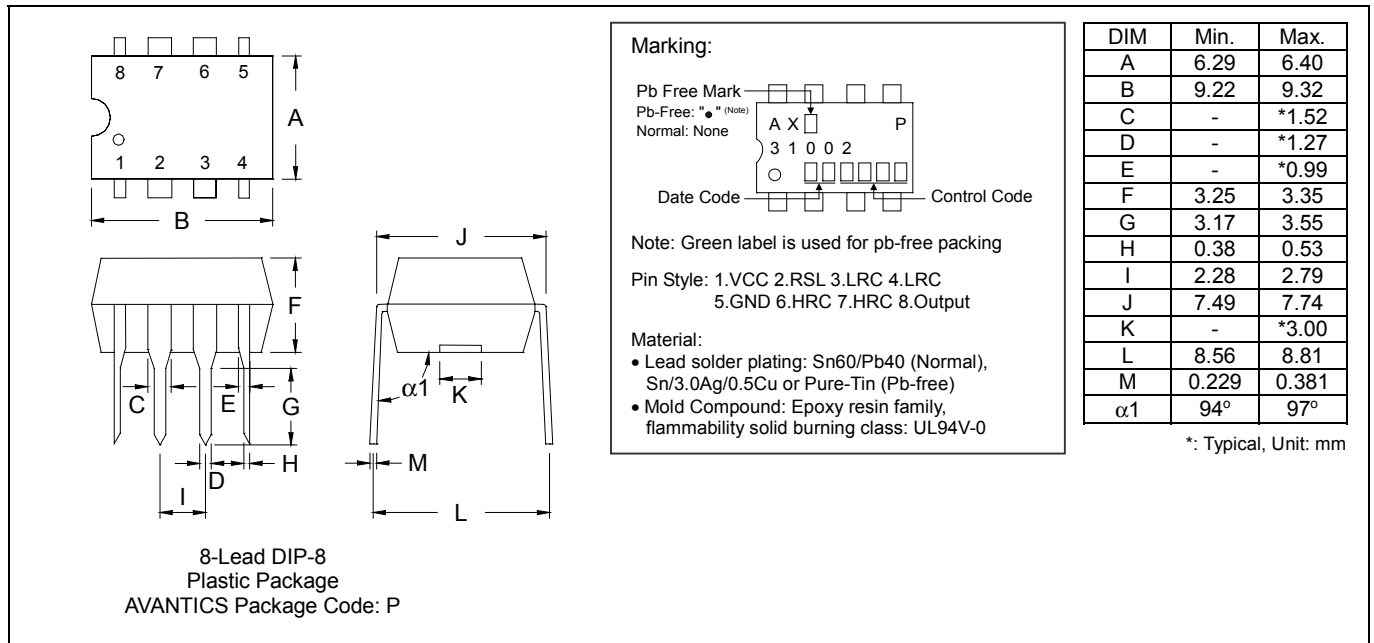

Important Notice:

- All rights are reserved. Reproduction in whole or in part is prohibited without the prior written approval of AVANTIC.
- AVANTICS reserves the right to make changes to its products without notice.
- **AVANTICS semiconductor products are not warranted to be suitable for use in Life-Support Applications, or systems.**
- AVANTICS assumes no liability for any consequence of customer product design, infringement of patents, or application assistance.

Head Office:

- AVANTICS Microelectronics Corp: No. 255, Cai Lun Rd. Zhangjiang Technology Industrial Park Pudong, Shanghai, China
 Tel: 86-021-58955599 Fax: 86-021-58558038

Soldering Methods for AVANTICS's Products

1. Storage environment: Temperature=10°C~35°C Humidity=65%±15%

2. Reflow soldering of surface-mount devices

Figure 1: Temperature profile

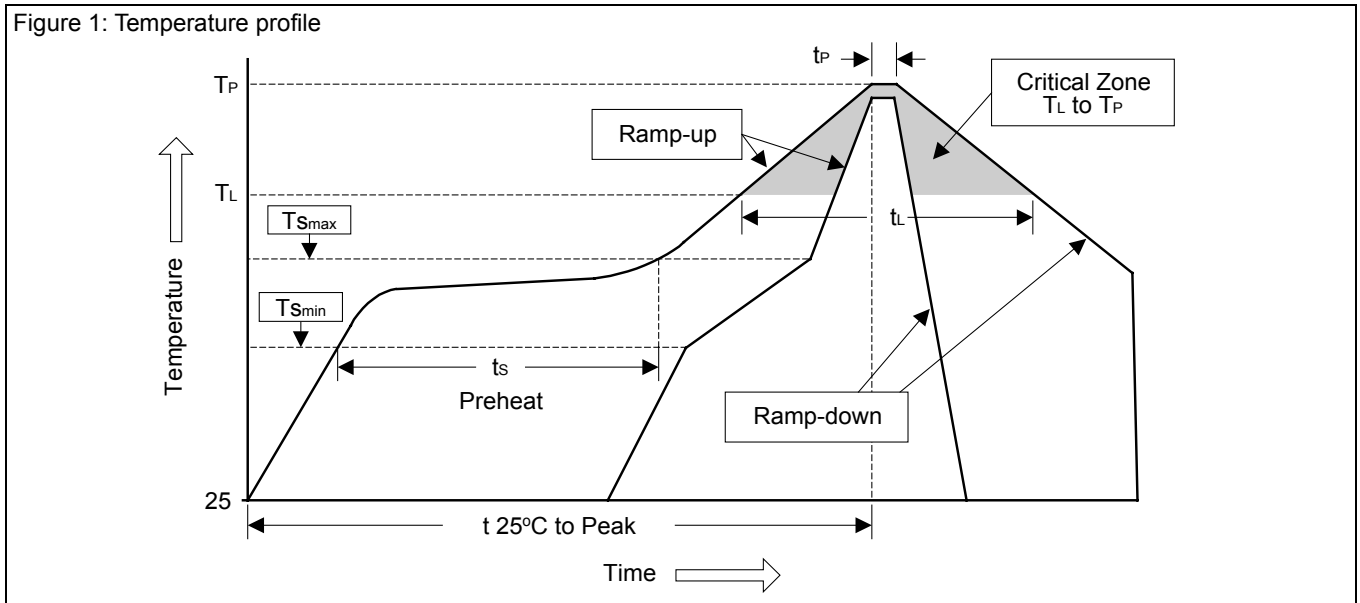

Profile Feature	Sn-Pb Eutectic Assembly	Pb-Free Assembly
Average ramp-up rate (T_L to T_P)	<3°C/sec	<3°C/sec
Preheat		
- Temperature Min (T_{smin})	100°C	150°C
- Temperature Max (T_{smax})	150°C	200°C
- Time (min to max) (t_s)	60~120 sec	60~180 sec
T_{smax} to T_L		
- Ramp-up Rate	<3°C/sec	<3°C/sec
Time maintained above:		
- Temperature (T_L)	183°C	217°C
- Time (t_L)	60~150 sec	60~150 sec
Peak Temperature (T_P)	240°C +0/-5°C	260°C +0/-5°C
Time within 5°C of actual Peak Temperature (t_p)	10~30 sec	20~40 sec
Ramp-down Rate	<6°C/sec	<6°C/sec
Time 25°C to Peak Temperature	<6 minutes	<8 minutes

3. Flow (wave) soldering (solder dipping)

Products	Peak temperature	Dipping time
Pb devices.	245°C ±5°C	5sec ±1sec
Pb-Free devices.	260°C +0/-5°C	5sec ±1sec