



High-Precision ADC Mixed-Signal Microcontroller

MAXQ3120

General Description

The MAXQ3120 microcontroller is a high-performance, 16-bit microcontroller that incorporates dual, true-differential, 16-bit sigma-delta analog-to-digital converters (ADCs), a liquid-crystal display (LCD) interface that can drive up to 112 segments, and a real-time clock (RTC) module with a dedicated battery-backup supply. The MAXQ3120 is uniquely suited for the single-phase electricity metering market, but can be used in any application that requires high-performance operation. The device can operate at a maximum of 8MHz (DVDD = 3.3V). The MAXQ3120 has 16kWords of flash memory, 256 words of RAM, three 16-bit timers, and two universal synchronous/asynchronous receiver/transmitters (USARTs). The microcontroller core and I/O are powered by a single 3.3V supply, and an additional battery supply keeps the RTC running during power outages.

Applications

Single-Phase Electricity Metering	Home Appliances
Battery-Powered and Portable Devices	Consumer Electronics
Electrochemical and Optical Sensors	Thermostats/Humidity Sensors
Industrial Control	Security Sensors
Data-Acquisition Systems and Data Loggers	Gas and Chemical Sensors
	HVAC
	Smart Transmitters

Ordering Information

PART	TEMP RANGE	PIN-PACKAGE
MAXQ3120-FFN	-40°C to +85°C	80 MQFP
MAXQ3120-FFN+	-40°C to +85°C	80 MQFP

+Denotes a Pb-free/RoHS-compliant device.

Selector Guide, Typical Operating Circuit, and Pin Configuration appear at end of data sheet.

MAXQ is a trademark of Maxim Integrated Products, Inc.

Note: Some revisions of this device may incorporate deviations from published specifications known as errata. Multiple revisions of any device may be simultaneously available through various sales channels. For information about device errata, go to: www.maxim-ic.com/errata.

Features

- ◆ **High-Performance, Low-Power, 16-Bit RISC Core**
DC to 8MHz Operation, Approaching 1MIPS per MHz
3.3V Core and I/O
33 Instructions, Most Single-Cycle
Three Independent Data Pointers Accelerate Data Movement with Automatic Increment/Decrement
16-Level Hardware Stack
16-Bit Instruction Word, 16-Bit Data Bus
16 x 16-Bit, General-Purpose Working Registers
Optimized for C-Compiler (High-Speed/Density Code)
- ◆ **Program and Data Memory**
16kWords Flash Memory
1,000,000 Flash Write/Erase Cycles
256 Words of Internal Data RAM
JTAG Bootloader for Programming
- ◆ **Dual, 16-Bit Sigma-Delta ADCs**
Differential Analog Input Channels
Programmable Gain of 1x or 16x
Integrated Sinc³ Filters
Digital Phase Compensation and Trimmable Bandgap Reference
- ◆ **Peripheral Features**
Up to 32 General-Purpose I/O Pins
112-Segment LCD Driver
Up to 4 COM and 28 Segments
Static, 1/2, and 1/3 LCD Bias Supported
No External Resistors Required
Two Serial USARTs, One with Infrared PWM Support
One-Cycle, 16 x 16 Hardware Multiply/Accumulate with 40-Bit Accumulator
Three 16-Bit Programmable Timers/Counters, One with Infrared PWM Support
8-Bit, Subsecond, System Timer/Alarm
Battery-Backed, 32-Bit RTC with Time-of-Day Alarm and Digital Trim
Programmable Watchdog Timer
- ◆ **Flexible Programming Interface**
Bootloader Simplifies Programming
In-System Programming Through JTAG
Supports In-Application Programming of Flash Memory
- ◆ **Power Consumption**
< 28mA at 8MHz, 3.3V Flash Operation
320µA Standby Current in Sleep Mode
Low-Power Divide-by-256 Mode



High-Precision ADC Mixed-Signal Microcontroller

ABSOLUTE MAXIMUM RATINGS

Voltage Range on DV_{DD} Relative to DGND-0.3V to +4.0V
 Voltage Range on AV_{DD} Relative to AGND.....-0.3V to +4.0V
 Voltage Range on AGND Relative to DGND-0.3V to +0.3V
 Voltage Range on AV_{DD} Relative to DV_{DD}.....-0.3V to +0.3V
 Voltage Range on Any Pin Relative to DGND
 Except AN0+, AN0-, AN1+, AN1-.....-0.3V to (DV_{DD} + 0.5V)

Voltage Range on AN0+, AN0-, AN1+,
 AN1- Relative to AGND-4.0V to +4.0V
 Operating Temperature Range-40°C to +85°C
 Junction Temperature+150°C
 Storage Temperature Range-65°C to +150°C
 Soldering TemperatureSee IPC/JEDEC
 J-STD-020 Specification

Stresses beyond those listed under "Absolute Maximum Ratings" may cause permanent damage to the device. These are stress ratings only, and functional operation of the device at these or any other conditions beyond those indicated in the operational sections of the specifications is not implied. Exposure to absolute maximum rating conditions for extended periods may affect device reliability.

ELECTRICAL CHARACTERISTICS

(DV_{DD}, AV_{DD} = V_{RST} to 3.6V, V_{REF} = 1.25V (external), f_{HFXIN} = 8MHz, T_A = -40°C to +85°C, unless otherwise noted.) (Note 1)

PARAMETER	SYMBOL	CONDITIONS	MIN	TYP	MAX	UNITS
Digital Supply Voltage	DV _{DD}		V _{RST}	3.3	3.6	V
Digital Supply Ramp Rate		Can be controlled by placing a 1μF or higher capacitor between DV _{DD} and ground	-16		+16	V/ms
Digital Power-Fail Reset	V _{RST}		2.8	2.9	3.03	V
Active Current (Note 2)	I _{DD1}	/1 mode		21	28	mA
	I _{DD2}	/2 mode		11		
	I _{DD3}	/4 mode		5.7		
	I _{DD4}	/8 mode		3.1		
	I _{DD5}	PMM mode		1.0		
Stop-Mode Current (DV _{DD} plus AV _{DD})	I _{STOP}			320	760	μA
Battery Supply Voltage	V _{BAT}		1.8		3.8	V
Battery Current	I _{BAT}	RTCE = 1, DV _{DD} = 0V, V _{BAT} = 3.6V		5.1	10	μA
Input High Voltage	V _{IH}		0.7 x DV _{DD}		DV _{DD} + 0.3	V
Input Low Voltage	V _{IL}		-0.3		0.3 x DV _{DD}	V
Input Hysteresis (Schmitt)	V _{IHYS}			0.6		V
Output High Voltage (All Ports)	V _{OH}	I _{OH} = +1.5mA	DV _{DD} - 0.4			V
		I _{OH} = +2.5mA	DV _{DD} - 0.5			
Output Low Voltage (All Ports, RESET)	V _{OL}	I _{OL} = 3mA sink current	0.4			V
		I _{OL} = 3.65mA sink current	0.5			
Input Low Current (All Ports)	I _{IL}	V _{IL} = 0.4V; weak pullup enabled	-50			μA
RESET Pullup Resistance	R _{RST}		50	100	200	kΩ
Input Leakage (All Ports)	I _L	Weak pullup disabled	-1		+1	μA

High-Precision ADC Mixed-Signal Microcontroller

MAX93120

ELECTRICAL CHARACTERISTICS (continued)

(DV_{DD}, AV_{DD} = V_{RST} to 3.6V, V_{REF} = 1.25V (external), f_{HFXIN} = 8MHz, T_A = -40°C to +85°C, unless otherwise noted.) (Note 1)

PARAMETER	SYMBOL	CONDITIONS	MIN	TYP	MAX	UNITS
Analog Supply Voltage	AV _{DD}	AV _{DD} = DV _{DD}	2.8	3.3	3.6	V
Active Analog Supply Current	I _{AVDD}	Normal operation		2.65	3.5	mA
Power-Down Analog Supply Current		APD2:0 = 111b		250	635	μA
ANALOG-TO-DIGITAL CONVERTER DC ACCURACY						
ADC Resolution		No missing codes, with software lowpass filter (see Appendix A)		16		bits
Offset Error		Gain = 1		±5.0		mV
Gain Error		Gain = 1		±5.0		%
Gain-Error Drift				±10		ppm
Gain-Error Match				±0.5		%
DC Power-Supply Rejection	PSRR	AN0+, AN0- = AGND; AV _{DD} = 3.0V to 3.6V		80		dB
ANALOG-TO-DIGITAL CONVERTER DYNAMIC SPECIFICATIONS						
Signal-to-Noise Ratio	SNR	DV _{DD} = 3.3V, AV _{DD} = 3.3V, AN0 = 25mV, peak-to-peak sine wave at 65Hz, gain = 16	48	57		dB
		With software lowpass filter, cutoff at 21st harmonic (see Appendix A)		71		
		With software lowpass filter, cutoff at 7th harmonic (see Appendix A)		74		
Total Harmonic Distortion	THD	DV _{DD} = 3.3V, AV _{DD} = 3.3V, AN0 = 25mV, peak-to-peak sine wave at 65Hz, gain = 16 (up to 21st harmonic)		-79	-55	dB
ANALOG-TO-DIGITAL CONVERTER INPUTS						
Input-Voltage Range		AN0+, AN0-; AN1+, AN1- to AGND	-1		+1	V
Input Sampling Capacitance (Note 3)	C _{IN}	Channel 0	Gain = 1	1		pF
			Gain = 16	16		
Input Sampling Rate	f _S	(Note 4)		1.33		MHz
Sample Output Rate				f _{HFXIN} / 384		sample / sec
Input Impedance to AGND (Note 5)			Gain = 1	750		kΩ
			Gain = 16	46		
Differential Input Impedance (Note 6)			Gain = 1	1500		kΩ
			Gain = 16	93		
Input Bandwidth (-3dB)				5.5		kHz
Reference Input Voltage	V _{REF}		1.2	1.25	1.3	V
Reference Input Sampling Capacitance				2		pF
Reference Input Sampling Rate	f _S			1.33		MHz

High-Precision ADC Mixed-Signal Microcontroller

ELECTRICAL CHARACTERISTICS (continued)

(DV_{DD}, AV_{DD} = V_{RST} to 3.6V, V_{REF} = 1.25V (external), f_{HFXIN} = 8MHz, T_A = -40°C to +85°C, unless otherwise noted.) (Note 1)

PARAMETER	SYMBOL	CONDITIONS	MIN	TYP	MAX	UNITS
INTERNAL REFERENCE						
Reference Output Voltage				1.25		V
Reference-Output Temperature Coefficient		With V _{REF} bandgap trimming (ATRM[4:0] = 01111b)		±120		ppm/°C
				±35		
Load Regulation		I _{REF} = ±2μA, C _L = 12pF		±50	±500	μV/μA
LCD INTERFACE						
LCD Reference Voltage	V _{LCD}				DV _{DD}	V
LCD Bias Voltage 1	V _{LCD1}	Guaranteed by design		V _{ADJ} + 2/3 (V _{LCD} - V _{ADJ})		V
LCD Bias Voltage 2	V _{LCD2}	Guaranteed by design		V _{ADJ} + 1/3 (V _{LCD} - V _{ADJ})		V
LCD Adjustment Voltage (Note 7)	V _{ADJ}	Guaranteed by design	0		0.4 × V _{LCD}	V
LCD Bias Resistor	R _{LCD}			20		kΩ
LCD Adjust Resistor	R _{LADJ}	LRA4:LRA0 = 0		40		kΩ
LCD Segment Voltage	V _{SEGxx}	Segment is driven at V _{LCD} ; V _{LCD} = 3V, I _{SEGxx} = -3μA, guaranteed by design		V _{LCD} - 0.02	V _{LCD}	V
		Segment is driven at V _{LCD1} ; V _{LCD1} = 2V, I _{SEGxx} = -3μA, guaranteed by design		V _{LCD1} - 0.02	V _{LCD1}	V
		Segment is driven at V _{LCD2} ; V _{LCD2} = 1V, I _{SEGxx} = -3μA, guaranteed by design		V _{LCD2} - 0.02	V _{LCD2}	V
		Segment is driven at V _{ADJ} ; V _{ADJ} = 0V, I _{SEGxx} = +3μA, guaranteed by design		V _{ADJ}	0.1	V
CLOCK SOURCE						
External Crystal Frequency	f _{HFXIN}		1		8	MHz
REAL-TIME CLOCK						
RTC Input Frequency	f _{32KIN}	32kHz watch crystal		32.768		kHz
JTAG/FLASH PROGRAMMING						
JTAG Clock Rate	f _{TCK}				sysclk / 8	
Flash Erase Time		Mass erase		904		ms
		Page erase		313		
Flash Programming Time				17		μs
Write/Erase Cycles				1,000,000		Cycles
Data Retention				20		Years

Note 1: Specifications to -40°C are guaranteed by design and not production tested. All typical values are guaranteed by design characterization and are not production tested.

Note 2: Tested with T_A = +25°C, DV_{DD} = 3.3V, and all peripherals inactive except for port pins.

Note 3: These numbers are guaranteed by design and are not tested.

Note 4: Can be calculated as (f_{HFXIN} / 6).

Note 5: Can be calculated as 6 / (f_{HFXIN} × C_{IN}).

Note 6: Can be calculated as 12 / (f_{HFXIN} × C_{IN}).

Note 7: Assumes that no external components are connected to V_{LCD}, V_{LCD1}, V_{LCD2}, or V_{ADJ}.

High-Precision ADC Mixed-Signal Microcontroller

Typical Operating Characteristics

($T_A = +25^\circ\text{C}$, unless otherwise noted.)

MAXQ3120

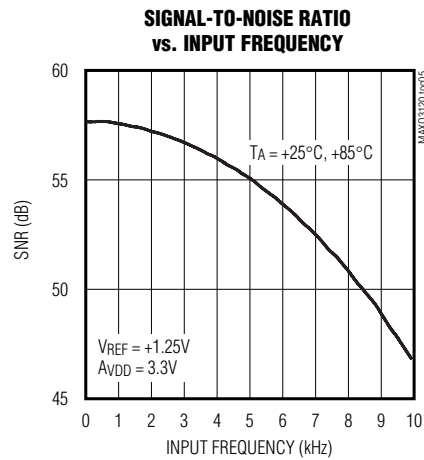
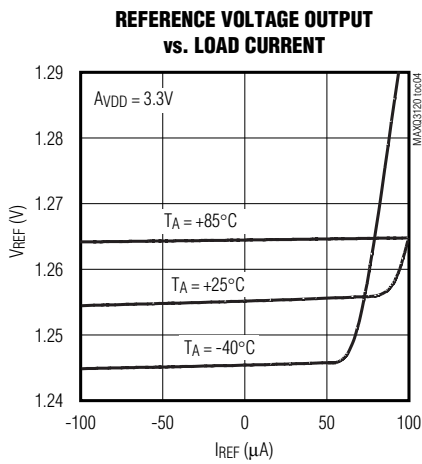
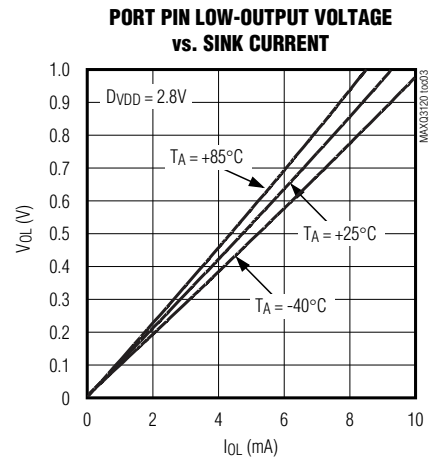
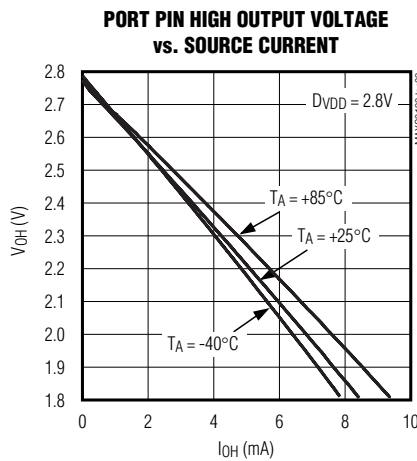
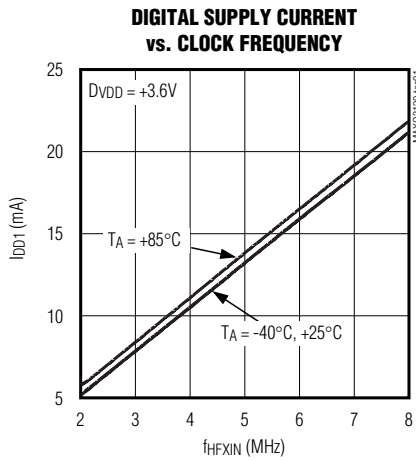

High-Precision ADC Mixed-Signal Microcontroller

Pin Description

PIN	NAME	FUNCTION
22, 38, 60, 74	DVDD	Digital Supply Voltage (+3.3V)
19, 37, 43, 59, 75	DGND	Digital Ground
44	AVDD	Analog Supply Voltage
52	AGND	Analog Ground
12	V _{LCD}	LCD Bias-Control Voltage. Highest LCD drive voltage used in all bias modes. This pin must be connected to an external supply when using the LCD display controller.
13	V _{LCD1}	LCD Bias, Voltage 1. Next highest LCD drive voltage, used in 1/2 and 1/3 LCD bias modes. An internal resistor-divider sets the voltage at this pin. External resistors and capacitors can be used to change LCD voltage or drive capability at this pin. This pin must be shunted externally to V _{LCD2} when using 1/2 bias mode.
14	V _{LCD2}	LCD Bias, Voltage 2. Third highest LCD drive voltage, used in 1/3 LCD bias mode only. An internal resistor-divider sets the voltage at this pin. External resistors and capacitors can be used to change LCD voltage or drive capability at this pin. This pin must be shunted externally to V _{LCD1} when using 1/2 bias mode.
15	V _{ADJ}	LCD Adjustment Voltage. Lowest LCD drive voltage, used in all bias modes. Connect to DGND through an external resistor to provide external control of the LCD contrast. Leave disconnected for internal contrast adjustment.
63	RESET	Digital, Active-Low, Reset Input/Output. The CPU is held in reset when this is low and begins executing from the reset vector when released. The pin includes a pullup current source and should be driven by an open-drain, external source capable of sinking in excess of 2mA. This pin is driven low as an output when an internal reset condition occurs.
20	HFXIN	High-Frequency Crystal Input. Connect an external crystal between HFXIN and HFXOUT to generate the high-frequency system clock. HFXIN and HFXOUT contain integral 16pF load capacitors, so no external capacitor is required.
21	HFXOUT	High-Frequency Crystal Output. Connect an external crystal between HFXIN and HFXOUT to generate the high-frequency system clock. HFXIN and HFXOUT contain integral 16pF load capacitors, so no external capacitor is required.
53	V _{BAT}	Digital Battery-Backup Supply. This supply provides an optional battery backup for the RTC when DVDD power is removed. If this supply is not provided, all functions of the device operate as normal, but the RTC is cleared upon power-on reset (POR).
61	32KIN	32kHz Crystal Input. Connect an external, 32kHz watch crystal between 32KIN and 32KOUT to generate the 32kHz system clock. This clock is required for the RTC to operate.
62	32KOUT	32kHz Crystal Output. Connect an external, 32kHz watch crystal between 32KIN and 32KOUT to generate the 32kHz system clock. This clock is required for the RTC to operate.
51	V _{REF}	Voltage Reference Input/Output. Bias voltage (+1.25V) for the ADCs. An external reference voltage can be connected to this pin when extremely high accuracy is required.
45	AN0-	Negative Input for Sigma-Delta ADC Channel 0
46	AN0+	Positive Input for Sigma-Delta ADC Channel 0
47	AN1-	Negative Input for Sigma-Delta ADC Channel 1
48	AN1+	Positive Input for Sigma-Delta ADC Channel 1

High-Precision ADC Mixed-Signal Microcontroller

Pin Description (continued)

MAXQ3120

PIN	NAME	FUNCTION			
64–71	P0.0–P0.7/ SQW, RXD0, TXD0, INT0–INT2/ T2A, T2B/ TOG, T0, T1	General-Purpose, Digital, I/O, Type-D Port; External Edge-Selectable Interrupt. These port pins function as bidirectional I/O pins only. All port pins default to input mode with weak pullups enabled after a reset. Port pins P0.3, P0.4, and P0.5 can be configured as external interrupt inputs. All alternate functions must be enabled from software.			
		PIN	PORT	ALTERNATE FUNCTIONS	
		64	P0.0	RTC Square-Wave Output	—
		65	P0.1	Serial Port 0 Receive	—
		66	P0.2	Serial Port 0 Transmit	—
		67	P0.3	Timer 0 Gate Input	INT0
		68	P0.4	Timer 0 Input	INT1
		69	P0.5	Timer 1 Input/Output	INT2
		70	P0.6	Timer 2 Input/Output A (T2P)	—
71	P0.7	Timer 2 Input/Output B (T2PB)	—		
76–80, 1, 2, 3	P1.0–P1.7/ SEG19– SEG12	General-Purpose, 8-Bit, Digital, I/O, Type-C Port; LCD Segment-Driver Output. These port pins function as both bidirectional I/O pins and LCD segment-drive outputs. All port pins default to input mode with weak pullups enabled after a reset. Setting the LCD enable (PCF _x) bit for a group of four port pins enables the LCD function and disables the general-purpose I/O function on all pins in that group.			
		PIN	PORT	LCD SEGMENT	LCD ENABLE
		76	P1.0	SEG19	PCF1
		77	P1.1	SEG18	
		78	P1.2	SEG17	
		79	P1.3	SEG16	
		80	P1.4	SEG15	PCF0
		1	P1.5	SEG14	
		2	P1.6	SEG13	
3	P1.7	SEG12			
28–34, 39	P2.0–P2.7/ SEG20– SEG27	General-Purpose, 8-Bit, Digital, I/O, Type-C Port; LCD Segment-Driver Output. These port pins function as both bidirectional I/O pins and LCD segment-drive outputs. All port pins default to input mode with weak pullups enabled after a reset. Setting the LCD enable (PCF _x) bit for a group of four port pins enables the LCD function and disables the general-purpose I/O function on all pins in that group.			
		PIN	PORT	LCD SEGMENT	LCD ENABLE
		28	P2.0	SEG20	PCF2
		29	P2.1	SEG21	
		30	P2.2	SEG22	
		31	P2.3	SEG23	
		32	P2.4	SEG24	PCF3
		33	P2.5	SEG25	
		34	P2.6	SEG26	
39	P2.7	SEG27			

High-Precision ADC Mixed-Signal Microcontroller

Pin Description (continued)

PIN	NAME	FUNCTION		
40, 41, 42, 54–58	P3.0–P3.7/ TDO, TDI, TMS, TCK, TXDI, RXDI	General-Purpose, 8-Bit, Digital, I/O, Type-C Port. These port pins function as bidirectional I/O pins only. All port pins default to input mode with weak pullups enabled after a reset. JTAG functions are enabled by default following reset; all other alternate functions must be enabled from software.		
		PIN	PORT	ALTERNATE FUNCTION
		40	P3.0	TDO–JTAG Data Out
		41	P3.1	TDI–JTAG Data In
		42	P3.2	TMS–JTAG Mode Select
		54	P3.3	TCK–JTAG Clock
		55	P3.4	—
		56	P3.5	—
		57	P3.6	Serial Port 1 Transmit
58	P3.7	Serial Port 1 Receive		
23	SEG0	LCD Segment 0 Driver. Dedicated LCD drive output.		
18	SEG1	LCD Segment 1 Driver. Dedicated LCD drive output.		
17	SEG2	LCD Segment 2 Driver. Dedicated LCD drive output.		
16	SEG3	LCD Segment 3 Driver. Dedicated LCD drive output.		
11	SEG4	LCD Segment 4 Driver. Dedicated LCD drive output.		
10	SEG5	LCD Segment 5 Driver. Dedicated LCD drive output.		
9	SEG6	LCD Segment 6 Driver. Dedicated LCD drive output.		
8	SEG7	LCD Segment 7 Driver. Dedicated LCD drive output.		
7	SEG8	LCD Segment 8 Driver. Dedicated LCD drive output.		
6	SEG9	LCD Segment 9 Driver. Dedicated LCD drive output.		
5	SEG10	LCD Segment 10 Driver. Dedicated LCD drive output.		
4	SEG11	LCD Segment 11 Driver. Dedicated LCD drive output.		
27	COM0	LCD Common 0 Driver. Dedicated LCD common-voltage output.		
26	COM1	LCD Common 1 Driver. Dedicated LCD common-voltage output.		
25	COM2	LCD Common 2 Driver. Dedicated LCD common-voltage output.		
24	COM3	LCD Common 3 Driver. Dedicated LCD common-voltage output.		
35, 36, 49, 50, 72, 73	N.C.	No Connection		

High-Precision ADC Mixed-Signal Microcontroller

Functional Diagram

MAXQ3120

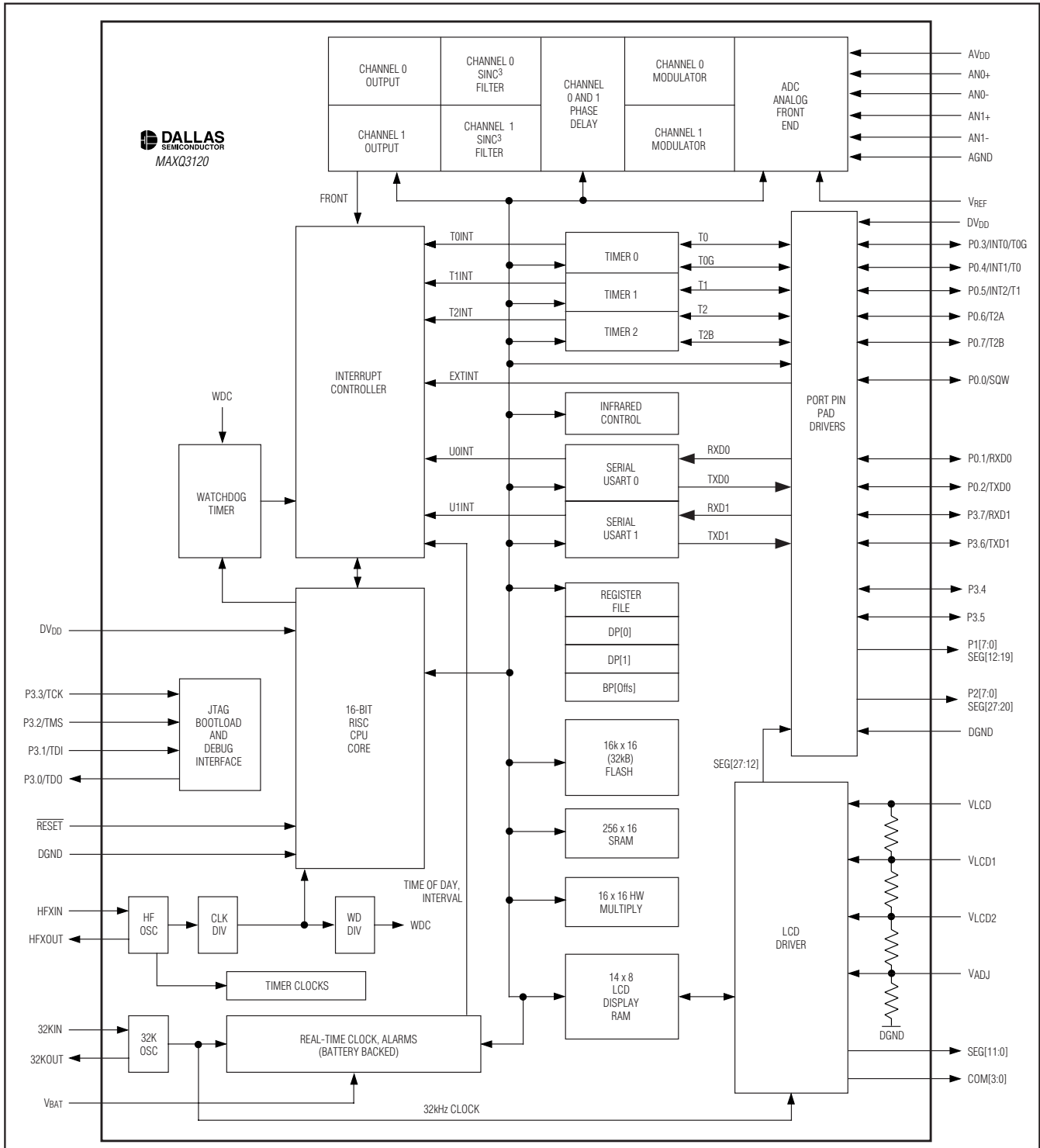

High-Precision ADC Mixed-Signal Microcontroller

Detailed Description

The following is an introduction to the primary features of the microcontroller. More detailed descriptions of the device features can be found in the data sheets, errata sheets, and user's guides described later in the *Additional Documentation* section.

MAXQ Core Architecture

The MAXQ3120 is a low-cost, high-performance, CMOS, 16-bit RISC microcontroller with flash memory and an integrated 112-segment LCD controller. It is structured on a highly advanced, accumulator-based, 16-bit RISC architecture. Fetch and execution operations are completed in one cycle without pipelining, because the instruction contains both the op code and data. The result is a streamlined 8 million instructions-per-second (MIPS) microcontroller.

The highly efficient core is supported by a 16-level hardware stack, enabling fast subroutine calling and task switching. Data can be quickly and efficiently manipulated with three internal data pointers. Multiple data pointers allow more than one function to access data memory without having to save and restore data pointers each time. The data pointers can automatically increment or decrement following an operation, eliminating the need for software intervention. As a result, the application speed is greatly increased.

Instruction Set

The instruction set is composed of fixed-length, 16-bit instructions that operate on registers and memory locations. The instruction set is highly orthogonal, allowing arithmetic and logical operations to use any register along with the accumulator. System registers control functionality common to all MAXQ microcontrollers, while peripheral registers control peripherals and functions specific to the MAXQ3120. All registers are subdivided into register modules. The family architecture is modular, so that new devices and modules can reuse code developed for existing products.

The architecture is transport-triggered. This means that writes or reads from certain register locations can also cause side effects to occur. These side effects form the basis for the higher-level op codes defined by the assembler, such as ADDC, OR, JUMP, etc. The op codes are actually implemented as MOVE instructions between certain system register locations, while the assembler handles the encoding, which need not be a concern to the programmer.

The 16-bit instruction word is designed for efficient execution. Bit 15 indicates the format for the source field of

the instruction. Bits 0 to 7 of the instruction represent the source for the transfer. Depending on the value of the format field, this can either be an 8-bit immediate value or a source register. If this field represents a register, the lower four bits contain the module specifier and the upper four bits contain the register index in that module.

Bits 8 to 14 represent the destination for the transfer. This value always represents a destination register, with the lower four bits containing the module specifier and the upper three bits containing the register subindex within that module.

The following types of instructions require the use of the prefix register, PFX, to supply additional data.

- Loading a 16-bit immediate value (with a nonzero high byte) into any register
- Branching to a 16-bit absolute destination address (LJMP or LCALL)
- Selecting one of the upper 8 registers in a system register module as a destination
- Selecting one of the upper 16 registers in a peripheral register module as a source
- Selecting one of the upper 24 registers in a peripheral register module as a destination

For any of these instruction types, the prefix register is used to supply the additional immediate value bits, source bits, and destination bits as needed. This prefix register write is inserted automatically by the assembler and requires only one additional execution cycle for any or all of these conditions.

Memory Organization

The device incorporates several memory areas:

- 2kWords utility ROM
- 16kWords of flash memory for program storage
- 256 words of SRAM for storage of temporary variables
- 16-level, 16-bit-wide stack memory for storage of program return addresses and general-purpose use

The memory is arranged by default in a Harvard architecture, with separate address spaces for program and data memory. The configuration of program and data space depends on the current execution location.

- When executing code from flash memory, the SRAM and utility ROM are accessible in data space.
- When executing code from SRAM, the flash memory and utility ROM are accessible in data space.
- When executing code from the utility ROM, the flash memory and SRAM are accessible in data space.

High-Precision ADC Mixed-Signal Microcontroller

Refer to the user's guide supplement for this device for more details.

In all cases, whichever memory segment is currently being executed from cannot be accessed in data space. To allow the use of lookup tables and similar constructs in the flash memory, the utility ROM contains a set of lookup and block copy routines (refer to the user's guide supplement for this device for more details).

The incorporation of flash memory allows the device to be reprogrammed, eliminating the expense of throwing away one-time programmable devices during development and field upgrades. Flash memory can be password protected with a 16-word key, denying access to program memory by unauthorized individuals.

Stack Memory

A 16-bit-wide internal stack provides storage for program return addresses and general-purpose use. The stack is used automatically by the processor when the CALL, RET, and RETI instructions are executed and interrupts serviced. The stack can also be used explic-

itly to store and retrieve data by using the PUSH, POP, and POPI instructions.

On reset, the stack pointer, SP, initializes to the top of the stack (0Fh). The CALL, PUSH, and interrupt-vectoring operations increment SP, then store a value at the stack location pointed to by SP. The RET, RETI, POP, and POPI operations retrieve the value at the stack location pointed to by SP, and then decrement SP.

Utility ROM

The utility ROM is a 2kWord block of internal ROM memory that defaults to a starting address of 8000h. The utility ROM consists of subroutines that can be called from application software. These include:

- In-system programming (bootloader) over the JTAG interface
- In-circuit debug routines
- Test routines (internal memory tests, memory loader, etc.)
- User-callable routines for in-application flash programming and code space table lookup

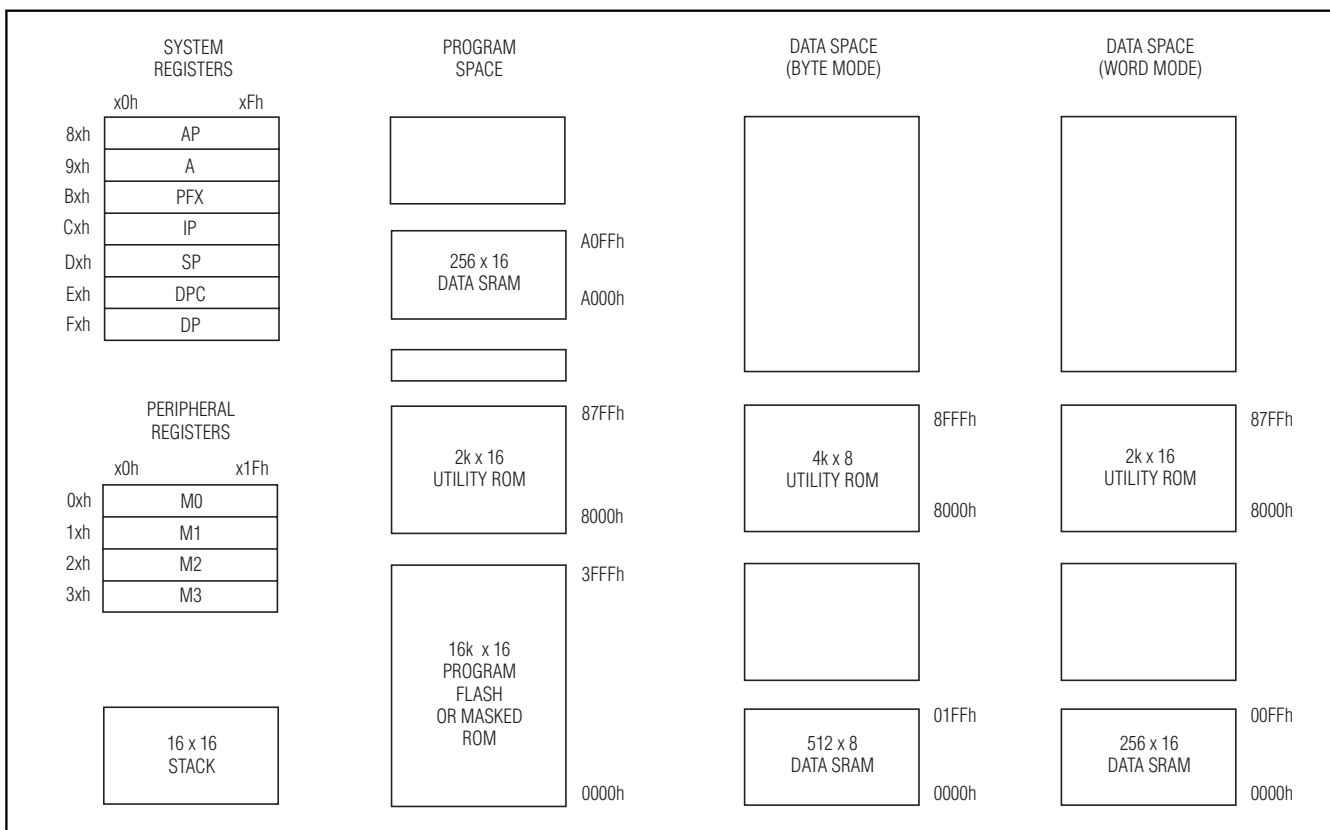

Figure 1. Memory Map

High-Precision ADC Mixed-Signal Microcontroller

Following any reset, execution begins in the utility ROM. The ROM software determines whether the program execution should immediately jump to the start of user-application code (located at address 0000h), or to one of the special routines mentioned. Routines within the utility ROM are user-accessible and can be called as subroutines by the application software. More information on the utility ROM contents is contained in the user's guide supplement for this device.

Some applications require protection against unauthorized viewing of program code memory. For these applications, access to in-system programming, in-application programming, or in-circuit debugging functions is prohibited until a password has been supplied.

A single password-lock (PWL) bit is implemented in the SC register. When the PWL is set to one (power-on reset default), the password is required to access the utility ROM, including in-circuit debug and in-system programming routines that allow reading or writing of internal memory. When PWL is cleared to zero, these utilities are fully accessible without the password. The password is automatically set to all ones following a mass erase.

Programming

The flash memory of the microcontroller can be programmed by two different methods: in-system programming and in-application programming. Both methods afford great flexibility in system design as well as reduce the life-cycle cost of the embedded system. These features can be password protected to prevent unauthorized access to code memory.

In-System Programming

An internal bootstrap loader allows the device to be reloaded over a simple JTAG interface. As a result, system software can be upgraded in-system, eliminating the need for a costly hardware retrofit when software updates are required. Remote software uploads are possible that enable physically inaccessible applications to be frequently updated. The interface hardware can be a JTAG connection to another microcontroller, or a connection to a PC serial port using a serial-to-JTAG converter such as the MAXQJTAG-001, available from Maxim Integrated Products/Dallas Semiconductor. If in-system programmability is not required, a commercial gang programmer can be used for mass programming.

Activating the JTAG interface and loading the test access port (TAP) with the system programming instruction invokes the bootloader. Setting the SPE bit to 1 during reset through the JTAG interface executes the bootloader-mode program that resides in the utility ROM. When programming is complete, the bootloader can clear the SPE bit and reset the device, allowing the device to bypass the utility ROM and begin execution of the application software.

The following bootloader functions are supported:

- Load
- Dump
- CRC
- Verify
- Erase

In-Application Programming

The in-application programming feature allows the microcontroller to modify its own flash program memory while simultaneously executing its application software. This allows on-the-fly software updates in mission-critical applications that cannot afford downtime. Alternatively, it allows the application to develop custom loader software that can operate under the control of the application software. The utility ROM contains user-accessible flash programming functions that erase and program flash memory. These functions are described in detail in the user's guide supplement for this device.

Register Set

Most functions of the device are controlled by sets of registers. These registers provide a working space for memory operations as well as configuring and addressing peripheral registers on the device. Registers are divided into two major types: system registers and peripheral registers. The common register set, also known as the system registers, includes the ALU, accumulator registers, data pointers, interrupt vectors and control, and stack pointer. The peripheral registers define additional functionality that may be included by different products based on the MAXQ architecture. This functionality is broken up into discrete modules so that only the features required for a given product need to be included. Tables 1 and 4 show the MAXQ3120 register set.

High-Precision ADC Mixed-Signal Microcontroller

MAXQ3120

Table 1. System Register Map

REGISTER INDEX	AP (8h)	A (9h)	PFX (Bh)	IP (Ch)	SP (Dh)	DPC (Eh)	DP (Fh)
0xh	AP	A[0]	PFX	IP	—	—	—
1xh	APC	A[1]	—	—	SP	—	—
2xh	—	A[2]	—	—	IV	—	—
3xh	—	A[3]	—	—	—	Offs	DP[0]
4xh	PSF	A[4]	—	—	—	DPC	—
5xh	IC	A[5]	—	—	—	GR	—
6xh	IMR	A[6]	—	—	LC[0]	GRL	—
7xh	—	A[7]	—	—	LC[1]	BP	DP[1]
8xh	SC	A[8]	—	—	—	GRS	—
9xh	—	A[9]	—	—	—	GRH	—
Axh	—	A[10]	—	—	—	GRXL	—
Bxh	<i>IIR</i>	A[11]	—	—	—	BP[offs]	—
Cxh	—	A[12]	—	—	—	—	—
Dxh	—	A[13]	—	—	—	—	—
Exh	CKCN	A[14]	—	—	—	—	—
Fxh	WDCN	A[15]	—	—	—	—	—

Note: Names that appear in italics indicate that all bits of a register are read-only. Names that appear in bold indicate that a register is 16 bits wide. Registers in module AP are bit addressable.

High-Precision ADC Mixed-Signal Microcontroller

Table 2. System Register Bit Functions

REGISTER	REGISTER BIT															
	15	14	13	12	11	10	9	8	7	6	5	4	3	2	1	0
AP									—	—	—	—	AP (4 bits)			
APC									CLR	IDS	—	—	—	MOD2	MOD1	MOD0
PSF									Z	S	—	GPF1	GPF0	OV	C	E
IC									—	—	CGDS	—	—	—	INS	IGE
IMR									IMS	—	—	—	IM3	IM2	IM1	IM0
SC									TAP	—	—	—	—	ROD	PWL	—
IIR									IIS	—	—	—	II3	II2	II1	II0
CKCN									—	—	—	STOP	SWB	PMME	CD1	CD0
WDCN									POR	EWDI	WD1	WD0	WDIF	WTRF	EWT	RWT
A[0..15]	A[n] (16 bits)															
PFX	PFX (16 bits)															
IP	IP (16 bits)															
SP	—	—	—	—	—	—	—	—	—	—	—	—	—	SP (4 bits)		
IV	IV (16 bits)															
LC[0]	LC[0] (16 bits)															
LC[1]	LC[1] (16 bits)															
Offs													Offs (8 bits)			
DPC	—	—	—	—	—	—	—	—	—	—	—	WBS2	WBS1	WBS0	SDPS1	SDPS0
GR	GR (16 bits)															
GRL									GR.7	GR.6	GR.5	GR.4	GR.3	GR.2	GR.1	GR.0
BP	BP (16 bits)															
GRS	GR.7	GR.6	GR.5	GR.4	GR.3	GR.2	GR.1	GR.0	GR.15	GR.14	GR.13	GR.12	GR.11	GR.10	GR.9	GR.8
GRH									GR.15	GR.14	GR.13	GR.12	GR.11	GR.10	GR.9	GR.8
GRXL	GR.7	GR.7	GR.7	GR.7	GR.7	GR.7	GR.7	GR.7	GR.7	GR.6	GR.5	GR.4	GR.3	GR.2	GR.1	GR.0
BP[offs]	BP[offs] (16 bits)															
DP[0]	DP[0] (16 bits)															
DP[1]	DP[1] (16 bits)															

High-Precision ADC Mixed-Signal Microcontroller

MAXQ3120

Table 3. System Register Reset Values

REGISTER	REGISTER BIT															
	15	14	13	12	11	10	9	8	7	6	5	4	3	2	1	0
AP									0	0	0	0	0	0	0	0
APC									0	0	0	0	0	0	0	0
PSF									<i>i</i>	<i>i</i>	0	0	0	0	0	0
IC									0	0	0	0	0	0	0	0
IMR									0	0	0	0	0	0	0	0
SC									1	0	<i>i</i>	<i>i</i>	<i>i</i>	0	0	0
IIR									0	0	0	0	0	0	0	0
CKCN									1	0	0	0	0	0	0	0
WDCN									<i>s</i>	<i>s</i>	0	0	0	<i>s</i>	<i>s</i>	0
A[0..15]	<i>i</i>	<i>i</i>	<i>i</i>	<i>i</i>	<i>i</i>	<i>i</i>	<i>i</i>	<i>i</i>	<i>i</i>	<i>i</i>	<i>i</i>	<i>i</i>	<i>i</i>	<i>i</i>	<i>i</i>	<i>i</i>
PFX	0	0	0	0	0	0	0	0	0	0	0	0	0	0	0	0
IP	1	0	0	0	0	0	0	0	0	0	0	0	0	0	0	0
SP	0	0	0	0	0	0	0	0	0	0	0	0	1	1	1	1
IV	0	0	0	0	0	0	0	0	0	0	0	0	0	0	0	0
LC[0]	0	0	0	0	0	0	0	0	0	0	0	0	0	0	0	0
LC[1]	0	0	0	0	0	0	0	0	0	0	0	0	0	0	0	0
Offs									0	0	0	0	0	0	0	0
DPC	0	0	0	0	0	0	0	0	0	0	0	1	1	1	0	0
GR	0	0	0	0	0	0	0	0	0	0	0	0	0	0	0	0
GRL									0	0	0	0	0	0	0	0
BP	0	0	0	0	0	0	0	0	0	0	0	0	0	0	0	0
GRS	0	0	0	0	0	0	0	0	0	0	0	0	0	0	0	0
GRH									0	0	0	0	0	0	0	0
GRXL	0	0	0	0	0	0	0	0	0	0	0	0	0	0	0	0
BP[offs]	0	0	0	0	0	0	0	0	0	0	0	0	0	0	0	0
DP[0]	0	0	0	0	0	0	0	0	0	0	0	0	0	0	0	0
DP[1]	0	0	0	0	0	0	0	0	0	0	0	0	0	0	0	0

Note: Bits marked with an “i” have an indeterminate value upon reset. Bits marked with an “s” have special behavior upon reset. Refer to the user’s guide supplement for this device for more details.

High-Precision ADC Mixed-Signal Microcontroller

Table 4. Peripheral Register Map

REGISTER INDEX	M0 (0h)	M1 (1h)	M2 (2h)	M3 (3h)	M4 (4h)	M5 (5h)
00h	PO0	T0CN	T1CN	MCNT	—	—
01h	PO1	T0L	T1L	MA	—	—
02h	PO2	T0H	T1H	MB	—	—
03h	PO3	SCON0	T2CNA	MC2	—	—
04h	—	SBUF0	T2H	MC1	—	—
05h	—	SCON1	T2RH	MC0	—	—
06h	EIF0	SBUF1	T2CH	MC1R	—	—
07h	EIE0	—	IRCN	MC0R	—	—
08h	<i>PI0</i>	—	T1CL	ADCN	—	—
09h	<i>PI1</i>	SMD0	T1CH	PHC	—	—
0Ah	<i>PI2</i>	PR0	T1MD	AD0	—	—
0Bh	<i>PI3</i>	SMD1	T2CNB	AD1	—	—
0Ch	EIES0	PR1	T2V	ATRM	—	—
0Dh	—	—	T2R	LCRA	—	—
0Eh	—	—	T2C	LCFG	—	—
0Fh	—	—	T2CFG	—	—	—
10h	PD0	—	—	LCD0	—	—
11h	PD1	—	—	LCD1	—	—
12h	PD2	—	—	LCD2	—	—
13h	PD3	—	—	LCD3	—	—
14h	—	—	—	LCD4	—	—
15h	—	—	—	LCD5	—	—
16h	—	—	—	LCD6	—	—
17h	—	—	—	LCD7	—	—
18h	RTRM	—	—	LCD8	—	—
19h	RCNT	—	—	LCD9	—	—
1Ah	RTSS	—	—	LCD10	—	—
1Bh	RTSH	ICDF	—	LCD11	—	—
1Ch	RTSL	—	—	LCD12	—	—
1Dh	RSSA	—	—	LCD13	—	—
1Eh	RASH	—	—	—	—	—
1Fh	RASL	—	—	—	—	—

Note: Names that appear in italics indicate that all bits of a register are read-only. Names that appear in bold indicate that a register is 16 bits wide. Registers in module AP are bit addressable.

High-Precision ADC Mixed-Signal Microcontroller

MAXQ3120

Table 5. Peripheral Register Bit Functions

REGISTER	REGISTER BIT															
	15	14	13	12	11	10	9	8	7	6	5	4	3	2	1	0
PO0									PO0 (8 bits)							
PO1									PO1 (8 bits)							
PO2									PO2 (8 bits)							
PO3									PO3 (8 bits)							
EIF0									—	—	—	—	—	IE2	IE1	IE0
EIE0									—	—	—	—	—	EX2	EX1	EX0
PI0									PI0 (8 bits)							
PI1									PI1 (8 bits)							
PI2									PI2 (8 bits)							
PI3									PI3 (8 bits)							
EIES0									—	—	—	—	—	IT2	IT1	IT0
PD0									PD0 (8 bits)							
PD1									PD1 (8 bits)							
PD2									PD2 (8 bits)							
PD3									PD3 (8 bits)							
RTRM									—	—	TSGN	TRM (5 bits)				
RCNT	WE	—	—	—	—	—	FT	SQE	ALSF	ALDF	RDYE	RDY	BUSY	ASE	ADE	RTCE
RTSH	RTSH (16 bits)															
RTSL	RTSL (16 bits)															
RSSA	—	—	—	—	—	RSSA (11 bits)										
RASH									—	—	—	—	RASH (4 bits)			
RASL	RASL (16 bits)															
TOCN									ET0	TOM	TF0	TR0	GATE	C/T	M1	M0
TOL									TOL (8 bits)							
TOH									TOH (8 bits)							
SCON0									SM0/FE	SM1	SM2	REN	TB8	RB8	TI	RI
SBUF0									SBUF0 (8 bits)							
SCON1									SM0/FE	SM1	SM2	REN	TB8	RB8	TI	RI
SBUF1									SBUF1 (8 bits)							
SMD0									EPWM	OFS	—	—	—	ESI	SMOD	FEDE
PR0	PR0 (16 bits)															
SMD1									—	—	—	—	—	ESI	SMOD	FEDE
PR1	PR1 (16 bits)															

High-Precision ADC Mixed-Signal Microcontroller

Table 5. Peripheral Register Bit Functions (continued)

REGISTER	REGISTER BIT															
	15	14	13	12	11	10	9	8	7	6	5	4	3	2	1	0
ICDF									—	—	—	—	PSS1	PSS0	SPE	—
T1CN									TF1	EXF1	T1OE	DCEN	EXEN1	TR1	C/T1	CPRL1
T1L									T1L (8 bits)							
T1H									T1H (8 bits)							
T2CNA									ET2	T2OE0	T2POL0	TR2L	TR2	CPRL2	SS2	G2EN
T2H									T2V[15:8] (8 bits)							
T2RH									T2R[15:8] (8 bits)							
T2CH									T2C[15:8] (8 bits)							
IRCN									—	—	—	—	—	IREN	IRTX	IRBB
T1CL									T1CL (8 bits)							
T1CH									T1CH (8 bits)							
T1MD									—	—	—	—	—	—	ET1	T1M
T2CNB									ET2L	T2OE1	T2POL1	—	TF2	TCC2	TF2L	TC2L
T2V									T2V (16 bits)							
T2R									T2R (16 bits)							
T2C									T2C (16 bits)							
T2CFG									T2CI	DIV2	DIV1	DIV0	T2MD	CCF1	CCF0	C/T2
MCNT									OF	MCW	CLD	SQU	OPCS	MSUB	MMAC	SUS
MA									MA (16 bits)							
MB									MB (16 bits)							
MC2	—	—	—	—	—	—	—	—	MC2 (8 bits)							
MC1									MC1 (16 bits)							
MC0									MC0 (16 bits)							
MC1R									MC1R (16 bits)							
MC0R									MC0R (16 bits)							
ADCN	G3	G2	G1	G0	—	APD2	APD1	APD0	UFF	EDBI	FLU1	FLU0	FOV1	FOV0	ABF1	ABF0
PHC	ZPS	—	—	—	—	—	—	—	PH (9 bits)							
AD0									AD0 (16 bits)							
AD1									AD1 (16 bits)							
ATRM									—	—	—	ABGT (5 bits)				
LCRA	—	—	—	DUTY1	DUTY0	FRM3	FRM2	FRM1	FRM0	LCCS	LRIG	—	LRA3	LRA2	LRA1	LRA0
LCFG									PCF3	PCF2	PCF1	PCF0	—	—	OPM	DPE
LCD[0..13]									LCD[n] (8 bits)							

High-Precision ADC Mixed-Signal Microcontroller

MAXQ3120

Table 6. Peripheral Register Bit Reset Values

REGISTER	REGISTER BIT															
	15	14	13	12	11	10	9	8	7	6	5	4	3	2	1	0
PO0									1	1	1	1	1	1	1	1
PO1									1	1	1	1	1	1	1	1
PO2									1	1	1	1	1	1	1	1
PO3									1	1	1	1	1	1	1	1
EIF0									0	0	0	0	0	0	0	0
EIE0									0	0	0	0	0	0	0	0
PI0									s	s	s	s	s	s	s	s
PI1									s	s	s	s	s	s	s	s
PI2									s	s	s	s	s	s	s	s
PI3									s	s	s	s	s	s	s	s
EIES0									0	0	0	0	0	0	0	0
PD0									0	0	0	0	0	0	0	0
PD1									0	0	0	0	0	0	0	0
PD2									0	0	0	0	0	0	0	0
PD3									0	0	0	0	0	0	0	0
RTRM									0	0	s	s	s	s	s	s
RCNT	0	0	0	0	0	0	0	0	0	0	0	0	1	0	0	s
RTSS									s	s	s	s	s	s	s	s
RTSH	s	s	s	s	s	s	s	s	s	s	s	s	s	s	s	s
RTSL	s	s	s	s	s	s	s	s	s	s	s	s	s	s	s	s
RSSA	0	0	0	0	0	s	s	s	s	s	s	s	s	s	s	s
RASH									0	0	0	0	s	s	s	s
RASL	s	s	s	s	s	s	s	s	s	s	s	s	s	s	s	s
T0CN									0	0	0	0	0	0	0	0
T0L									0	0	0	0	0	0	0	0
T0H									0	0	0	0	0	0	0	0
SCON0									0	0	0	0	0	0	0	0
SBUF0									0	0	0	0	0	0	0	0
SCON1									0	0	0	0	0	0	0	0
SBUF1									0	0	0	0	0	0	0	0
SMD0									0	0	0	0	0	0	0	0
PR0	0	0	0	0	0	0	0	0	0	0	0	0	0	0	0	0
SMD1									0	0	0	0	0	0	0	0
PR1	0	0	0	0	0	0	0	0	0	0	0	0	0	0	0	0
ICDF									0	0	0	0	0	0	0	0
T1CN									0	0	0	0	0	0	0	0
T1L									0	0	0	0	0	0	0	0

High-Precision ADC Mixed-Signal Microcontroller

Table 6. Peripheral Register Bit Reset Values (continued)

REGISTER	REGISTER BIT															
	15	14	13	12	11	10	9	8	7	6	5	4	3	2	1	0
T1H									0	0	0	0	0	0	0	0
T2CNA									0	0	0	0	0	0	0	0
T2H									0	0	0	0	0	0	0	0
T2RH									0	0	0	0	0	0	0	0
T2CH									0	0	0	0	0	0	0	0
IRC�									0	0	0	0	0	0	0	0
T1CL									0	0	0	0	0	0	0	0
T1CH									0	0	0	0	0	0	0	0
T1MD									0	0	0	0	0	0	0	0
T2CNB									0	0	0	0	0	0	0	0
T2V	0	0	0	0	0	0	0	0	0	0	0	0	0	0	0	0
T2R	0	0	0	0	0	0	0	0	0	0	0	0	0	0	0	0
T2C	0	0	0	0	0	0	0	0	0	0	0	0	0	0	0	0
T2CFG									0	0	0	0	0	0	0	0
MCNT									0	0	0	0	0	0	0	0
MA	0	0	0	0	0	0	0	0	0	0	0	0	0	0	0	0
MB	0	0	0	0	0	0	0	0	0	0	0	0	0	0	0	0
MC2	0	0	0	0	0	0	0	0	0	0	0	0	0	0	0	0
MC1	0	0	0	0	0	0	0	0	0	0	0	0	0	0	0	0
MC0	0	0	0	0	0	0	0	0	0	0	0	0	0	0	0	0
MC1R	0	0	0	0	0	0	0	0	0	0	0	0	0	0	0	0
MC0R	0	0	0	0	0	0	0	0	0	0	0	0	0	0	0	0
ADCN	s	s	s	s	0	s	s	s	0	0	0	0	0	0	0	0
PHC	s	0	0	0	0	0	0	s	s	s	s	s	s	s	s	s
AD0	i	i	i	i	i	i	i	i	i	i	i	i	i	i	i	i
AD1	i	i	i	i	i	i	i	i	i	i	i	i	i	i	i	i
ATRM									0	0	0	s	s	s	s	s
LCRA	0	0	0	0	0	0	0	0	0	0	0	0	0	0	0	0
LCFG									0	0	0	0	0	0	0	0
LCD[0..13]									0	0	0	0	0	0	0	0

Note: Bits marked with an "i" have an indeterminate value upon reset. Bits marked with an "s" have special behavior upon reset. Refer to the user's guide supplement for this device for more details.

High-Precision ADC Mixed-Signal Microcontroller

System Timing

The MAXQ3120 generates its internal system clock from an external high-frequency crystal. Because the MAXQ3120 includes internal capacitors for this purpose, no external capacitors are required to use the high-frequency crystal. The MAXQ3120 should not be driven directly by an external clock source.

A crystal warmup counter enhances operational reliability. Each time the external crystal oscillation must restart, such as after exiting stop mode, the device initiates a crystal warmup period of 65,536 oscillations. This allows time for the crystal amplitude and frequency to stabilize before using it as a clock source.

Power Management

Advanced power-management features minimize power consumption by dynamically matching the processing speed of the device to the required performance level. This means device operation can be slowed and power consumption minimized during periods of reduced

activity. When more processing power is required, the microcontroller can increase its operating frequency. Software-selectable clock-divide operations allow flexibility, selecting whether a system clock cycle is 1, 2, 4, or 8 oscillator cycles. By performing this function in software, a lower power state can be entered without the cost of additional hardware.

For extremely power-sensitive applications, two additional low-power modes are available.

- Divide-by-256 power-management mode (PMM) (PMME = 1, CD1:0 = 00b)
- Stop mode (STOP = 1)

In PMM, one system clock is 256 oscillator cycles, significantly reducing power consumption while the microcontroller functions at reduced speed. The optional switchback feature allows enabled interrupt sources, such as the external interrupts and USARTs, to cause the processor to quickly exit PMM mode and return to a faster internal clock rate.

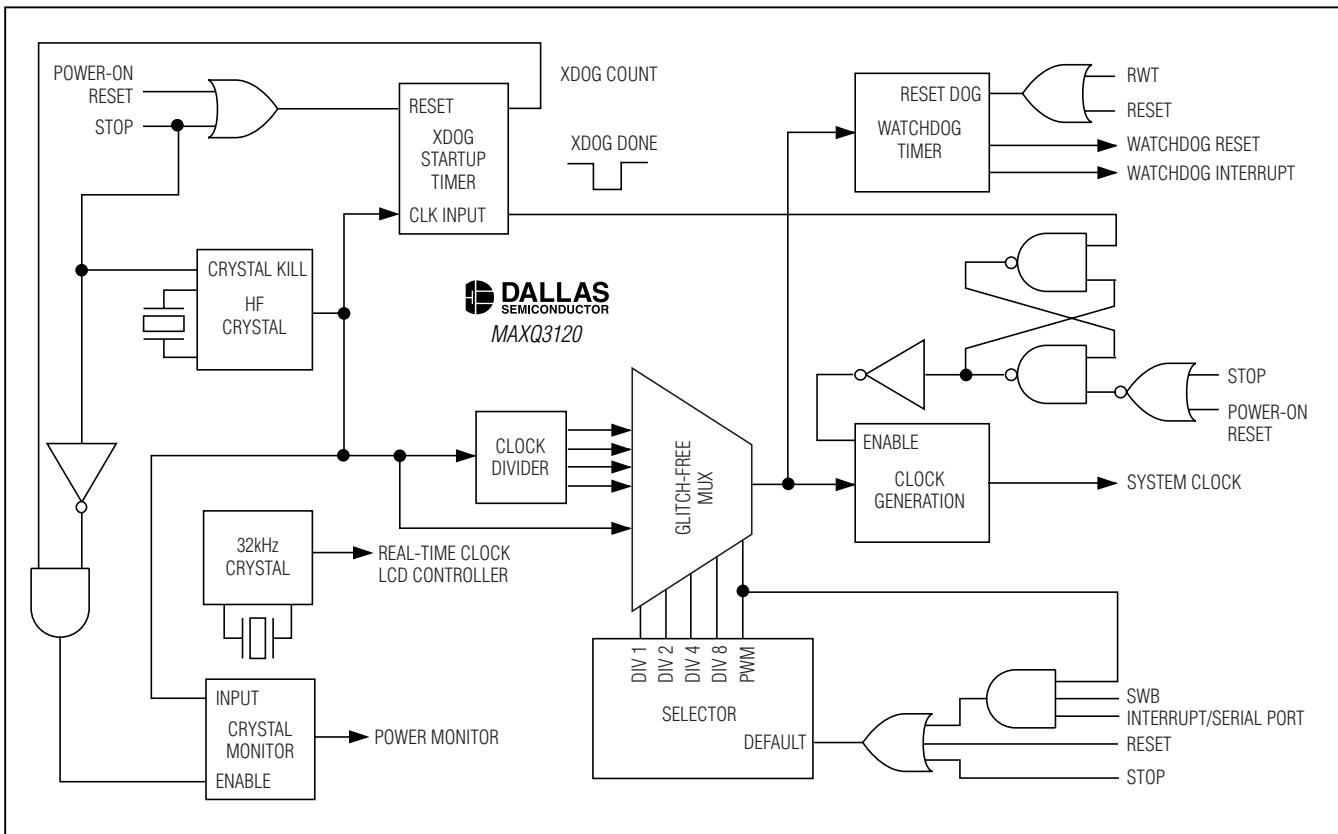

Figure 2. Clock Sources

High-Precision ADC Mixed-Signal Microcontroller

Power consumption reaches its minimum in stop mode. In this mode, the external high-frequency oscillator, system clock, and all code execution is halted. Stop mode is exited when an enabled external interrupt pin is triggered, an external reset signal is applied to the $\overline{\text{RESET}}$ pin, or the RTC time-of-day alarm is activated.

The 32kHz clock continues running during stop mode, enabling the following peripherals to keep running during stop mode.

- The RTC always continues running during stop mode.
- The LCD controller continues running during stop mode if it is running from the 32kHz clock (LCCS = 0).

Interrupts

Multiple reset sources are available for quick response to internal and external events. The MAXQ architecture uses a single interrupt vector (IV), single interrupt-service routine (ISR) design. For maximum flexibility, interrupts can be enabled globally, individually, or by module. When an interrupt condition occurs, its individual flag is set, even if the interrupt source is disabled at the local, module, or global level. Interrupt flags must be cleared within the user-interrupt routine to avoid repeated interrupts from the same source. Application software must ensure a delay between the write to the flag and the RETI instruction to allow time for the interrupt hardware to remove the internal interrupt condition. Asynchronous interrupt flags require a one-instruction delay and synchronous interrupt flags require a two-instruction delay.

When an enabled interrupt is detected, software jumps to a user-programmable interrupt vector location. The IV register defaults to 0000h on reset or power-up, so if it is not changed to a different address, the user program must determine whether a jump to 0000h came from a reset or interrupt source.

Once software control has been transferred to the ISR, the interrupt identification register (IIR) can determine if a system register or peripheral register was the source of the interrupt. The specified module can then be interrogated for the specific interrupt source and software can take appropriate action. Because the interrupts are evaluated by user software, the user can define a unique interrupt priority scheme for each application. The following interrupt sources are available.

- Watchdog Interrupt
- External Interrupts 0 to 2
- RTC Time-of-Day and Subsecond Alarms

- Serial Port 0 Receive and Transmit Interrupts
- Serial Port 1 Receive and Transmit Interrupts
- Timer 0 Overflow Interrupt
- Timer 1 Overflow and External Trigger Interrupts
- Timer 2 Low Compare, Low Overflow, Capture/Compare, and Overflow Interrupts

Reset Sources

Several reset sources are provided for microcontroller control. Although code execution is halted in the reset state, the high-frequency oscillator and the 32kHz oscillator continue to oscillate. Internal resets such as the power-on and watchdog resets assert the $\overline{\text{RESET}}$ pin low.

Power-On Reset

An internal power-on reset circuit enhances system reliability. This circuit forces the device to perform a power-on reset whenever a rising voltage on DVDD climbs above the VRST level. At this point, the following events occur:

- All registers and circuits enter their reset state (except for the RTC, if it is battery-backed)
- The POR flag (WDCN.7) is set to indicate the source of the reset
- Code execution begins at location 8000h

Watchdog Timer Reset

The watchdog timer functions are described in the *MAXQ Family User's Guide*. Execution resumes at location 8000h following a watchdog timer reset.

External System Reset

Asserting the external $\overline{\text{RESET}}$ pin low causes the device to enter the reset state. The external reset functions as described in the *MAXQ Family User's Guide*. Execution resumes at location 8000h after the $\overline{\text{RESET}}$ pin is released.

I/O Ports

The microcontroller uses the Type C and Type D bidirectional I/O ports described in the *MAXQ Family User's Guide*. The use of two port types allows for maximum flexibility when interfacing to external peripherals. Each port has eight independent, general-purpose I/O pins and three configure/control registers. Many pins support alternate functions such as timers or interrupts, which are enabled, controlled, and monitored by dedicated peripheral registers. Using the alternate function automatically converts the pin to that function.

High-Precision ADC Mixed-Signal Microcontroller

Type C port pins have Schmitt Trigger receivers and full CMOS output drivers, and can support alternate functions. The pin is either tri-stated or a weak pullup when defined as an input, dependent on the state of the corresponding bit in the output register.

Type D port pins have Schmitt Trigger receivers and full CMOS output drivers, and can support alternate functions. The pin is either tri-stated or a weak pullup when defined as an input, dependent on the state of the corresponding bit in the output register. All Type D pins also have interrupt capability.

High-Speed Hardware Multiplier

The hardware multiplier module performs high-speed multiply, square, and accumulate operations, and can complete a 16-bit x 16-bit multiply-and-accumulate operation in a single cycle. The hardware multiplier consists of two 16-bit parallel-load operand registers (MA, MB), a 40-bit accumulator that is formed by three

16-bit parallel registers (MC2, MC1, and MC0), and a status/control register (MCNT). Loading the registers can automatically initiate the operation, saving time on repetitive calculations. The accumulate function of the hardware multiplier is an essential element of digital filtering, signal processing, and proportional/integral/derivative (PID) algorithm-based control systems.

The hardware multiplier module supports the following operations:

- Multiply unsigned (16 bit x 16 bit)
- Multiply signed (16 bit x 16 bit)
- Multiply-accumulate unsigned (16 bit x 16 bit)
- Multiply-accumulate signed (16 bit x 16 bit)
- Square unsigned (16 bit)
- Square signed (16 bit)
- Square-accumulate unsigned (16 bit)
- Square-accumulate signed (16 bit)

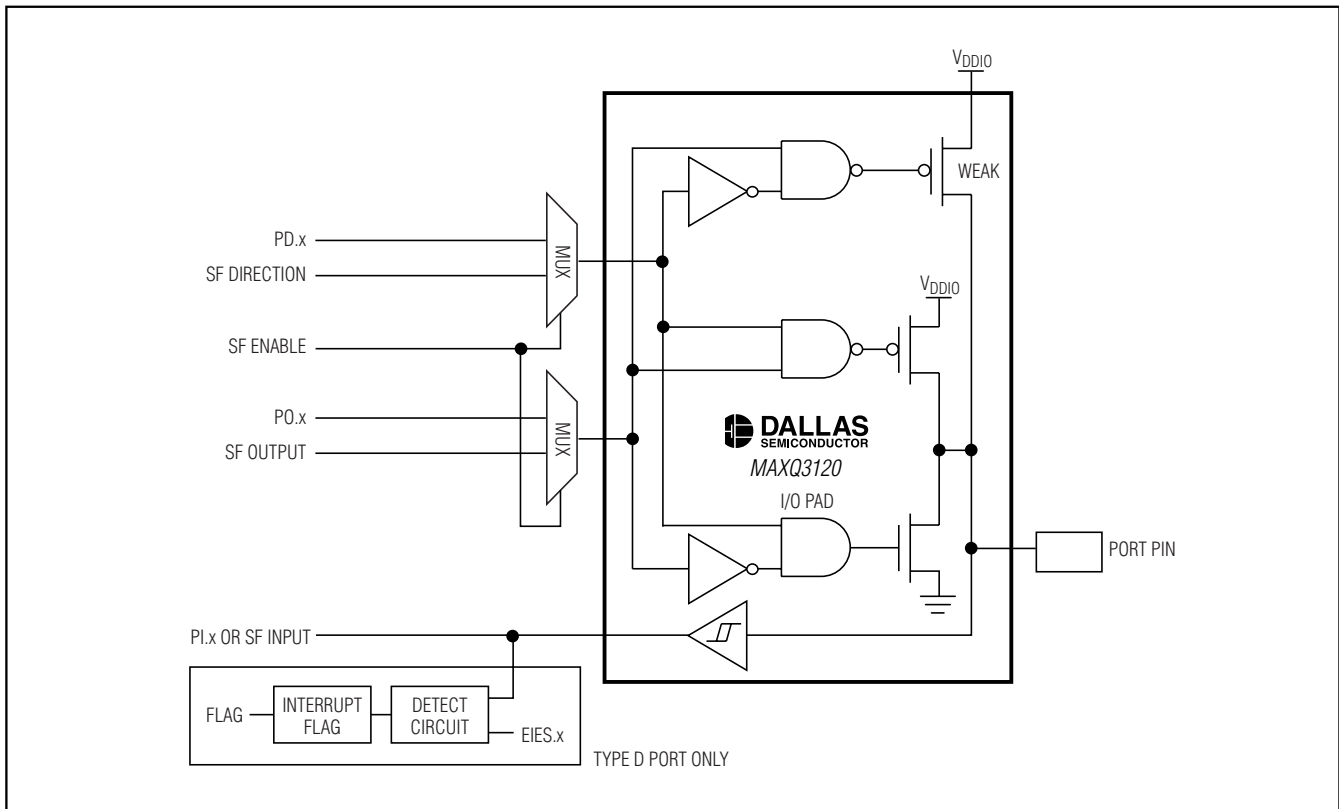

Figure 3. Type C/D Port Pin Schematic

High-Precision ADC Mixed-Signal Microcontroller

Real-Time Clock

A binary real-time clock keeps the time of day in absolute seconds with 1/256-second resolution. The 32-bit second counter can count up to approximately 136 years and be translated to calendar format by the application software. A time-of-day alarm and independent subsecond alarm can cause an interrupt, or wake the device from stop mode.

The independent subsecond alarm runs from the same RTC, and allows the application to perform periodic interrupts up to 8 seconds with a granularity of approximately 3.9ms. This creates an additional timer that can be used to measure long periods without performance degradations. Traditionally, long time periods have been measured using multiple interrupts from shorter programmable timers. Each timer interrupt required servicing, with each accompanying interruption slowing system operation. By using the RTC subsecond timer as a long-period timer, only one interrupt is needed, eliminating the performance hit associated with using a shorter timer.

An internal crystal oscillator clocks the RTC using integrated 6pF load capacitors, and gives the best performance when mated with a 32.768kHz crystal rated for a 6pF load. No external load capacitors are required. Higher accuracy can be obtained by using the digital RTC trim function. The frequency accuracy of a crystal-based oscillator circuit is dependent upon crystal accuracy, the match between the crystal and the oscillator capacitor load, ambient temperature, etc.

Programmable Timers

The MAXQ3120 incorporates one instance each of the timer 0, timer 1, and timer 2 peripherals. These timers can be used in counter/timer/capture/compare/PWM functions, allowing precise control of internal and external events. Timer 2 supports optional single-shot, external gating, and polarity control options as well as carrier generation support for infrared transmit/receive functions using serial port 0.

Timer 0

The timer 0 peripheral includes the following:

- 8-bit autoreload timer/counter
- 13-bit or 16-bit timer/counter
- Dual 8-bit timer/counter
- External pulse counter

Timer 1

The timer 1 peripheral includes the following:

- 16-bit autoreload timer/counter
- 16-bit capture
- 16-bit counter
- Clock generation output

Timer 2

The timer 2 peripheral includes the following:

- 16-bit autoreload timer/counter
- 16-bit capture
- 16-bit counter
- 8-bit capture and 8-bit timer
- 8-bit counter and 8-bit timer
- Infrared carrier generation support

Watchdog Timer

An internal watchdog timer greatly increases system reliability. The timer resets the processor if software execution is disturbed. The watchdog timer is a free-running counter designed to be periodically reset by the application software. If software is operating correctly, the counter is periodically reset and never reaches its maximum count. However, if software operation is interrupted, the timer does not reset, triggering a system reset and optionally a watchdog timer interrupt. This protects the system against electrical noise or electrostatic discharge (ESD) upsets that could cause uncontrolled processor operation. The internal watchdog timer is an upgrade to older designs with external watchdog devices, reducing system cost and simultaneously increasing reliability.

The watchdog timer is controlled through bits in the WDCN register. Its timeout period can be set to one of four programmable intervals ranging from 2^{12} to 2^{21} system clocks in its default mode, allowing flexibility to support different types of applications. The interrupt occurs 512 system clocks before the reset, allowing the system to execute an interrupt and place the system in a known, safe state before the device performs a total system reset. At 8MHz, watchdog timeout periods can be programmed from 512 μ s to 61.7s, depending on the system clock mode.

High-Precision ADC Mixed-Signal Microcontroller

MAXQ3120

In-Circuit Debug

Embedded debugging capability is available through the JTAG-compatible TAP. Embedded debug hardware and embedded ROM firmware provide in-circuit debugging capability to the user application, eliminating the need for an expensive in-circuit emulator. Figure 4 shows a block diagram of the in-circuit debugger. The in-circuit debug features include:

- Hardware debug engine
- Set of registers able to set breakpoints on register, code, or data accesses
- Set of debug service routines stored in the utility ROM

The embedded hardware debug engine is an independent hardware block in the microcontroller. The debug engine can monitor internal activities and interact with selected internal registers while the CPU is executing user code. Collectively, the hardware and software features allow two basic modes of in-circuit debugging:

- Background mode allows the host to configure and set up the in-circuit debugger while the CPU continues to execute the application software at full speed. Debug mode can be invoked from background mode.
- Debug mode allows the debug engine to take control of the CPU, providing read/write access to internal registers and memory, and single-step trace operation.

Serial Peripherals

The MAXQ3120 incorporates two 8051-style universal synchronous/asynchronous receiver/transmitters. The USARTs allow the device to conveniently communicate with other RS-232 interface-enabled devices, as well as PCs and serial modems when paired with an external RS-232 line driver/receiver. The dual independent USARTs can communicate simultaneously at different baud rates with two separate peripherals. The USART can detect framing errors and indicate the condition through a user-accessible software bit.

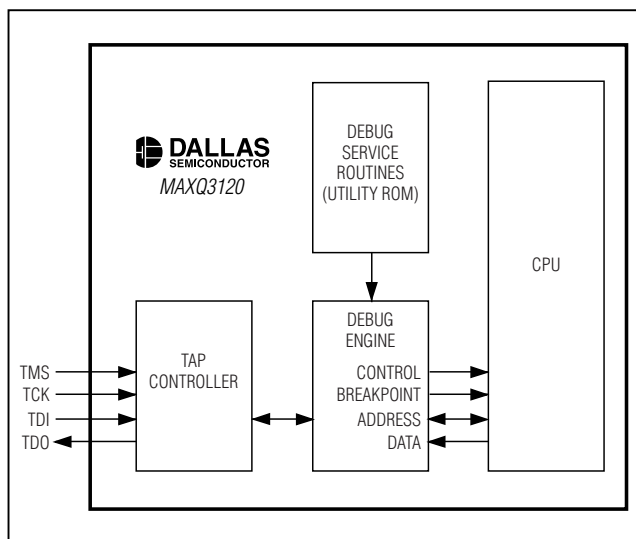

Figure 4. In-Circuit Debugger

The time base of the serial ports is derived from either a division of the system clock or the dedicated baud clock generator. The following table summarizes the operating characteristics as well as the maximum baud rate of each mode.

Serial port 0 contains additional functionality to support low-speed infrared transmission in combination with the PWM function of timer 2. When enabled in this mode, the serial port automatically outputs a waveform generated by combining the normal serial port output waveform with the PWM carrier waveform output by timer 2, using a logical OR or logical NOR function. The output of serial port 0 in this mode can be used to drive an infrared LED to communicate using a fixed-frequency carrier modulated signal. Depending on the drive strength required, the output may require a buffer when used for this purpose.

MODE	TYPE	START BITS	DATA BITS	STOP BIT	MAX BAUD RATE AT 8MHz
Mode 0	Synchronous	—	8	—	2Mbps
Mode 1	Asynchronous	1	8	1	250kbps
Mode 2	Asynchronous	1	8 + 1	1	250kbps
Mode 3	Asynchronous	1	8 + 1	1	250kbps

High-Precision ADC Mixed-Signal Microcontroller

LCD Driver

The MAXQ3120 microcontroller incorporates an LCD driver that interfaces to common low-voltage displays. By incorporating the LCD driver into the microcontroller, the design requires only an LCD glass rather than a considerably more expensive LCD module. Every character in an LCD glass is composed of one or more segments, each of which is activated by selecting the appropriate segment and common signal. The microcontroller can drive up to 112 LCD glass segments by multiplexing combinations of 28 segment (SEG0–SEG27) outputs and four common-signal outputs (COM0–COM3). Eight of the segment outputs can also be used as general-purpose port pins, if they are not needed to drive the LCD.

The segments are easily addressed by writing to dedicated display memory. Once the LCD driver settings and display memory have been initialized, the 14-byte display memory is periodically scanned, and the segment and common signals are generated automatically at the selected display frequency. No additional processor overhead is required while the LCD driver is running. Unused display memory can be used for general-purpose storage.

The design is further simplified and cost-reduced by the inclusion of software-adjustable internal voltage-dividers to control display contrast. If desired, contrast can also be controlled by an external resistance. The features of the LCD driver include the following:

- Automatic LCD segment and common-drive signal generation

- Four display modes supported:
 - Static (COM0)
 - 1/2 duty multiplexed with 1/2 bias voltages (COM0, COM1)
 - 1/3 duty multiplexed with 1/3 bias voltages (COM0, COM1, COM2)
 - 1/4 duty multiplexed with 1/3 bias voltages (COM0, COM1, COM2, COM3)
- Up to 28 segment outputs and four common-signal outputs
- 14 bytes (112 bits) of display memory
- Adjustable frame frequency
- Internal voltage-divider resistors eliminate requirement for external components
- Internal adjustable resistor allows contrast adjustment without external components
- Flexibility to use external resistors to adjust drive voltages and current capacity

A simple LCD-segmented glass interface example demonstrates the minimal hardware required to interface to a MAXQ3120 microcontroller. A two-character LCD is controlled, with each character containing seven segments plus decimal point. The LCD driver is configured for 1/2 duty cycle operation, meaning the active segment is controlled using a combination of segment signals, and COM0 or COM1 signals are used to select the active display.

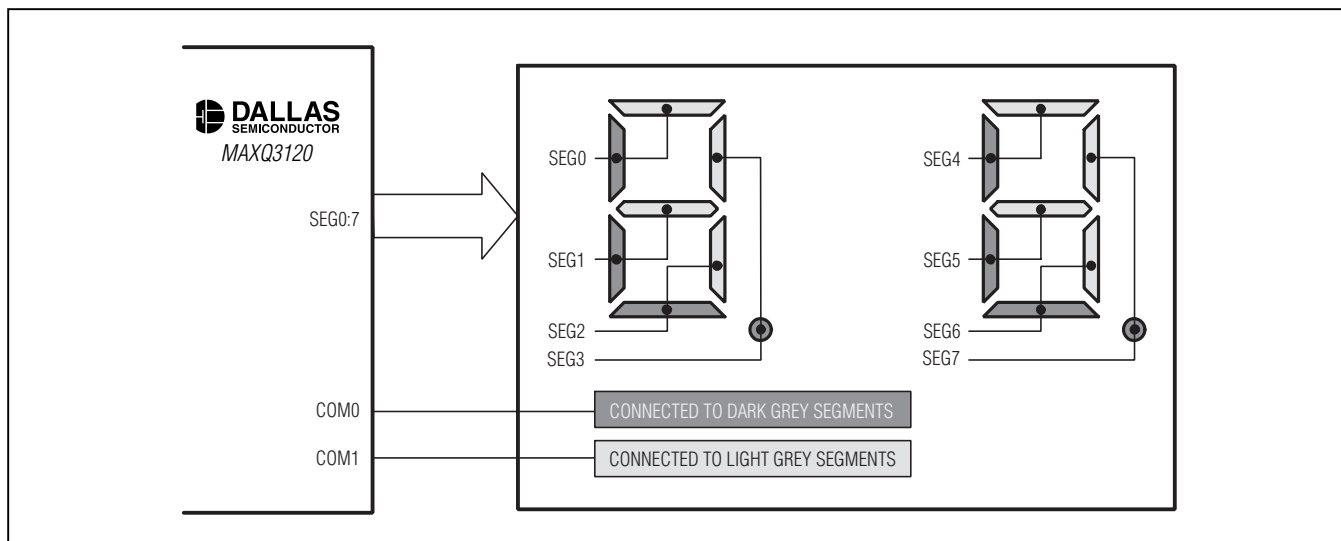

Figure 5. Two-Character, 1/2 Duty, LCD Interface Example

High-Precision ADC Mixed-Signal Microcontroller

Analog Front-End

The MAXQ3120 microcontroller incorporates an analog front-end for dedicated analog-to-digital conversion. This peripheral converts and digitally filters two differential signal channels with no CPU overhead.

The two conversion channels operate completely in parallel, running at the same sample rate whether one channel or both channels are enabled. If one or both channels are not in use, they may be powered down to conserve supply current.

The two input signals for each channel form a true differential pair. Each of the two signals (AN0+ and AN0- for channel 0, AN1+ and AN1- for channel 1) can vary across the entire +1V to -1V analog input range, without regard to the level of the other signal in the pair. The ini-

tial stage for each channel is a programmable gain function (1x, 16x) that can be set by software independently for each channel. Next, a second-order sigma-delta modulator samples each input signal.

When using both channels to measure the same signal (as is the case when measuring voltage and current for power calculations), a phase-correction buffer is provided to compensate for any phase shift between the two channels caused by external circuitry. The phase-correction buffer operates digitally on the output bit stream of one of the two channels and can delay either channel's bit stream with respect to the other channel's bit stream by up to 140 bits.

Next, the bit streams for the two channels travel through two digital sinc³ lowpass filters, which convert the bit streams to 16-bit PCM values for additional processing.

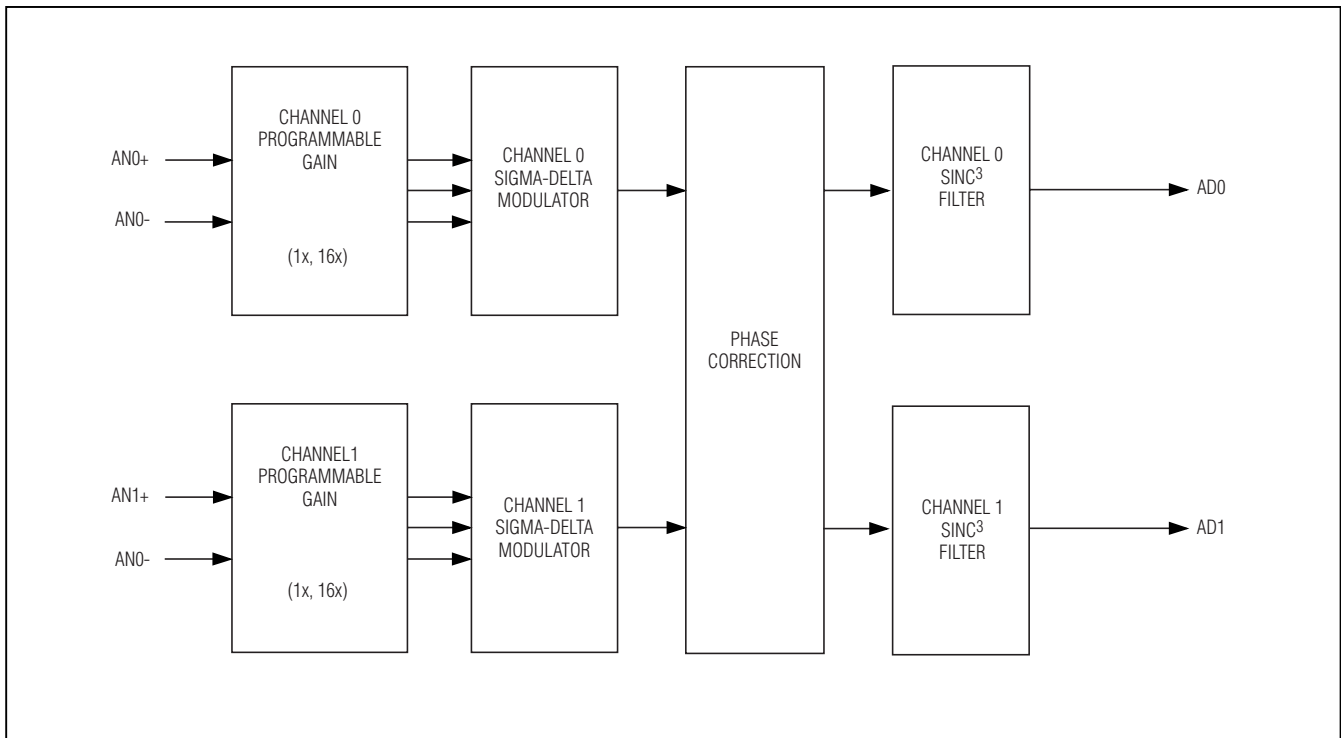

Figure 6. Analog Front-End Block Diagram

High-Precision ADC Mixed-Signal Microcontroller

Applications Information

The low-power, high-performance RISC architecture of the MAXQ3120 makes it an excellent fit for many portable or battery-powered applications that require cost-effective computing. The high-throughput core is complemented by a dual-differential channel, 16-bit sigma-delta ADC, and 16-bit hardware multiplier-accumulator, allowing the implementation of sophisticated computational algorithms. Applications benefit from a wide range of peripheral interfaces, allowing the microcontroller to communicate with many external devices. With integrated LCD support of up to 112 segments (4 x 28), applications can support complex user interfaces. Displays are driven directly with no additional external hardware required. Contrast can be adjusted using a built-in, adjustable resistor. The simplified architecture reduces component count and board space, critical factors in the design of portable systems.

The MAXQ3120 is ideally suited for single-phase electricity metering applications as well as other applications that require high-precision analog-to-digital conversion and signal processing.

Additional Documentation

Designers must have four documents to fully use all the features of this device. This data sheet contains pin descriptions, feature overviews, and electrical specifications. Errata sheets contain deviations from published specifications. The user's guides offer detailed information about programming, device features, and operation. The following documents can be downloaded from www.maxim-ic.com/microcontrollers.

- The MAXQ3120 data sheet, which contains electrical/timing specifications and pin descriptions, available at www.maxim-ic.com/MAXQ3120.
- The MAXQ3120 errata sheet, available at www.maxim-ic.com/errata.
- The *MAXQ Family User's Guide*, which contains detailed information on core features and operation, including programming, available at www.maxim-ic.com/MAXQUG.

- The *MAXQ Family User's Guide: MAXQ3120 Supplement*, which contains detailed information on features specific to the MAXQ3120, available at www.maxim-ic.com/MAXQ3120UG.

Development and Technical Support

A variety of highly versatile, affordably priced development tools for this microcontroller are available from Maxim/Dallas Semiconductor and third-party suppliers, including:

- Compilers
- In-circuit emulators
- Integrated development environments (IDEs)
- JTAG-to-serial converters for programming and debugging

A partial list of development tool vendors can be found on our website at www.maxim-ic.com/microcontrollers. Technical support is available through email at maxq.support@dalsemi.com.

Definitions

Offset Error

For an ideal converter, the first transition occurs at 0.5 LSB above zero. Offset error is the amount of deviation between the measured first transition point and the ideal point.

Gain Error

With a full-scale analog voltage applied to the ADC (resulting in all ones in the digital code), gain error is defined as the amount of deviation between the ideal transfer function and the measured transfer function (with the offset error removed). Gain error is usually expressed in LSB or as a percentage of full-scale range (%FSR).

Power-Supply Rejection Ratio

Power-supply rejection ratio (PSRR) is the ratio of changes in the power supply (V) to changes in the converter output (V). It is typically measured in decibels.

High-Precision ADC Mixed-Signal Microcontroller

MAXQ3120

Appendix A: Applying a Lowpass Filter (LPF) for Application-Optimized ADC Performance

The MAXQ3120 gives a user application program direct access to the ADC data stream right after its sinc3 filters. This unique feature permits the MAXQ3120 to be optimized for its target applications. With the device's 8MIPS processing power and the 1-cycle MAC, a linear FIR filter can be easily computed in the user application program. This section provides a simple LP FIR filter to improve the SNR and THD performance of the MAXQ3120 for the power-metering application.

Filter Specifications and Coefficients

Input signal frequency (f_{IN}) = 60Hz

Sampling frequency (f_s) = 20833Hz

Window = hamming

Cutoff frequency (attenuates after 7th harmonic) = 0.06π = 625Hz

Cutoff frequency (for 21st harmonic) = 0.18π = 1875Hz

Transition width = 0.35π = 3646Hz

Filter length = 23

- 1) LPF coefficients (up to 21st harmonic). Note that these coefficients have been converted to 16-bit fixed-point numbers. A shift of 17 places is required after the multiply-accumulate operation.

FILTER_COEFFICIENT_0	-19	FILTER_COEFFICIENT_12	21893
FILTER_COEFFICIENT_1	-288	FILTER_COEFFICIENT_13	17547
FILTER_COEFFICIENT_2	-786	FILTER_COEFFICIENT_14	11739
FILTER_COEFFICIENT_3	-1402	FILTER_COEFFICIENT_15	6018
FILTER_COEFFICIENT_4	-1670	FILTER_COEFFICIENT_16	1627
FILTER_COEFFICIENT_5	-876	FILTER_COEFFICIENT_17	-876
FILTER_COEFFICIENT_6	1627	FILTER_COEFFICIENT_18	-1670
FILTER_COEFFICIENT_7	6018	FILTER_COEFFICIENT_19	-1402
FILTER_COEFFICIENT_8	11739	FILTER_COEFFICIENT_20	-786
FILTER_COEFFICIENT_9	17547	FILTER_COEFFICIENT_21	-288
FILTER_COEFFICIENT_10	21893	FILTER_COEFFICIENT_22	-19
FILTER_COEFFICIENT_11	23506	—	—

- 2) LPF coefficients (up to 7th harmonic). Note that these coefficients have been converted to 16-bit fixed-point numbers. A shift of 18 places is required after the multiply-accumulate operation.

FILTER_COEFFICIENT_0	849	FILTER_COEFFICIENT_12	23295
FILTER_COEFFICIENT_1	1420	FILTER_COEFFICIENT_13	21720
FILTER_COEFFICIENT_2	2553	FILTER_COEFFICIENT_14	19291
FILTER_COEFFICIENT_3	4334	FILTER_COEFFICIENT_15	16269
FILTER_COEFFICIENT_4	6754	FILTER_COEFFICIENT_16	12966
FILTER_COEFFICIENT_5	9700	FILTER_COEFFICIENT_17	9700
FILTER_COEFFICIENT_6	12966	FILTER_COEFFICIENT_18	6754
FILTER_COEFFICIENT_7	16269	FILTER_COEFFICIENT_19	4334
FILTER_COEFFICIENT_8	19291	FILTER_COEFFICIENT_20	2553
FILTER_COEFFICIENT_9	21720	FILTER_COEFFICIENT_21	1420
FILTER_COEFFICIENT_10	23295	FILTER_COEFFICIENT_22	849
FILTER_COEFFICIENT_11	23840	—	—

High-Precision ADC Mixed-Signal Microcontroller

Filter Results

Below is the summary of the SNR and THD values before and after applying the above LPFs, for 60 MAXQ3120 units.

An application engineer can easily implement his own favorite lowpass filters to optimize MAXQ3120 for his target applications. However, he does need to consider

the filter complexity and its processor resource requirement (CPU cycles and storage space) to strike an optimal balance. The above 23-tap LPF takes 23 x 2 bytes of RAM and 107 clock cycles of the MAXQ3120 to complete. Note that the number of cycles varies from filter to filter because the number of shifts required to normalize the multiply-accumulate result will vary.

CONDITION	SNR			THD		
	MIN	AVG	MAX	MIN	AVG	MAX
Before LPF	56.5	56.8	57.1	-84.5	-81.1	-77.3
After LPF, 21st Harmonic	68.2	70.7	71.4	-85.8	-83.1	-79.4
After LPF, 7th Harmonic	71.5	73.8	74.7	-88.9	-85.7	-82.0

Selector Guide

PART	TEMP RANGE	PROGRAM MEMORY	DATA MEMORY	LCD SEGMENTS	EXTERNAL INTERRUPTS	USARTS	PIN-PACKAGE
MAXQ3120-FFN	-40°C to +85°C	16kWord Flash	256 Word SRAM	112	3	2	80 MQFP
MAXQ3120-FFN+	-40°C to +85°C	16kWord Flash	256 Word SRAM	112	3	2	80 MQFP

+Denotes a Pb-free/RoHS-compliant device.

High-Precision ADC Mixed-Signal Microcontroller

Pin Configuration

MAXQ3120

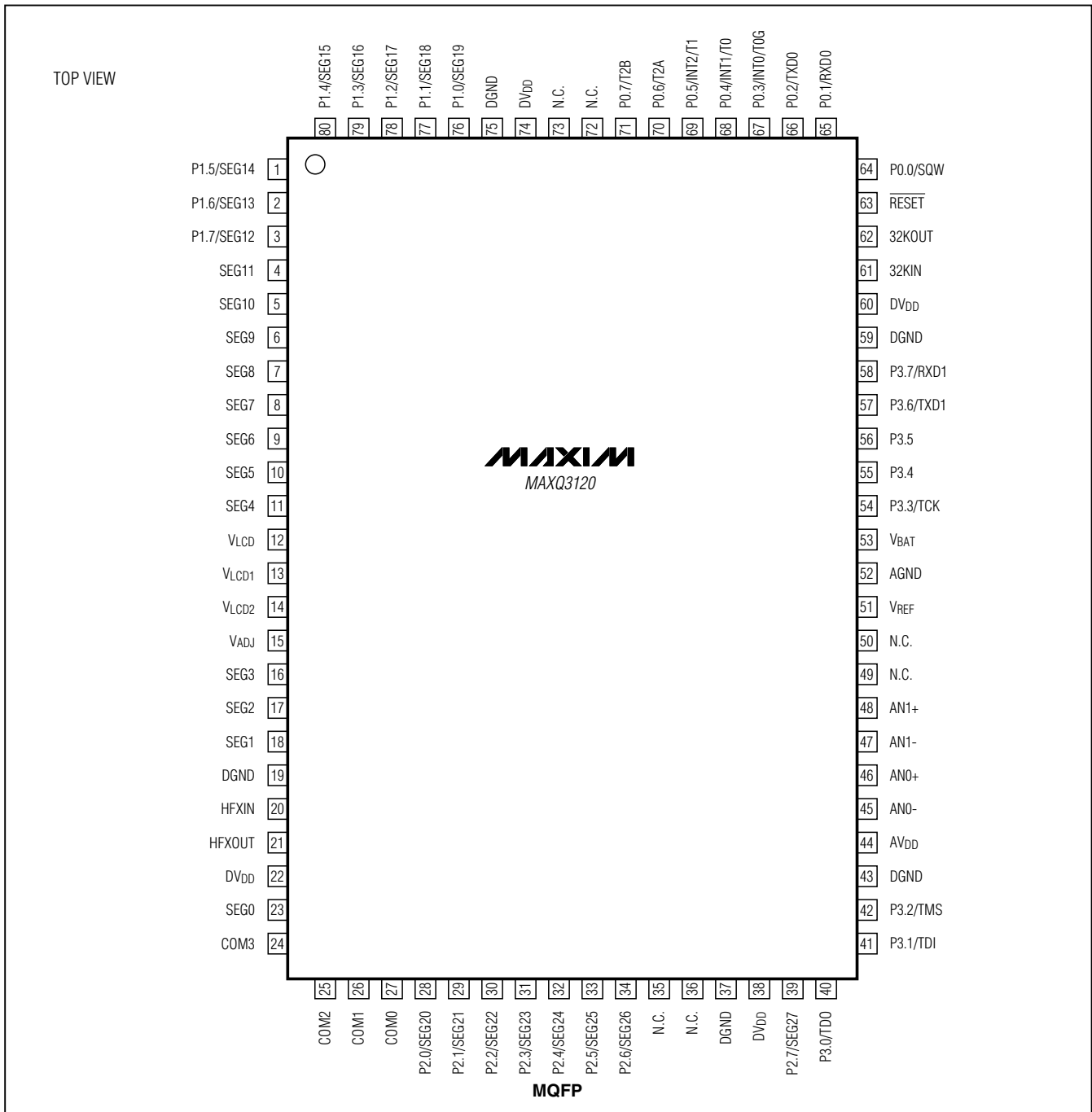

High-Precision ADC Mixed-Signal Microcontroller

Typical Operating Circuit

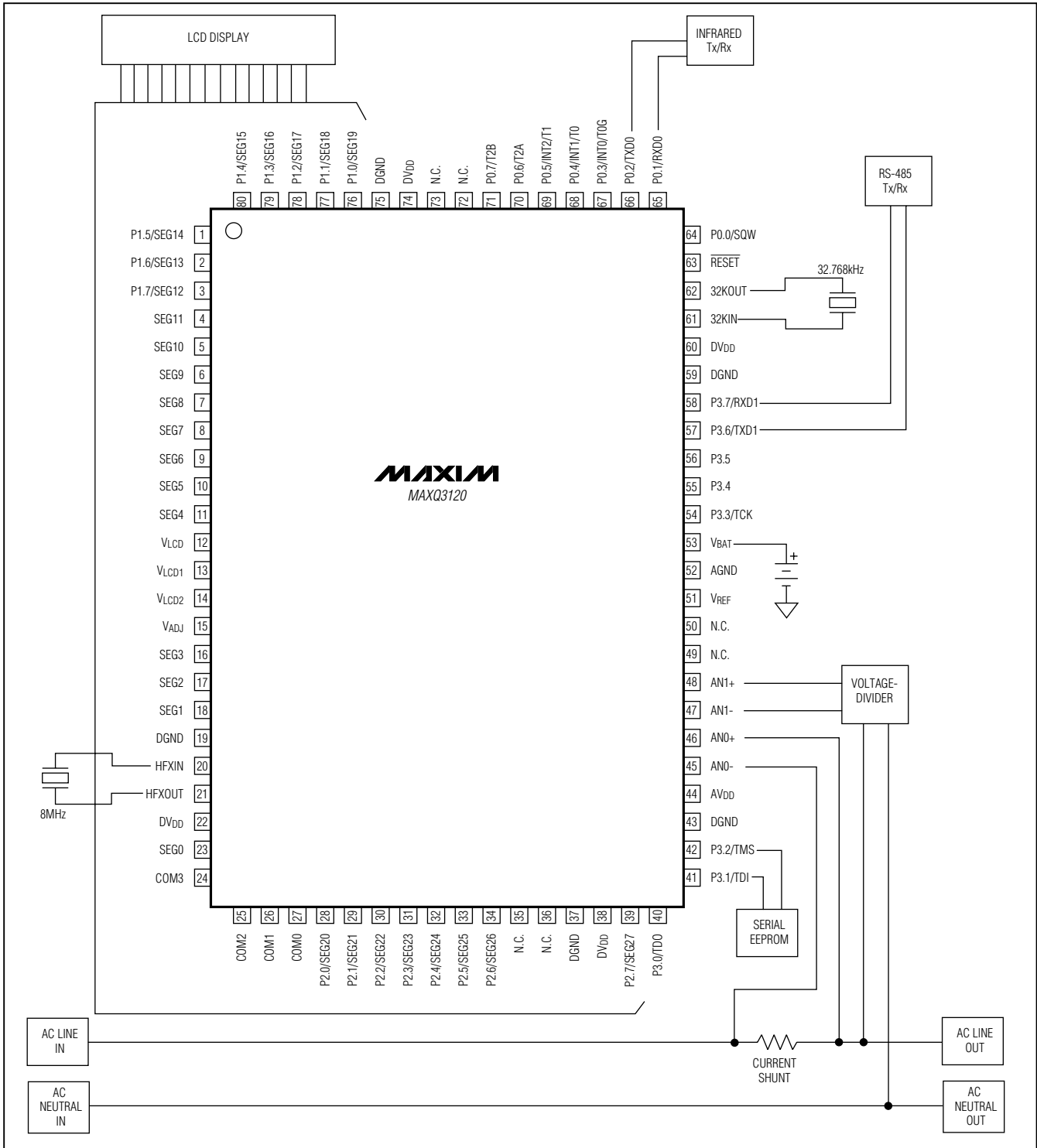

High-Precision ADC Mixed-Signal Microcontroller

MAXQ3120

Package Information

(The package drawing(s) in this data sheet may not reflect the most current specifications. For the latest package outline information, go to www.maxim-ic.com/DallasPackInfo).

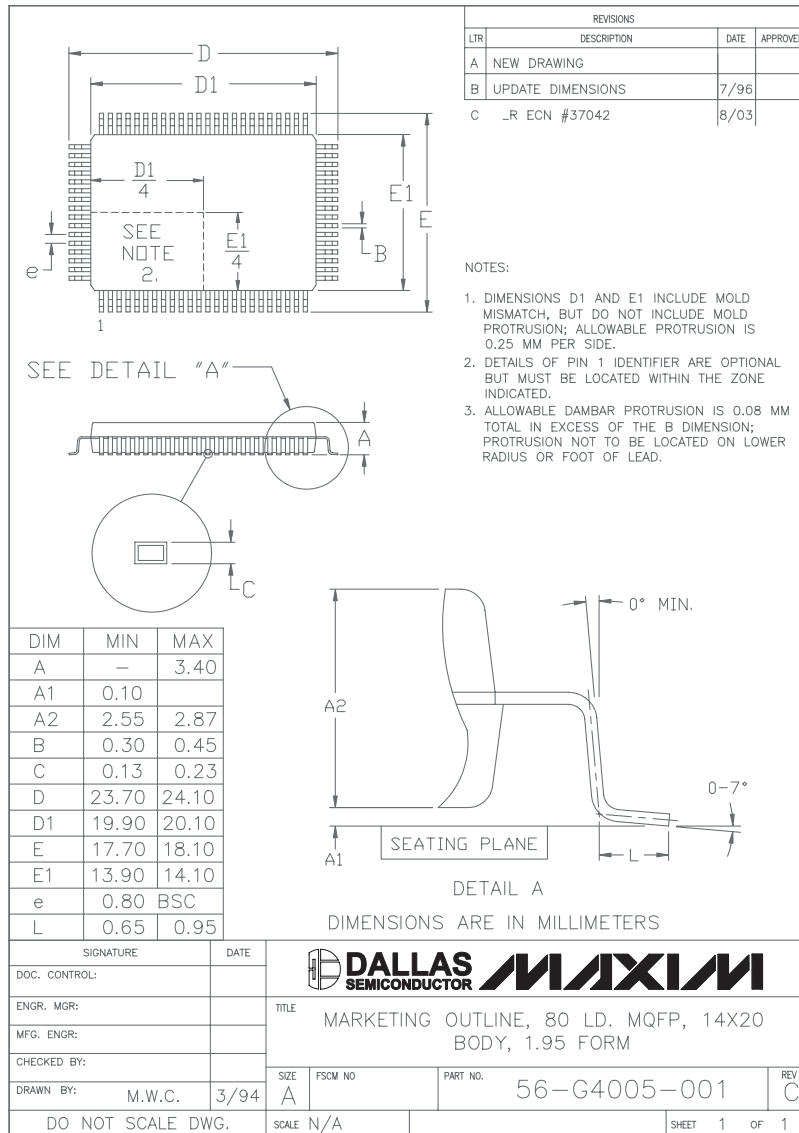

Revision History

- Rev 0; 7/05: Original release.
- Rev 1; 8/05: Added clarification to ADC Resolution condition (No missing codes, with software lowpass filter, see Appendix A).
Deleted paragraph on Integral Nonlinearity.

Maxim cannot assume responsibility for use of any circuitry other than circuitry entirely embodied in a Maxim product. No circuit patent licenses are implied. Maxim reserves the right to change the circuitry and specifications without notice at any time.

Maxim Integrated Products, 120 San Gabriel Drive, Sunnyvale, CA 94086 408-737-7600 _____ **33**