

<h1>NAIS</h1>	HIGHLY RELIABLE DIN SIZE LIMIT SWITCHES	<h1>AZ55 Limit Switches</h1>
---------------	--	----------------------------------



- Design conforms to DIN size
Mounting distance and dimensions: DIN43694
Screw hole for conduit: DIN40430 Pg13.5
- Utilizes the same basic switch as the AZ5 series

PRODUCT TYPE

Actuator	Part No.
Plunger	AZ5501
Roller plunger	AZ5502
Flexible rod	AZ5506
Roller arm	AZ5524
Adjustable rod	AZ5527
Adjustable roller arm	AZ5528

SPECIFICATIONS

Rating

Rated control voltage		125V AC	250V AC	115V DC
Resistive load ($\cos\phi = 1$)		10A	6A	0.8A
Inductive load ($\cos\phi = 0.4$)		6A	4A	0.1A
Motor or lamp load	N.C. contact	4A	2.5A	0.1A
	N.O. contact	2A	1.2A	0.1A

Characteristics

Contact arrangement		1 Form Z
Initial contact resistance, max.		25mΩ
Initial insulation resistance (At 500V DC)		Min. 100MΩ
Initial breakdown voltage		1,000Vrms for 1 min Between terminals 1,500Vrms for 1 min Between dead metal parts and each terminal 1,500Vrms for 1 min Between ground and each terminal
Shock resistance		Max. 30G
Vibration resistance		55Hz, double amplitude of 1.5mm
Expected life (Min. operations)	Mechanical	10 ⁷ (at 50 cpm)
	Electrical	5x10 ⁵ (at 20 cpm, rated load)
Ambient temperature		+5 to +80°C +41 to +176°F
Ambient humidity		Max. 95%R.H.



AZ55

Operating Characteristics

Actuator	Operating Force (O.F.), max. (g oz)	Release Force (R.F.), min. (g oz)	Pretravel (P.F.), max. (mm inch)	Movement Differential (M.D.), max. (mm inch)	Overtravel (O.T.), min. (mm inch)
Plunger	2,720 95.95	910 32.10	1.7 .067	1.0 .039	6.4 .252
Roller plunger	2,720 95.95	910 32.10	1.7 .067	1.0 .039	5.6 .220
Flexible rod ¹⁾	142 5.01	—	29 1.142	—	—
Roller arm	900 31.75	50 1.76	18° to 25°	15°	60°
Adjustable rod ²⁾	244 8.61	14 .49	18° to 25°	15°	60°
Adjustable roller arm ³⁾	900 31.75	50 1.76	18° to 25°	15°	60°

- Notes: 1) Characteristics measured at the top of rod.
 2) Characteristics measured at the center distance of 141mm 5.551 inch.
 3) Characteristics measured at the center distance of 38.1mm 1.500 inch.

DIMENSIONS

• Plunger type



AZ5501

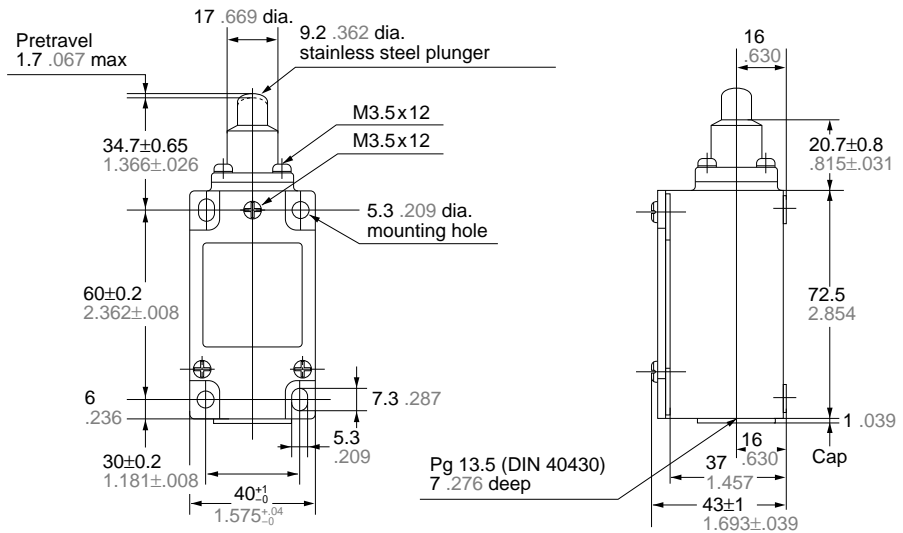

mm inch

• Roller plunger type



AZ5502

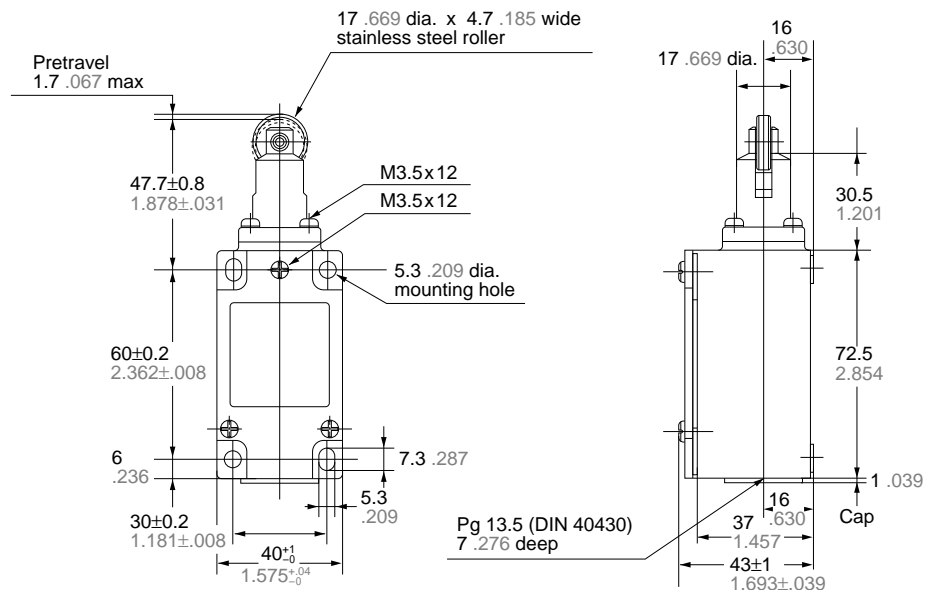

General tolerance: ±0.4 ±.016

AZ55

• Flexible rod type



AZ5506

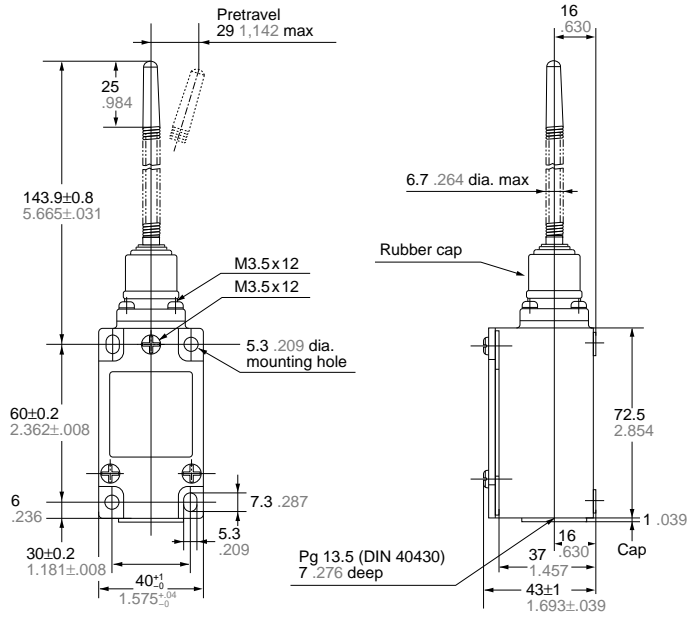

mm inch

• Roller arm type

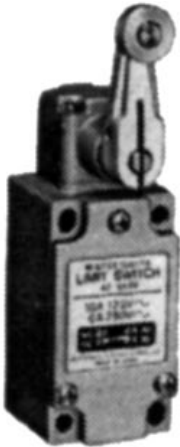

AZ5524

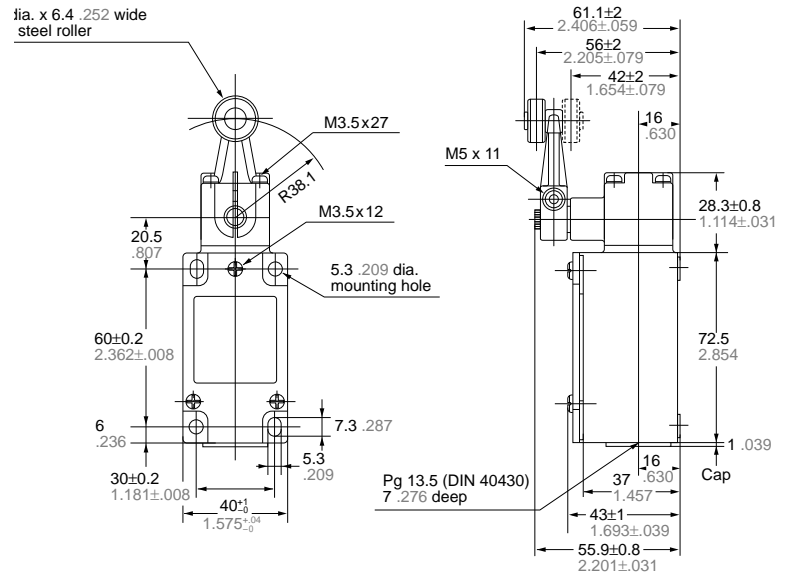

• Adjustable rod type



AZ5527

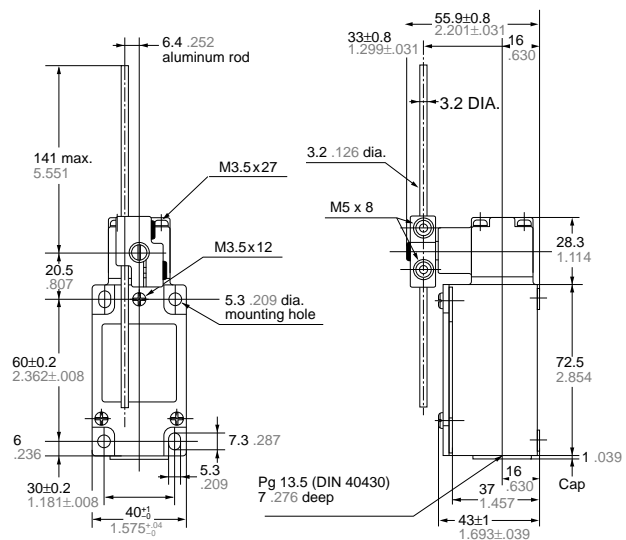

General tolerance:
±0.4 ±.016

AZ55

• Adjustable roller arm type

mm inch



AZ5528

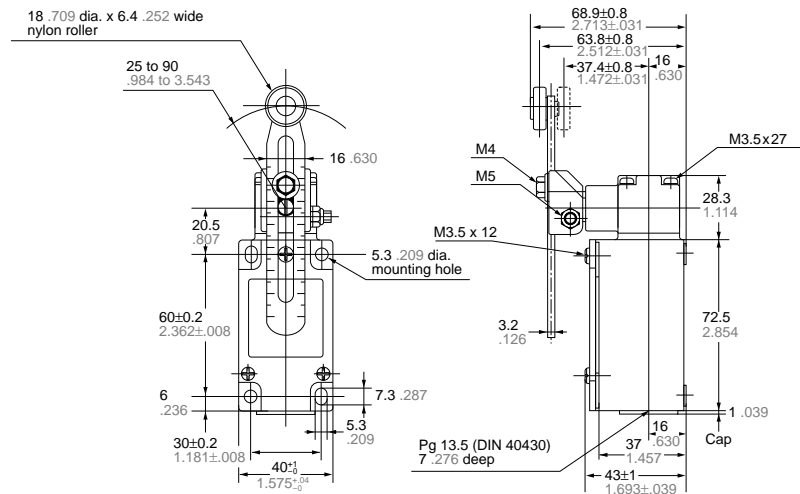

General tolerance: ±0.4 ±.016

ADJUSTING METHOD

Adjustable roller

1) A rotary actuator can be set and locked in any

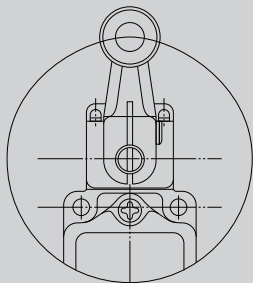

2) An actuator head may be moved in 90° increments to any of four directions, by removing the four head screws.

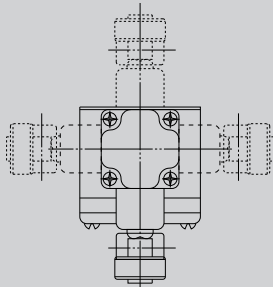

3) A roller lever may be faced in or out.

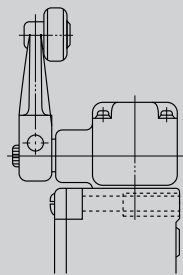

Adjustable head

An actuator may be moved in 90° increments by removing the four actuator screws.

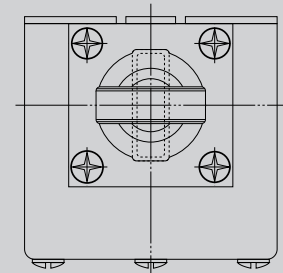

DIN STANDARDS

1. Mounting distance and dimensions meet DIN43694.
2. Protective construction meets IEC IP65, but insulation distance and terminal construction do not meet VDE standards.
3. Operating position of AZ5501 and AZ5502 meet DIN43694.
4. There are no DIN standards specified for the operating position of AZ5506 and AZ5528. Only mounting distance and dimensions meet DIN43694.