

NEC

6 AND 8 PIN DIP 400 V BREAKDOWN VOLTAGE NORMALLY CLOSED TYPE 1-CH, 2-CH OPTICAL COUPLED MOSFET

PS7141-1B,-2B
PS7141L-1B,-2B

FEATURES

- **1 CHANNEL TYPE:**
(1b output)
- **2 CHANNEL TYPE:**
(1b + 1b output)
- **DESIGNED FOR AC/DC SWITCHING LINE CHANGER**
- **SMALL PACKAGE:**
6 and 8 pin DIP
- **LOW OFFSET VOLTAGE**
- **LOW LED OPERATING CURRENT:**
 $I_F = 2 \text{ mA}$
- **SURFACE MOUNT TYPE LEAD:**
PS7141L-1B,-2B

DESCRIPTION

The PS7141-1B,-2B and PS7141L-1B,-2B are solid state relays containing GaAs LEDs on the light emitting side (input side) and normally closed (N.C.) contact MOS FETs on the output side. They are suitable for analog signal control because of their low offset and high linearity.

APPLICATIONS

- EXCHANGE EQUIPMENT
- MEASUREMENT EQUIPMENT
- FA/OA EQUIPMENT

ELECTRICAL CHARACTERISTICS (TA = 25 °C)

		PART NUMBER		PS7141-1B,-2B, PS7141L-1B,-2B		
	SYMBOLS	PARAMETERS	UNITS	MIN	TYP	MAX
Diode	V _F	Forward Voltage, I _F = 10 mA	V		1.2	1.4
	I _R	Reverse Current, V _R = 5 V	μA			5.0
MOS FET	I _{LOFF}	Off-State Leakage Current, I _F = 10 mA, V _D = 400 V	μA		0.03	1.0
	C _{out}	Output Capacitance, V _D = 0 V, f = 1 MHz, I _F = 10 mA	pF/ch		185	
Coupled	I _{Foff}	LED Off-state Current, I _L = 150 mA	mA			2.0
	R _{ON1}	On-State Resistance I _F = 0 mA, I _L = 10 mA	Ω		20	30
				R _{ON2}	I _F = 0 mA, I _L = 150 mA, t ≤ 10 ms	16
	t _{ON}	Turn-on Time ¹ I _F = 10 mA, V _O = 5 V, PW ≥ 10 ms	ms		0.02	0.2
	t _{OFF}	Turn-off Time ¹ I _F = 10 mA, V _O = 5 V, PW ≥ 10 ms	ms		0.2	1.0
	R _{I-O}	Isolation Resistance, V _{I-O} = 1.0 kVdc	Ω	10 ⁹		
	C _{I-O}	Isolation Capacitance, V = 0 V, f = 1 MHz	pF/ch		1.1	

Notes:

1. Turn-on, Turn-off Time.

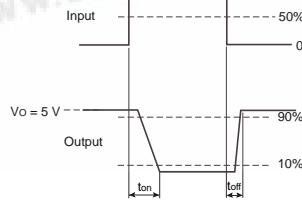
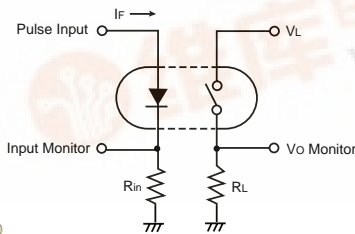

PS7141-1B,
PS7141L-1B

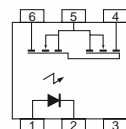

PS7141-2B,
PS7141L-2B

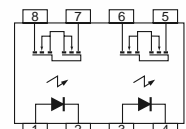

PS7141-1B,-2B, PS7141L-1B,-2B

ABSOLUTE MAXIMUM RATINGS¹ (T_A = 25°C)

SYMBOLS	PARAMETERS	UNITS	RATINGS	
			PS7141-1B PS7141L-1B	PS7141-2B PS7141L-2B
Diode				
I _F	Forward Current (DC)	mA	50	
V _R	Reverse Voltage	V	5.0	
P _D	Power Dissipation	mW/ch	50	
I _{FP}	Peak Forward Current ²	A	1	
MOSFET				
V _L	Break Down Voltage	V	400	
I _L	Continuous Load Current ³	mA	150	
	Connection A		200	–
	Connection B		300	–
I _{LP}	Pulse Load Current ⁴	mA	300	
	AC/DC Connection			
P _D	Power Dissipation	mW/ch	560	375
Coupled				
BV	Isolation Voltage ⁵	Vr.m.s.	1500	
P _T	Total Power Dissipation	mW	610	850
T _A	Operating Ambient Temp.	°C	-40 to +80	
T _{STG}	Storage Temperature	°C	-40 to +100	

Notes:

1. Operation in excess of any one of these parameters may result in permanent damage.
2. PW = 100 μs, Duty Cycle = 1 %.
3. Conditions: I_F ≥ 2 mA. The following types of load connections are available:

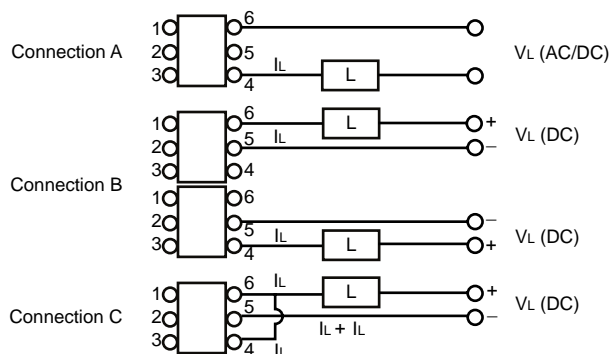

4. PW = 100 ms, 1 shot.
5. AC voltage for 1 minute at T_A = 25 °C, RH = 60 % between input and output.

RECOMMENDED OPERATING CONDITIONS (T_A = 25°C)

PART NUMBER		PS7141-1B,-2B, PS7141L-1B,-2B			
SYMBOLS	PARAMETERS	UNITS	MIN	TYP	MAX
I _F	LED Operating Current	mA	2	10	20
V _F	LED Off Voltage	V	0		0.5

ORDERING INFORMATION

PART NUMBER	PACKAGE	PACKING STYLE
PS7141-1B	6-pin DIP	Magazine case 50 pcs
PS7141L-1B		
PS7141L-1B-E3		Embossed Tape 1,000 pcs/reel
PS7141L-1B-E4		
PS7141-2B	8-pin DIP	Magazine case 50 pcs
PS7141L-2B		
PS7141L-2B-E3		Embossed Tape 1,000 pcs/reel
PS7141L-2B-E4		

PS7141-1B,-2B, PS7141L-1B,-2B

OUTLINE DIMENSIONS (Units in mm)

PS7141-1B

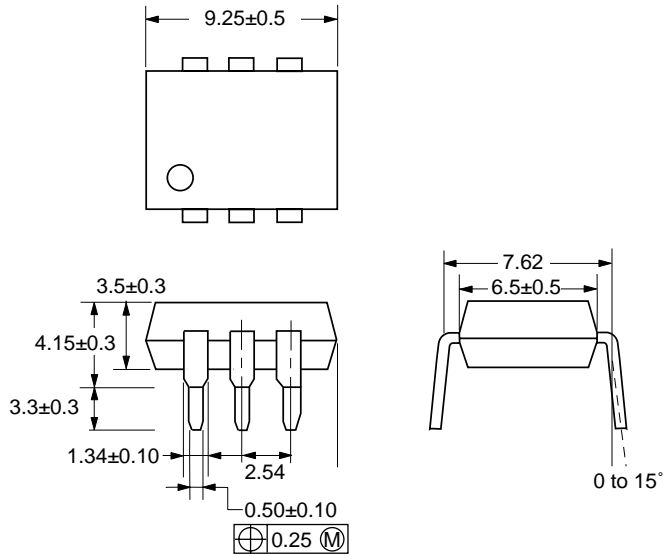

PS7141L-1B

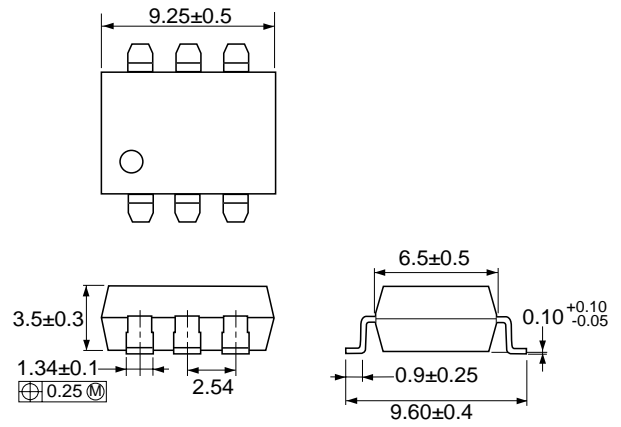

PS7141-2B

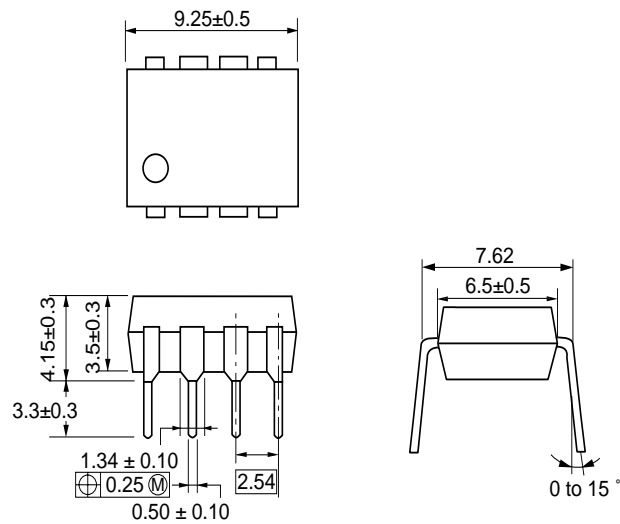

PS7141L-2B

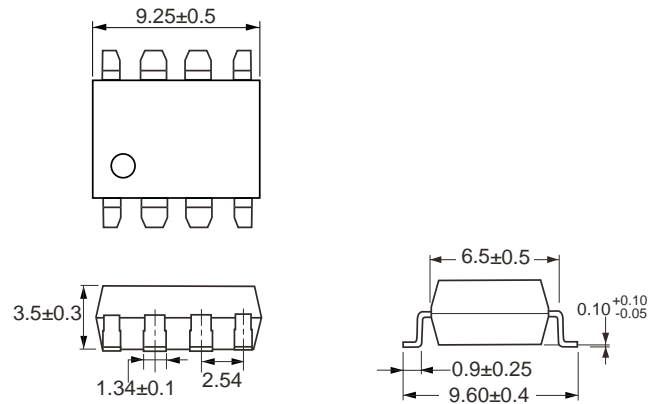

PIN CONNECTION (Top View)

PS7141-1B, PS7141L-1B

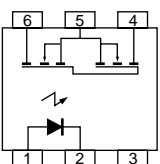

1. LED Anode
2. LED Cathode
3. NC
4. MOSFET Source
5. MOSFET Drain
6. MOSFET Source

PS7141-2B, PS7141L-2B

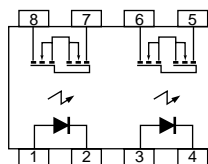

1. LED Anode 1
2. LED Cathode 1
3. LED Anode 2
4. LED Cathode 2
5. MOSFET 2
6. MOSFET 2
7. MOSFET 1
8. MOSFET 1

PS7141-1B,-2B, PS7141L-1B,-2B

TYPICAL PERFORMANCE CURVES (T_A = 25 °C)

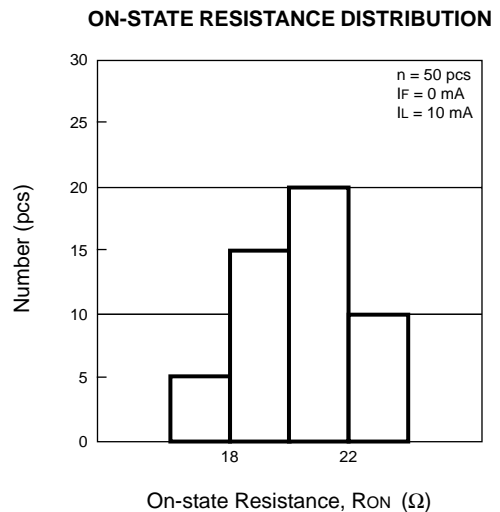
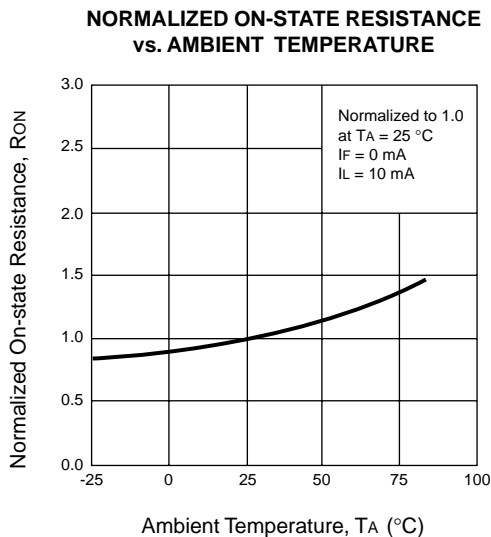
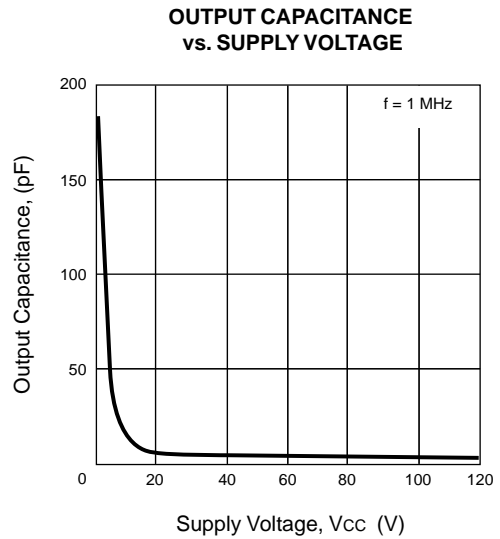
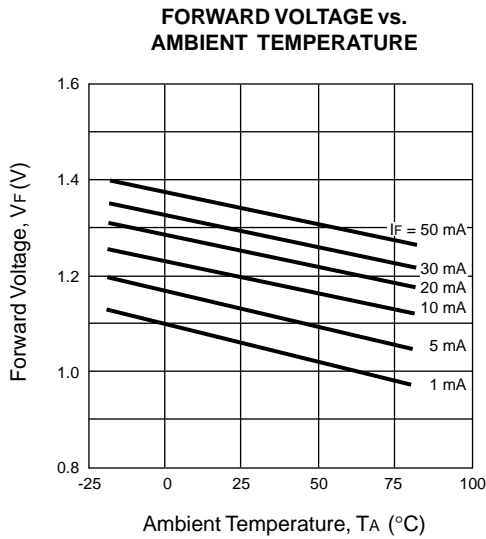
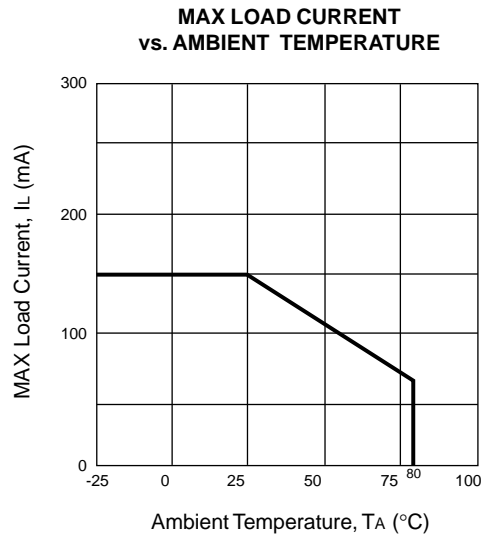
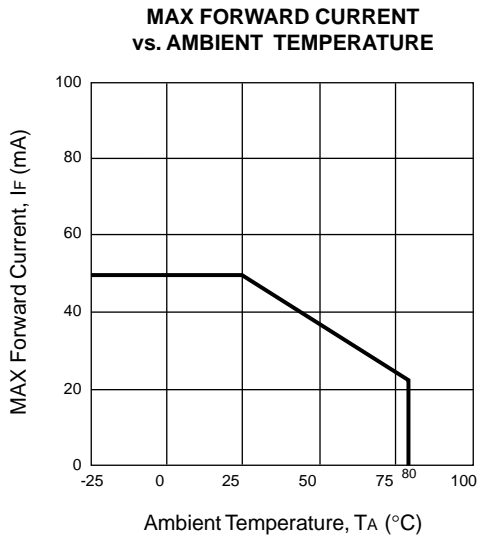

TYPICAL PERFORMANCE CURVES (TA = 25 °C)

OFF-STATE LEAKAGE CURRENT vs. SUPPLY VOLTAGE

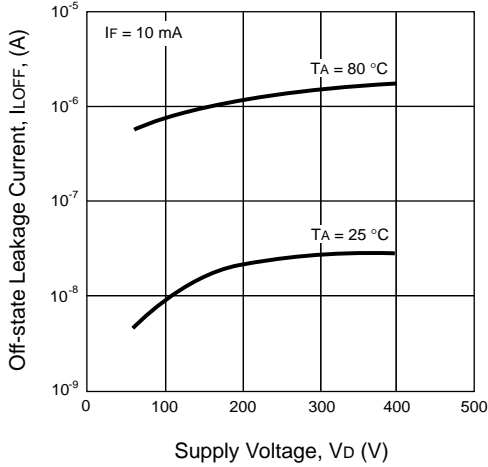

LOAD CURRENT vs. LOAD VOLTAGE

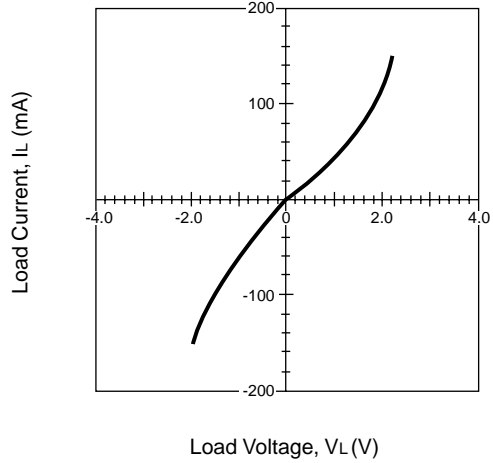

TURN-ON TIME VS. FORWARD CURRENT

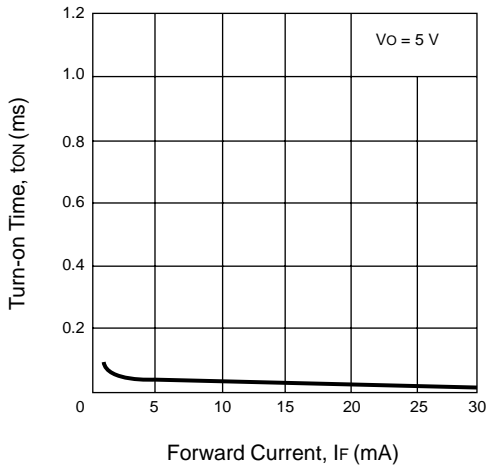

TURN-OFF TIME VS. FORWARD CURRENT

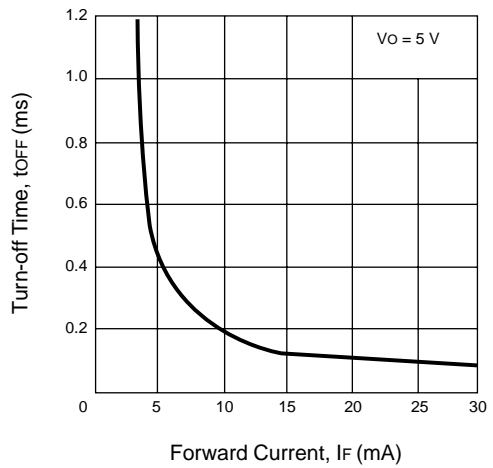

TURN-ON TIME DISTRIBUTION

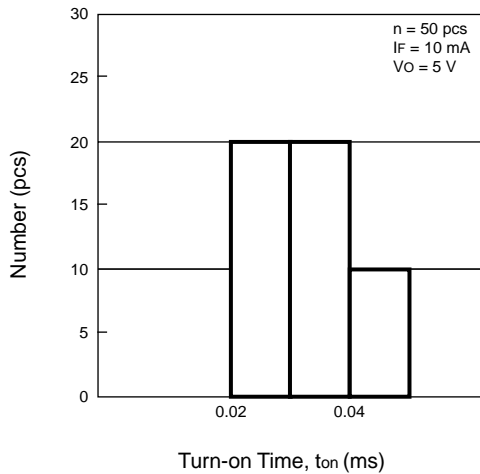

TURN-OFF TIME DISTRIBUTION

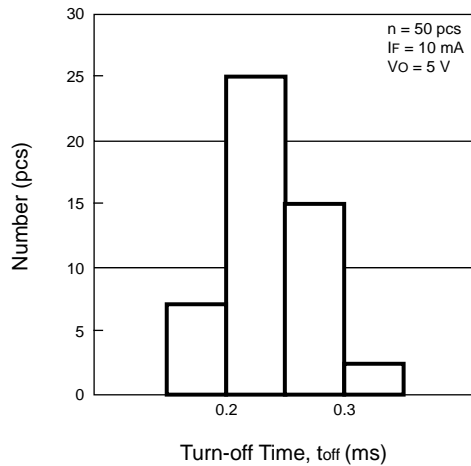

PS7141-1B,-2B, PS7141L-1B,-2B

TYPICAL PERFORMANCE CURVES (TA = 25 °C)

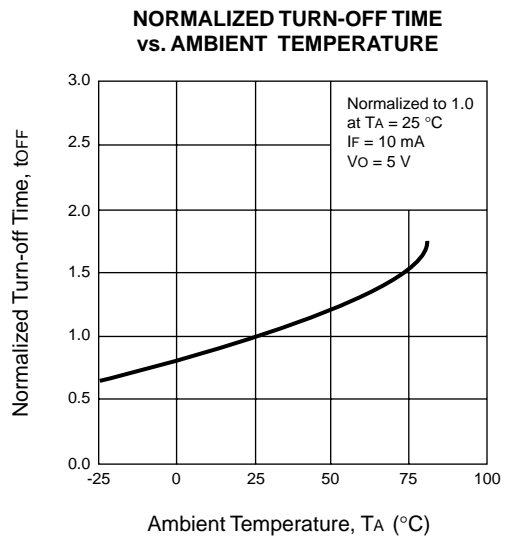
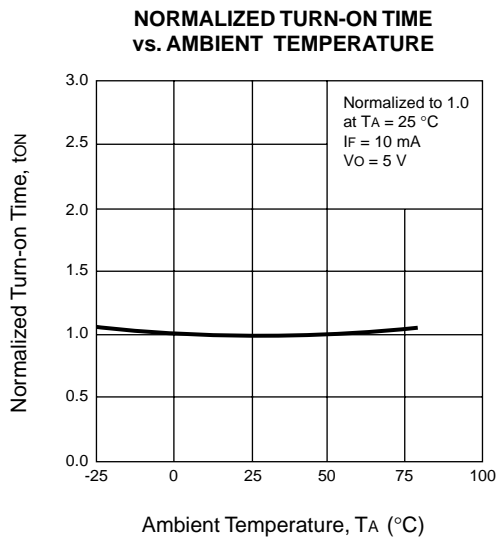

TAPING SPECIFICATIONS (Units in mm)

OUTLINE AND DIMENSIONS (TAPE)

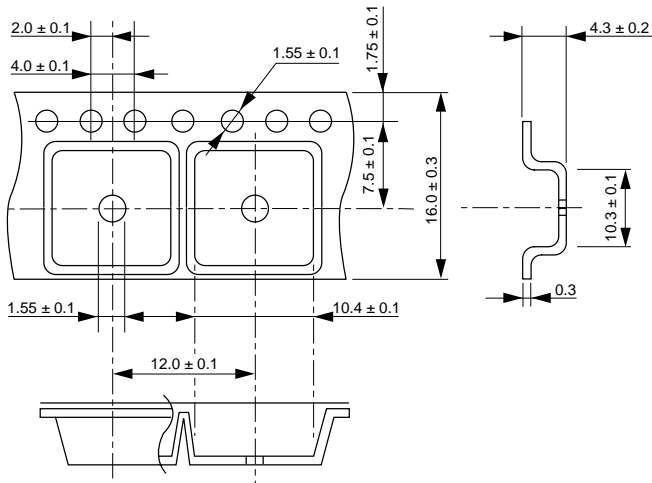

OUTLINE AND DIMENSIONS (REEL)

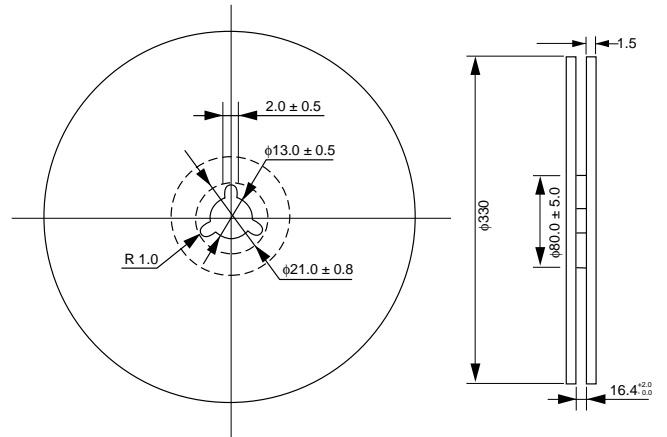

Packaging : 1000 pcs/reel

TAPING DIRECTION

PS7141L-1B-E3
PS7141L-2B-E3

PS7141L-1B-E4
PS7141L-2B-E4

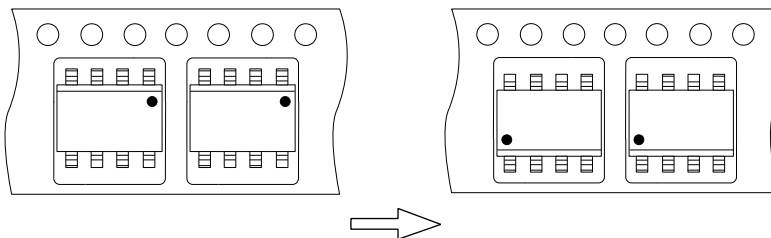

RECOMMENDED SOLDERING CONDITIONS

(1) Infrared reflow soldering

- Peak reflow temperature 235 °C or below (package surface temperature)
- Time of temperature higher than 210 °C 30 seconds or less
- Number of reflows Two
- Flux Rosin flux containing small amount of chlorine
(The flux with a maximum chlorine content of 0.2 Wt % is recommended.)

Recommended Temperature Profile of Infrared Reflow

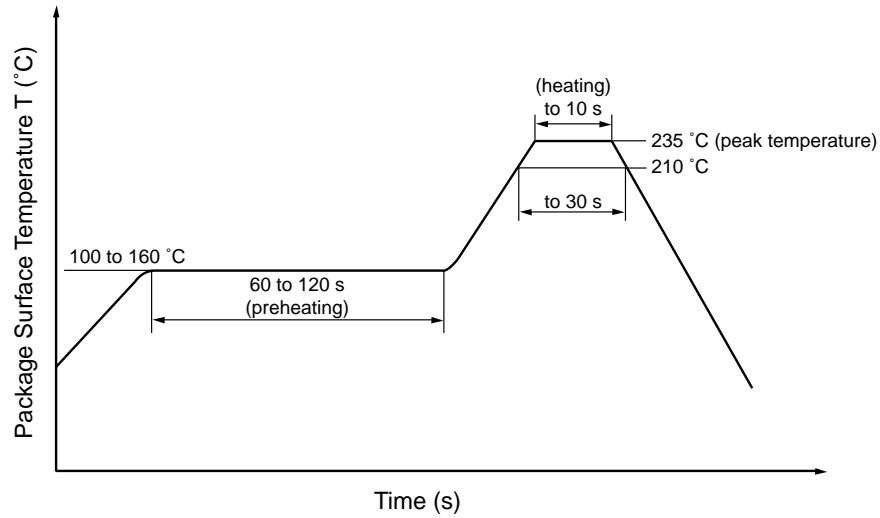

(2) Dip soldering

- Temperature 260 °C or below (molten solder temperature)
- Time 10 seconds or less
- Number of times One
- Flux Rosin flux containing small amount of chlorine
(The flux with a maximum chlorine content of 0.2 Wt % is recommended.)

(3) Cautions

- Fluxes
Avoid removing the residual flux with freon-based cleaning solvent.