



BIPOLAR ANALOG INTEGRATED CIRCUIT
 μ PC2749TB

**3 V, SUPER MINIMOLD SILICON MMIC
 WIDEBAND AMPLIFIER
 FOR MOBILE COMMUNICATIONS**

DESCRIPTION

The μ PC2749TB is a silicon monolithic integrated circuit designed as amplifier for mobile communications. This IC is packaged in super minimold package which is smaller than conventional minimold.

The μ PC2749TB has compatible pin connections and performance to μ PC2749T of conventional minimold version. So, in the case of reducing your system size, μ PC2749TB is suitable to replace from μ PC2749T.

This IC is manufactured using NEC's 20 GHz fr NESAT™ III silicon bipolar process. This process uses silicon nitride passivation film and gold electrodes. These materials can protect chip surface from external pollution and prevent corrosion/migration. Thus, this IC has excellent performance, uniformity and reliability.

FEATURES

- High-density surface mounting : 6-pin super minimold package
- Supply voltage : $V_{cc} = 2.7$ to 3.3 V
- Noise figure : NF = 4.0 dB TYP. @ $f = 1.9$ GHz
- Upper limit operating frequency : $f_u = 2.9$ GHz TYP. @ 3 dB down below from gain at $f = 0.9$ GHz

APPLICATION

- GPS receiver
- Wireless LAN

ORDERING INFORMATION

| Part Number | Package | Marking | Supplying Form |
|-------------------|----------------------|---------|--|
| μ PC2749TB-E3 | 6-pin super minimold | C1U | Embossed tape 8 mm wide. 1, 2, 3 pins face to perforation side of the tape. Qty 3 kp/reel. |

Remark To order evaluation samples, please contact your local NEC sales office. (Part number for sample order: μ PC2749TB)

Caution Electro-static sensitive devices

The information in this document is subject to change without notice. Before using this document, please confirm that this is the latest version.
 Not all devices/types available in every country. Please check with local NEC representative for availability and additional information.

PIN CONNECTIONS

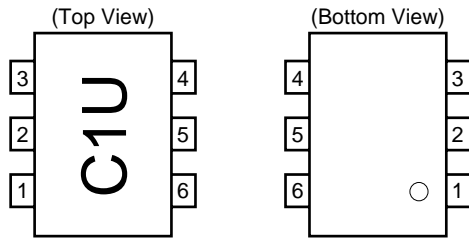

| Pin No. | Pin Name |
|---------|-----------------|
| 1 | INPUT |
| 2 | GND |
| 3 | GND |
| 4 | OUTPUT |
| 5 | GND |
| 6 | V _{CC} |

PRODUCT LINE-UP (T_A = +25°C, V_{CC} = 3.0 V, Z_L = Z_S = 50 Ω)

| Part No. | f _u (GHz) | P _{O(sat)} (dBm) | G _P (dB) | NF (dB) | I _{CC} (mA) | Package | Marking |
|-----------|-------------------------|------------------------------|------------------------|------------|-------------------------|----------------------|---------|
| μPC2749T | 2.9 | -6.0 | 16 | 4.0 | 6.0 | 6-pin minimold | C1U |
| μPC2749TB | | | | | | 6-pin super minimold | |

Remark Typical performance. Please refer to **ELECTRICAL CHARACTERISTICS** in detail.

Notice The package size distinguishes between minimold and super minimold.

SYSTEM APPLICATION EXAMPLE

EXAMPLE OF GPS RECEIVER

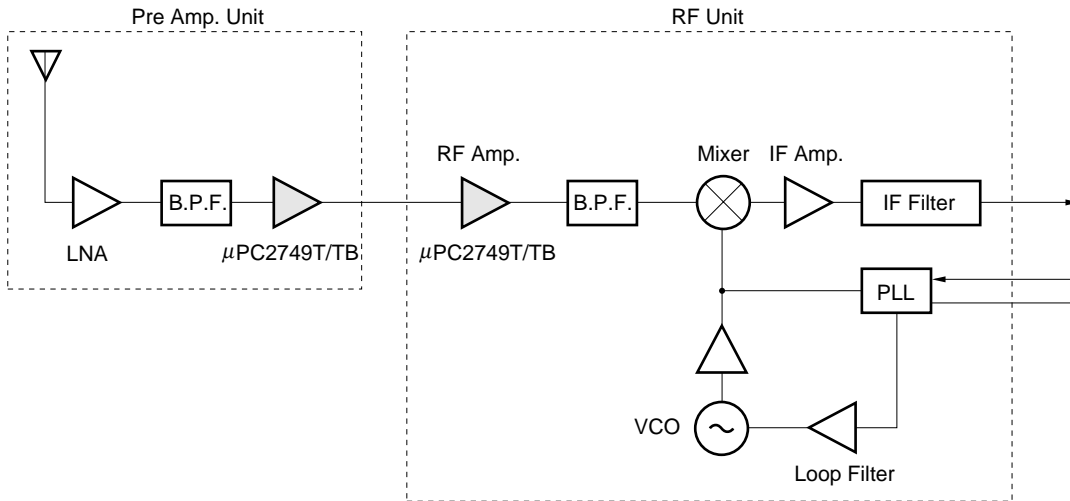

To know the associated products, please refer to each latest data sheet.

PIN EXPLANATION

| Pin No. | Pin Name | Applied Voltage (V) | Pin Voltage (V) <small>Note</small> | Function and Applications | Internal Equivalent Circuit |
|-------------|----------|---------------------|--|--|-----------------------------|
| 1 | INPUT | – | 0.82 | Signal input pin. A internal matching circuit, configured with resistors, enables 50 Ω connection over a wide band. This pin must be coupled to signal source with capacitor for DC cut. | |
| 4 | OUTPUT | – | 2.87 | Signal output pin. A internal matching circuit, configured with resistors, enables 50 Ω connection over a wide band. This pin must be coupled to next stage with capacitor for DC cut. | |
| 6 | Vcc | 2.7 to 3.3 | – | Power supply pin. This pin should be externally equipped with bypass capacity to minimize ground impedance. | |
| 2 3 5 | GND | 0 | – | Ground pin. This pin should be connected to system ground with minimum inductance. Ground pattern on the board should be formed as wide as possible. All the ground pins must be connected together with wide ground pattern to decrease impedance difference. | |

Note Pin voltage is measured at Vcc = 3.0 V.

ABSOLUTE MAXIMUM RATINGS

| Parameter | Symbol | Conditions | Ratings | Unit |
|-------------------------------|------------------|---|-------------|------|
| Supply Voltage | V _{CC} | T _A = +25 °C | 4.0 | V |
| Total Circuit Current | I _{CC} | T _A = +25 °C | 15 | mA |
| Power Dissipation | P _D | Mounted on doublesided copper clad 50 × 50 × 1.6 mm epoxy glass PWB (T _A = +85°C) | 200 | mW |
| Operating Ambient Temperature | T _A | | -40 to +85 | °C |
| Storage Temperature | T _{stg} | | -55 to +150 | °C |
| Input Power | P _{in} | T _A = +25 °C | 0 | dBm |

RECOMMENDED OPERATING CONDITIONS

| Parameter | Symbol | MIN. | TYP. | MAX. | Unit |
|-------------------------------|-----------------|------|------|------|------|
| Supply Voltage | V _{CC} | 2.7 | 3.0 | 3.3 | V |
| Operating Ambient Temperature | T _A | -40 | +25 | +85 | °C |

ELECTRICAL CHARACTERISTICS (T_A = +25 °C, V_{CC} = 3.0 V, Z_S = Z_L = 50 Ω)

| Parameter | Symbol | Test Conditions | MIN. | TYP. | MAX. | Unit |
|---------------------------------|---------------------|---|------|------|------|------|
| Circuit Current | I _{CC} | No Signal | 4.0 | 6.0 | 8.0 | mA |
| Power Gain | G _P | f = 1.9 GHz | 13.0 | 16.0 | 18.5 | dB |
| Maximum Output Level | P _{O(sat)} | f = 1.9 GHz, P _{in} = -6 dBm | -9.0 | -6.0 | - | dBm |
| Noise Figure | NF | f = 1.9 GHz | - | 4.0 | 5.5 | dB |
| Upper Limit Operating Frequency | f _u | 3 dB down below flat gain at f = 0.9 GHz | 2.5 | 2.9 | - | GHz |
| Isolation | ISL | f = 1.9 GHz | 25 | 30 | - | dB |
| Input Return Loss | RL _{in} | f = 1.9 GHz | 7 | 10 | - | dB |
| Output Return Loss | RL _{out} | f = 1.9 GHz | 9.5 | 12.5 | - | dB |

STANDARD CHARACTERISTICS FOR REFERENCE (T_A = +25 °C, V_{CC} = 3.0 V, Z_S = Z_L = 50 Ω)

| Parameter | Symbol | Test Conditions | Reference Value | Unit |
|--------------------------------------|----------------------|--|-----------------|------|
| Power Gain | G _P | f = 0.9 GHz | 14.5 | dB |
| Noise Figure | NF | f = 0.9 GHz | 3.2 | dB |
| 3rd Order Intermodulation Distortion | IM ₃ | P _{out} = -20 dBm f ₁ = 1.900 GHz, f ₂ = 1.902 GHz | -33 | dBc |
| Gain 1 dB Compression Output Level | P _{O(1 dB)} | f = 1.9 GHz | -12.5 | dBm |

TEST CIRCUIT

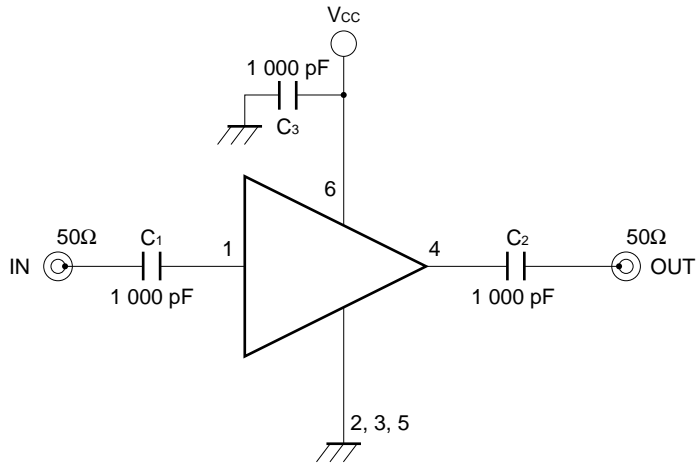

EXAMPLE OF APPLICATION CIRCUIT

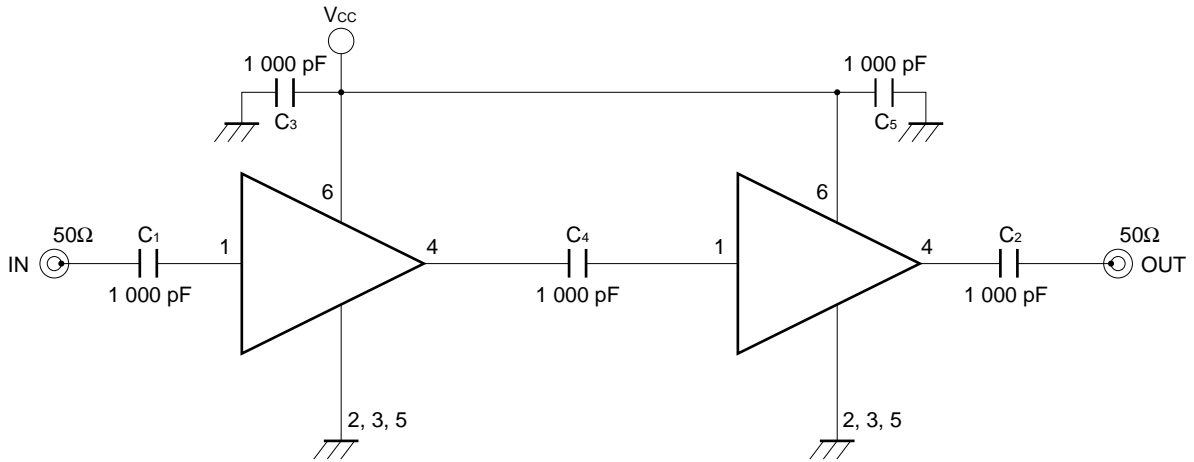

The application circuits and their parameters are for reference only and are not intended for use in actual design-ins.

CAPACITORS FOR THE V_{CC}, INPUT AND OUTPUT PINS

1 000 pF capacitors are recommendable as bypass capacitor for V_{CC} pin and coupling capacitors for input/output pins.

Bypass capacitor for V_{CC} pin is intended to minimize V_{CC} pin's ground impedance. Therefore, stable bias can be supplied against V_{CC} fluctuation.

Coupling capacitors for input/output pins are intended to minimize RF serial impedance and cut DC.

To get a flat gain from 100 MHz up, 1 000 pF capacitors are assembled on the test circuit. [Actually, 1 000 pF capacitors give flat gain at least 10 MHz. In the case of under 10 MHz operation, increase the value of coupling capacitor such as 2 200 pF. Because the coupling capacitors are determined by the equation of $C = 1/(2 \pi fZ_s)$.]

ILLUSTRATION OF THE TEST CIRCUIT ASSEMBLED ON EVALUATION BOARD

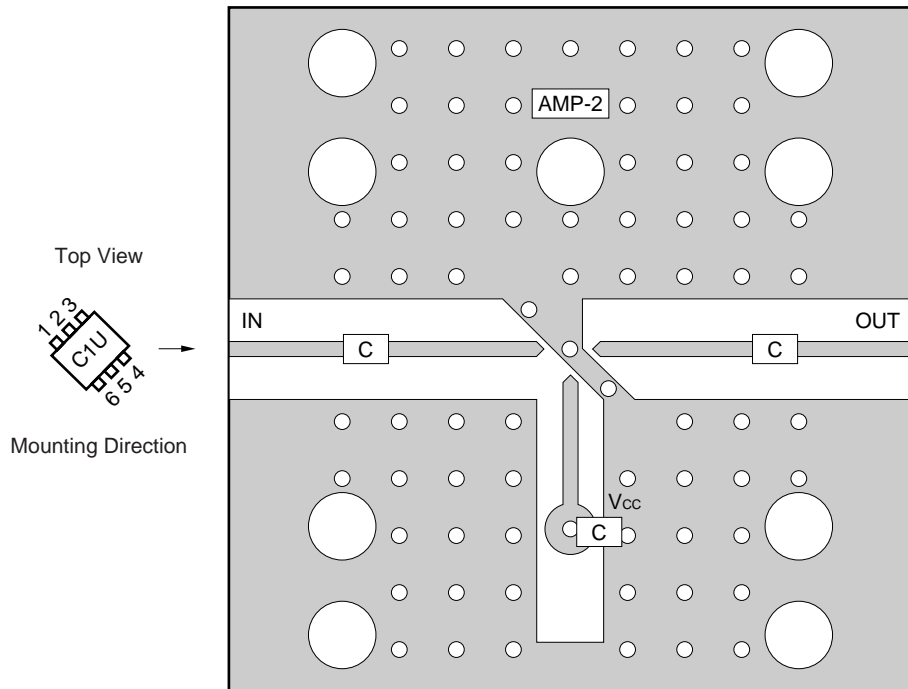

COMPONENT LIST

| | Value |
|---|----------|
| C | 1 000 pF |

Notes

1. 30 × 30 × 0.4 mm double sided copper clad polyimide board.
2. Back side: GND pattern
3. Solder plated on pattern
4. ○ ○ : Through holes

For more information on the use of this IC, refer to the following application note: USAGE AND APPLICATIONS OF 6-PIN MINI-MOLD, 6-PIN SUPER MINI-MOLD SILICON HIGH-FREQUENCY WIDEBAND AMPLIFIER MMIC (P11976E).

★ TYPICAL CHARACTERISTICS (Unless otherwise specified, $T_A = +25\text{ }^\circ\text{C}$)

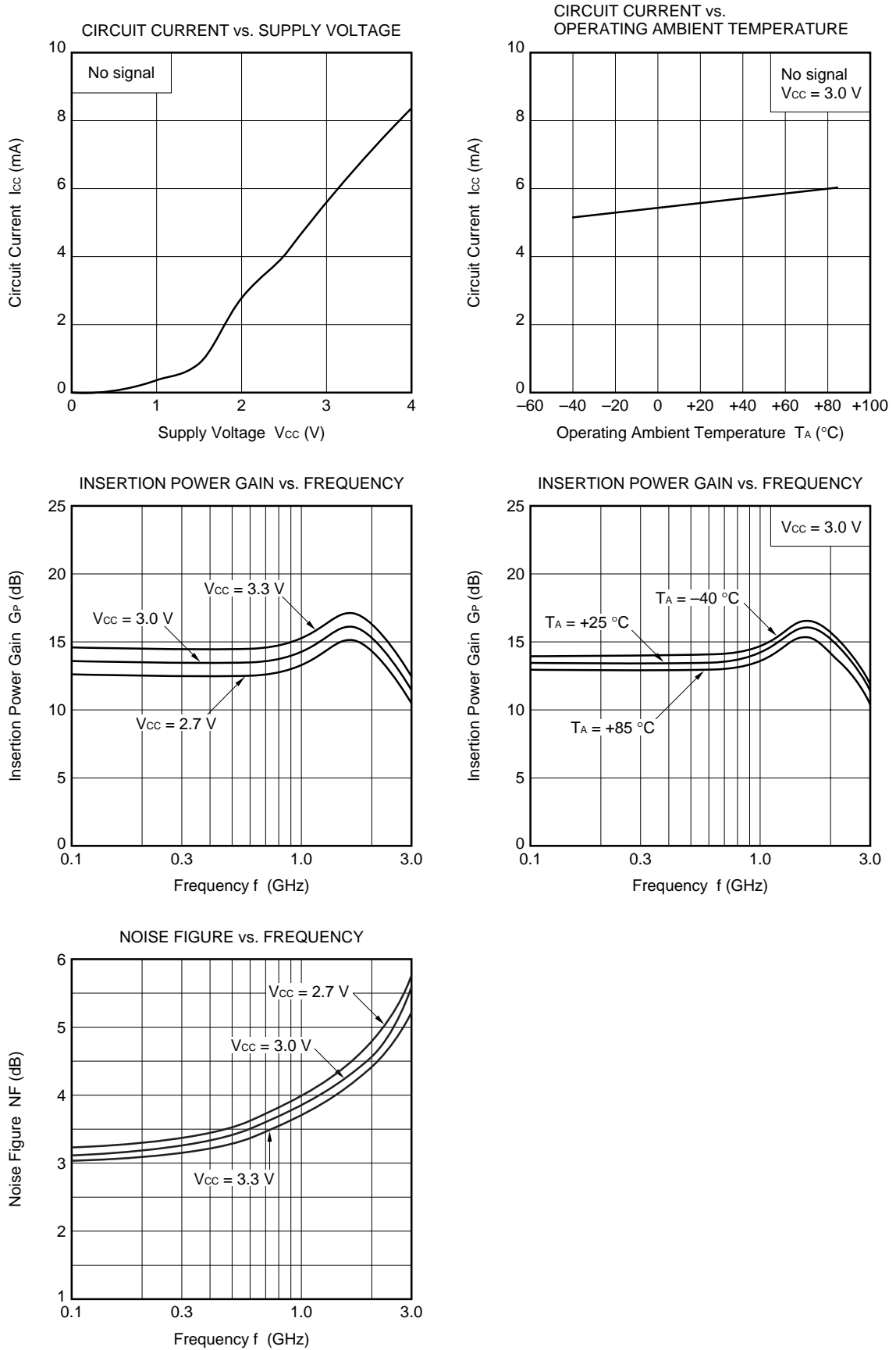

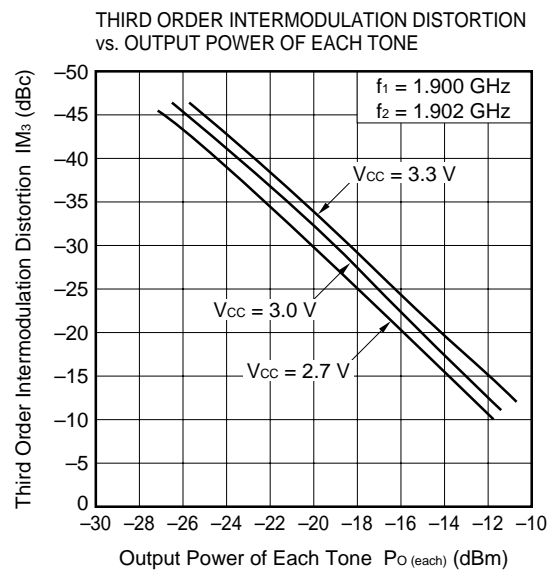
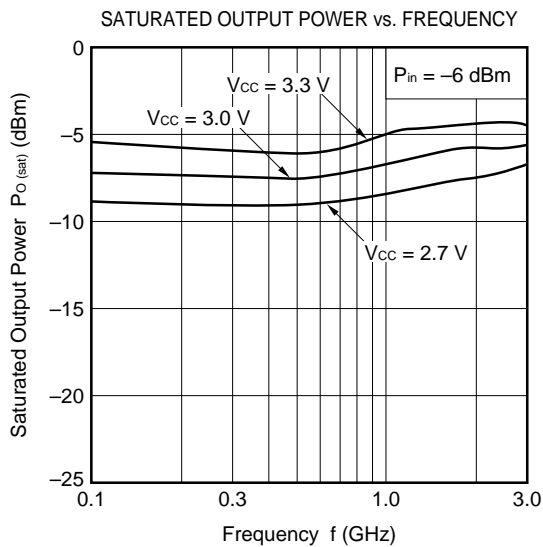
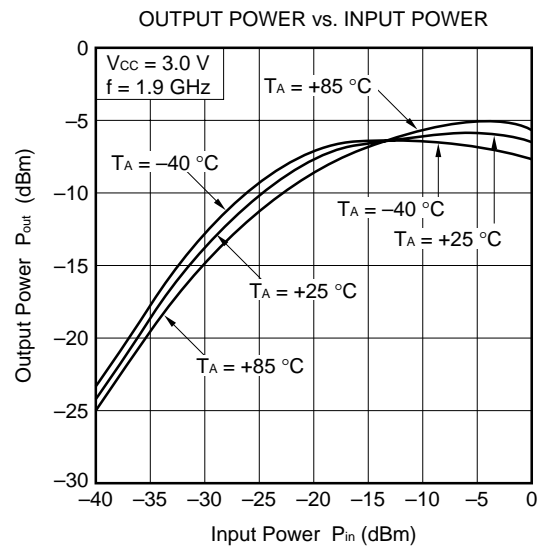
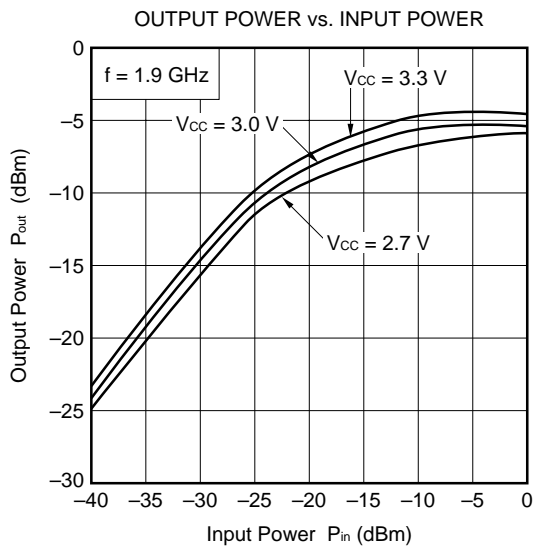
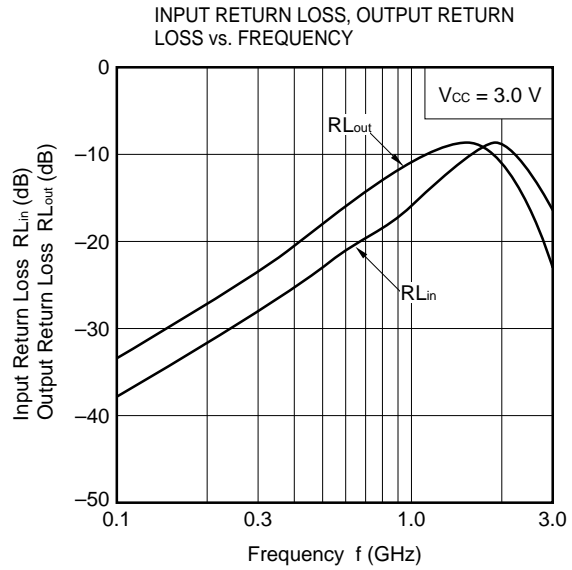
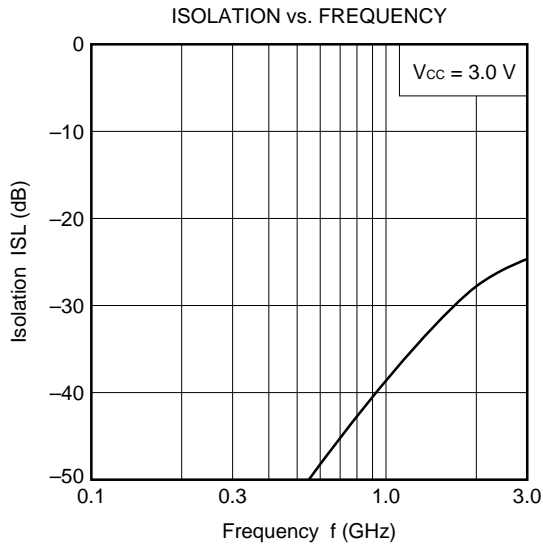

★ S-PARAMETER ($T_A = +25\text{ }^\circ\text{C}$, $V_{CC} = 3.0\text{ V}$)

S₁₁-FREQUENCY

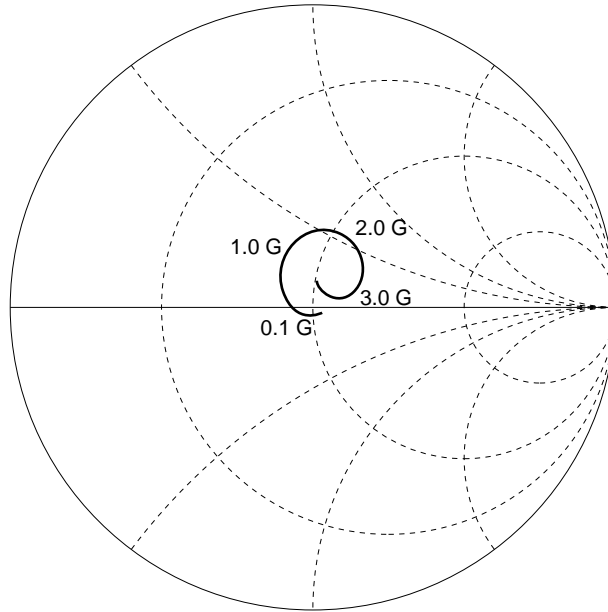

S₂₂-FREQUENCY

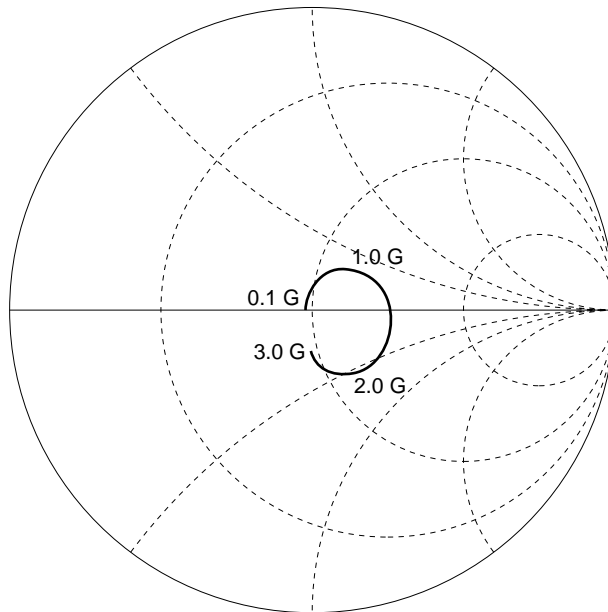

TYPICAL S-PARAMETER VALUES (T_A = +25 °C)

μPC2749TB

V_{CC} = 3.0 V, I_{CC} = 6.5 mA

| FREQUENCY MHz | S ₁₁ | | S ₂₁ | | S ₁₂ | | S ₂₂ | | K |
|------------------|-----------------|--------|-----------------|--------|-----------------|-------|-----------------|-------|--------|
| | MAG | ANG | MAG | ANG | MAG | ANG | MAG | ANG | |
| 100.0000 | 0.021 | 13.0 | 4.096 | -1.9 | 0.002 | -1.1 | 0.024 | 165.8 | 66.82 |
| 200.0000 | 0.038 | -30.5 | 4.216 | -7.8 | 0.001 | 75.4 | 0.033 | 113.6 | 129.26 |
| 300.0000 | 0.034 | -71.8 | 4.282 | -15.5 | 0.001 | 141.5 | 0.064 | 96.1 | 90.16 |
| 400.0000 | 0.052 | -120.5 | 4.403 | -21.0 | 0.002 | 129.9 | 0.080 | 87.9 | 45.30 |
| 500.0000 | 0.062 | -149.9 | 4.390 | -26.6 | 0.002 | 134.1 | 0.103 | 76.9 | 57.58 |
| 600.0000 | 0.079 | -169.7 | 4.399 | -31.6 | 0.003 | 128.3 | 0.127 | 68.6 | 34.08 |
| 700.0000 | 0.097 | 173.6 | 4.566 | -36.7 | 0.005 | 132.9 | 0.151 | 60.6 | 22.08 |
| 800.0000 | 0.116 | 160.5 | 4.667 | -41.3 | 0.007 | 131.5 | 0.174 | 53.7 | 14.70 |
| 900.0000 | 0.134 | 149.3 | 4.843 | -46.8 | 0.008 | 129.3 | 0.197 | 44.9 | 12.29 |
| 1000.0000 | 0.156 | 138.8 | 5.016 | -52.6 | 0.009 | 124.6 | 0.220 | 36.1 | 10.00 |
| 1100.0000 | 0.178 | 128.5 | 5.305 | -60.3 | 0.014 | 131.4 | 0.240 | 28.0 | 6.15 |
| 1200.0000 | 0.195 | 118.7 | 5.660 | -67.1 | 0.016 | 122.5 | 0.262 | 17.3 | 5.13 |
| 1300.0000 | 0.214 | 108.7 | 5.835 | -76.2 | 0.020 | 118.6 | 0.279 | 8.6 | 3.80 |
| 1400.0000 | 0.229 | 99.5 | 6.148 | -84.5 | 0.022 | 114.4 | 0.287 | -2.0 | 3.23 |
| 1500.0000 | 0.249 | 89.4 | 6.364 | -93.8 | 0.025 | 107.7 | 0.294 | -13.5 | 2.72 |
| 1600.0000 | 0.259 | 79.9 | 6.611 | -103.6 | 0.028 | 104.3 | 0.294 | -23.6 | 2.35 |
| 1700.0000 | 0.264 | 69.8 | 6.577 | -113.5 | 0.032 | 96.8 | 0.283 | -33.8 | 2.09 |
| 1800.0000 | 0.259 | 60.3 | 6.549 | -123.4 | 0.034 | 91.8 | 0.272 | -44.1 | 1.99 |
| 1900.0000 | 0.248 | 50.9 | 6.407 | -132.9 | 0.036 | 83.3 | 0.256 | -53.8 | 1.97 |
| 2000.0000 | 0.238 | 43.6 | 6.321 | -140.8 | 0.037 | 78.5 | 0.234 | -61.4 | 1.99 |
| 2100.0000 | 0.218 | 35.9 | 6.046 | -148.8 | 0.038 | 75.1 | 0.213 | -69.5 | 2.04 |
| 2200.0000 | 0.204 | 30.1 | 5.862 | -156.5 | 0.039 | 70.4 | 0.193 | -73.8 | 2.08 |
| 2300.0000 | 0.183 | 25.3 | 5.696 | -163.2 | 0.040 | 68.3 | 0.174 | -79.5 | 2.15 |
| 2400.0000 | 0.156 | 21.2 | 5.430 | -170.5 | 0.041 | 60.7 | 0.164 | -84.1 | 2.25 |
| 2500.0000 | 0.140 | 18.8 | 5.282 | -176.3 | 0.042 | 61.6 | 0.152 | -82.1 | 2.25 |
| 2600.0000 | 0.119 | 18.7 | 5.013 | 177.2 | 0.040 | 58.1 | 0.142 | -84.5 | 2.53 |
| 2700.0000 | 0.095 | 21.2 | 4.849 | 170.9 | 0.042 | 55.1 | 0.146 | -85.5 | 2.46 |
| 2800.0000 | 0.078 | 30.0 | 4.596 | 164.9 | 0.042 | 51.9 | 0.149 | -83.9 | 2.62 |
| 2900.0000 | 0.066 | 44.5 | 4.446 | 158.1 | 0.042 | 44.7 | 0.154 | -91.8 | 2.70 |
| 3000.0000 | 0.070 | 66.0 | 4.163 | 152.3 | 0.044 | 41.9 | 0.171 | -92.8 | 2.73 |
| 3100.0000 | 0.082 | 78.1 | 3.966 | 145.3 | 0.042 | 37.1 | 0.181 | -99.6 | 2.97 |

PACAGE DIMENSIONS

6 pin super minimold (Unit: mm)

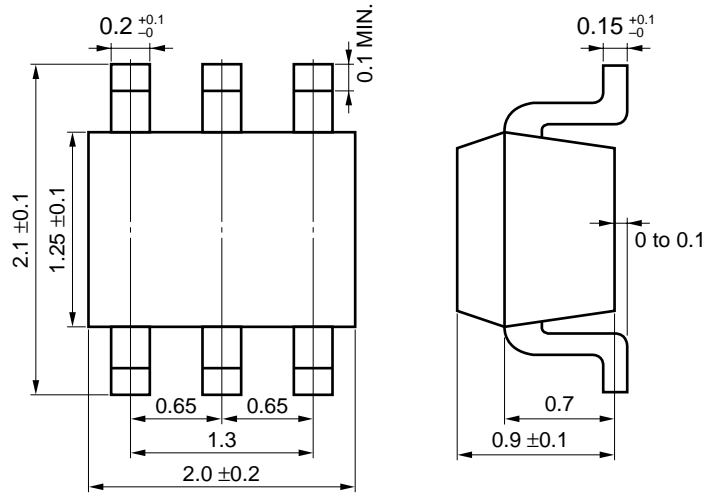

NOTES ON CORRECT USE

- (1) Observe precautions for handling because of electro-static sensitive devices.
- (2) Form a ground pattern as wide as possible to minimize ground impedance (to prevent undesired oscillation).
All the ground pins must be connected together with wide ground pattern to decrease impedance difference.
- (3) The bypass capacitor should be attached to Vcc line.
- (4) The DC cut capacitor must be attached to input pin.

RECOMMENDED SOLDERING CONDITIONS

This product should be soldered under the following recommended conditions. For soldering methods and conditions other than those recommended below, contact your NEC sales representative.

| Soldering Method | Soldering Conditions | Recommended Condition Symbol |
|------------------|---|------------------------------|
| Infrared Reflow | Package peak temperature: 235 °C or below Time: 30 seconds or less (at 210 °C) Count: 3, Exposure limit: None ^{Note} | IR35-00-3 |
| VPS | Package peak temperature: 215 °C or below Time: 40 seconds or less (at 200 °C) Count: 3, Exposure limit: None ^{Note} | VP15-00-3 |
| Wave Soldering | Soldering bath temperature: 260 °C or below Time: 10 seconds or less Count: 1, Exposure limit: None ^{Note} | WS60-00-1 |
| Partial Heating | Pin temperature: 300 °C Time: 3 seconds or less (per side of device) Exposure limit: None ^{Note} | — |

Note After opening the dry pack, keep it in a place below 25 °C and 65 % RH for the allowable storage period.

Caution Do not use different soldering methods together (except for partial heating).

For details of recommended soldering conditions for surface mounting, refer to information document SEMICONDUCTOR DEVICE MOUNTING TECHNOLOGY MANUAL (C10535E).

[MEMO]

[MEMO]

[MEMO]

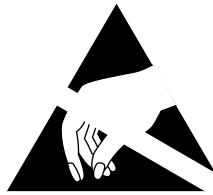

ATTENTION

OBSERVE PRECAUTIONS
FOR HANDLING
ELECTROSTATIC
SENSITIVE
DEVICES

NESAT (NEC Silicon Advanced Technology) is a trademark of NEC Corporation.

- **The information in this document is subject to change without notice. Before using this document, please confirm that this is the latest version.**
 - No part of this document may be copied or reproduced in any form or by any means without the prior written consent of NEC Corporation. NEC Corporation assumes no responsibility for any errors which may appear in this document.
 - NEC Corporation does not assume any liability for infringement of patents, copyrights or other intellectual property rights of third parties by or arising from use of a device described herein or any other liability arising from use of such device. No license, either express, implied or otherwise, is granted under any patents, copyrights or other intellectual property rights of NEC Corporation or others.
 - Descriptions of circuits, software, and other related information in this document are provided for illustrative purposes in semiconductor product operation and application examples. The incorporation of these circuits, software, and information in the design of the customer's equipment shall be done under the full responsibility of the customer. NEC Corporation assumes no responsibility for any losses incurred by the customer or third parties arising from the use of these circuits, software, and information.
 - While NEC Corporation has been making continuous effort to enhance the reliability of its semiconductor devices, the possibility of defects cannot be eliminated entirely. To minimize risks of damage or injury to persons or property arising from a defect in an NEC semiconductor device, customers must incorporate sufficient safety measures in its design, such as redundancy, fire-containment, and anti-failure features.
 - NEC devices are classified into the following three quality grades:
"Standard", "Special", and "Specific". The Specific quality grade applies only to devices developed based on a customer designated "quality assurance program" for a specific application. The recommended applications of a device depend on its quality grade, as indicated below. Customers must check the quality grade of each device before using it in a particular application.
 - Standard: Computers, office equipment, communications equipment, test and measurement equipment, audio and visual equipment, home electronic appliances, machine tools, personal electronic equipment and industrial robots
 - Special: Transportation equipment (automobiles, trains, ships, etc.), traffic control systems, anti-disaster systems, anti-crime systems, safety equipment and medical equipment (not specifically designed for life support)
 - Specific: Aircraft, aerospace equipment, submersible repeaters, nuclear reactor control systems, life support systems or medical equipment for life support, etc.
- The quality grade of NEC devices is "Standard" unless otherwise specified in NEC's Data Sheets or Data Books. If customers intend to use NEC devices for applications other than those specified for Standard quality grade, they should contact an NEC sales representative in advance.