

TOSHIBA CMOS DIGITAL INTEGRATED CIRCUIT SILICON MONOLITHIC

# TMPN3120B1AM

Neuron<sup>®</sup> Chip  
For Distributed Intelligent Control Networks (LONWORKS<sup>®</sup>)

The TMPN3120B1AM is a Neuron Chip which configures LONWORKS nodes on a single chip. Neuron Chips have all the built-in communications and control functions required to implement LONWORKS nodes. These nodes may then be easily integrated into highly-reliable distributed intelligent control networks. The typical functions for this chip are explained below.

## FEATURES

- I / O Functions
  - Eleven programmable I / O pins.
  - Two programmable 16-bit timers and counters built in.
  - 34 different types of I / O functions to handle a wide range of input and output.
  - ROM firmware image containing pre-programmed I / O drivers, greatly simplifying application programs.
- Network functions
  - Two CPUs for communication protocol processing built in. The communications and application CPUs execute in parallel.
  - Equipped with a built-in LonTalk protocol which supports all seven levels of the OSI reference model with ISO.
  - The ROM firmware image contains a complete network operating system, greatly simplifying application programs.
  - Built-in twisted-pair wire transceiver
  - Equipped with communications modes and communication speeds which support various types of external transceivers. Supports twisted-pair wire, power line, radio ( RF ), infrared, coaxial cables, and fiber optics.
  - Communication port transceiver modes and logical addresses stored within the EEPROM. Can be amended via the network.

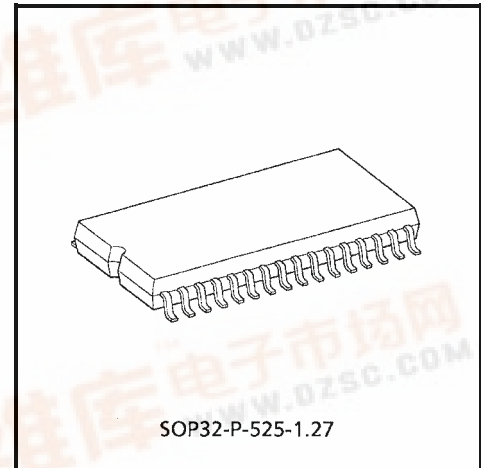

Weight : 1.1g (Typ.)

000707EBA1

● TOSHIBA is continually working to improve the quality and reliability of its products. Nevertheless, semiconductor devices in general can malfunction or fail due to their inherent electrical sensitivity and vulnerability to physical stress. It is the responsibility of the buyer, when utilizing TOSHIBA products, to comply with the standards of safety in making a safe design for the entire system, and to avoid situations in which a malfunction or failure of such TOSHIBA products could cause loss of human life, bodily injury or damage to property. In developing your designs, please ensure that TOSHIBA products are used within specified operating ranges as set forth in the most recent TOSHIBA products specifications. Also, please keep in mind the precautions and conditions set forth in the "Handling Guide for Semiconductor Devices," or "TOSHIBA Semiconductor Reliability Handbook" etc..

● The TOSHIBA products listed in this document are intended for usage in general electronics applications (computer, personal equipment, office equipment, measuring equipment, industrial robotics, domestic appliances, etc.). These TOSHIBA products are neither intended nor warranted for usage in equipment that requires extraordinarily high quality and/or reliability or a malfunction or failure of which may cause loss of human life or bodily injury ("Unintended Usage"). Unintended Usage include atomic energy control instruments, airplane or spaceship instruments, transportation instruments, traffic signal instruments, combustion control instruments, medical instruments, all types of safety devices, etc.. Unintended Usage of TOSHIBA products listed in this document shall be made at the customer's own risk.

● The products described in this document are subject to the foreign exchange and foreign trade laws.

● The information contained herein is presented only as a guide for the applications of our products. No responsibility is assumed by TOSHIBA CORPORATION for any infringements of intellectual property or other rights of the third parties which may result from its use. No license is granted by implication or otherwise under any intellectual property or other rights of TOSHIBA CORPORATION or others.

● The information contained herein is subject to change without notice.



- Other functions
  - Application programs are also stored within the EEPROM.  
Can be updated by downloading over the network. Up to 400-byte applications can be stored.
  - Built-in watch-dog timer.
  - Each chip has a unique ID number.  
Effective during the logical installation of networks.
  - Low electrical consumption mode supported with a sleep mode.
  - Built-in low-voltage detection circuit.  
Prevents incorrect operations and writing errors in the EEPROM during drops in power voltage.
  - The package is SOP32-P-525-1.27.

**BLOCK DIAGRAM**

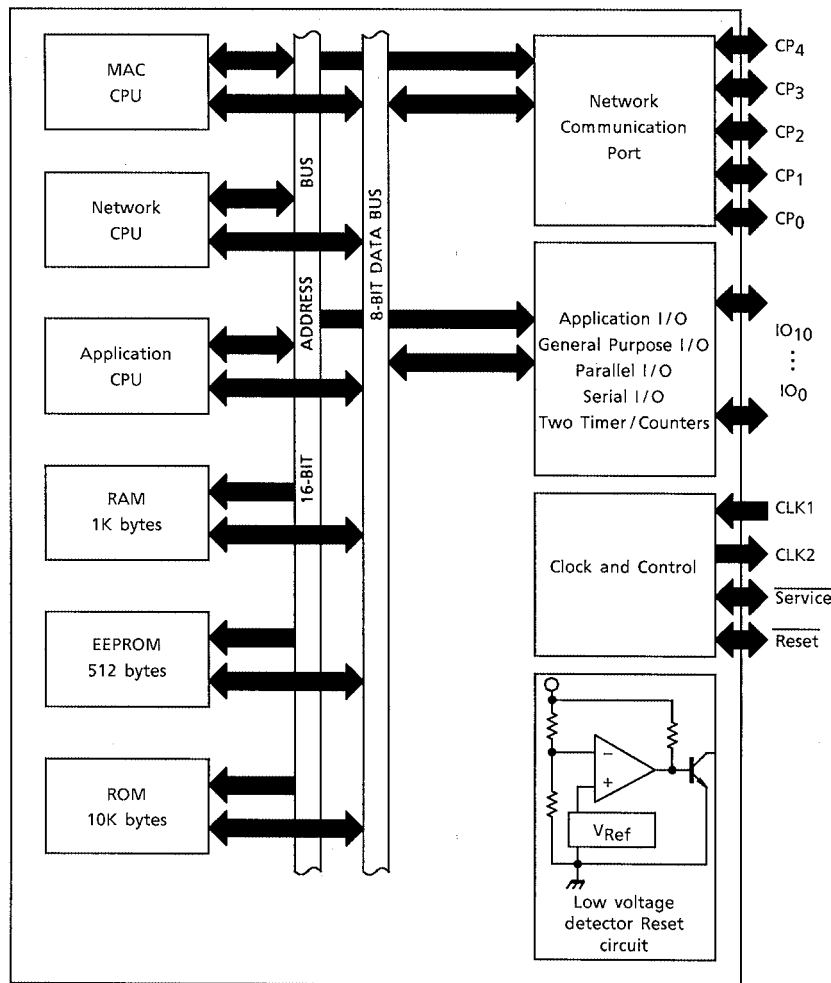

ITEM	TMPN3120B1AM
CPU	8-bit CPU×3
RAM	1,024 bytes
ROM	10,240 bytes
EEPROM	512 bytes
16-bit Timer / Counter	2 channels
External Memory Interface	Not available
Package	32-pin SOP

## PIN ASSIGNMENT

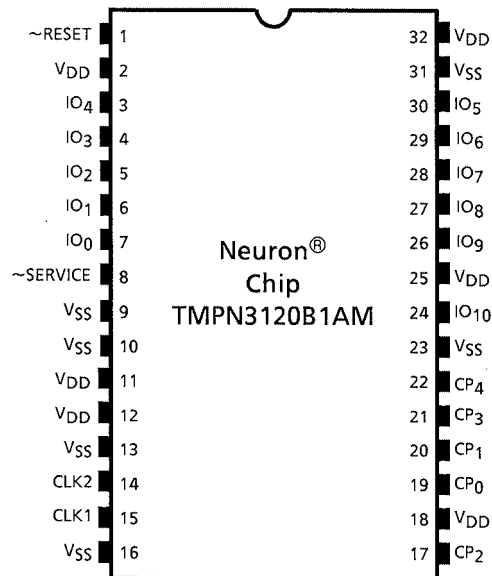

## PIN FUNCTION

PIN No.	PIN NAME	I / O	PIN FUNCTION
15	CLK1	Input	Oscillator connection, or external clock input.
14	CLK2	Output	Oscillator connection. Leave open when external clock is input to CLK1.
1	~RESET	I / O (built-in configurable pull-up)	Reset pin. (Active low)
8	~SERVICE	I / O (built-in configurable pull-up)	Service pin. Indicator output during operation.
7~4	IO <sub>0</sub> ~IO <sub>3</sub>	I / O	Large current sink capacity (20mA). General I / O port.
3, 30~28	IO <sub>4</sub> ~IO <sub>7</sub>	I / O (built-in configurable pull-up)	General I / O port. One of IO <sub>4</sub> to IO <sub>7</sub> can be specified as No.1 timer / counter input. Output signal can be output to IO <sub>0</sub> . IO <sub>4</sub> can be used as the No.2 timer / counter input with IO <sub>1</sub> as output.
27, 26, 24	IO <sub>8</sub> ~IO <sub>10</sub>	I / O	General I / O port. Can be used for serial communication with other device.
2, 11, 12, 18, 25, 32	V <sub>DD</sub>	Input	Power input (5.0V Typ.)
9, 10, 13, 16, 23, 31	V <sub>SS</sub>	Input	Power input (0V GND)
19, 20, 17, 21, 22	CP <sub>0</sub> ~CP <sub>4</sub>	I / O	Bidirectional port for communications. Supports several communications protocols by specifying mode.

- \* :
- The ~SERVICE and IO<sub>4</sub> to IO<sub>7</sub> terminals are programmable pull-ups.
  - All V<sub>DD</sub> terminals must be externally connected.
  - All V<sub>SS</sub> terminals must be externally connected.

## MAXIMUM RATINGS ( $V_{SS} = 0V$ , $V_{SS}$ typ.)

CHARACTERISTICS	SYMBOL	RATING	UNIT
Power Supply Voltage	$V_{DD}$	-0.3~7.0	V
Input Voltage	$V_{IN}$	-0.3~ $V_{DD}+0.3$	V
Power Dissipation	PD	800	mW
Storage Temperature	$T_{stg}$	-65~150	°C

## OPERATING CONDITIONS

ITEM	SYMBOL	MIN	TYP.	MAX	UNIT
Operating Voltage	$V_{DD}$	4.5	5.0	5.5	V
Input Voltage ( TTL )	$V_{IH}$	2.0	—	$V_{DD}$	V
	$V_{IL}$	$V_{SS}$	—	0.8	V
Input Voltage ( CMOS )	$V_{IH}$	$V_{DD}-0.8$	—	$V_{DD}$	V
	$V_{IL}$	$V_{SS}$	—	0.8	V
Operating Frequency	$f_{osc}$	0.625	—	10	MHz
Operating Temperature	$T_{opr}$	-40	—	85	°C

## ELECTRICAL CHARACTERISTICS

DC characteristic (  $V_{DD} = 5.0 V \pm 10%$ ,  $V_{SS} = 0 V$ ,  $T_a = -40 \sim 85^\circ C$  )

( Above operating conditions apply unless otherwise states. )

CHARACTERISTICS	SYMBOL	PINS	TEST CONDITION	MIN	MAX	UNIT	
LOW Output Voltage (1)	$V_{OL}$ (1)	$IO_0 \sim IO_3$	$I_{OL}=20mA$	0	0.8	V	
			$I_{OL}=10mA$	0	0.4	V	
LOW Output Voltage (2)	$V_{OL}$ (2)	~SERVICE	Duty cycle=50%	$I_{OL}=20mA$	0	0.8	V
				$I_{OL}=10mA$	0	0.4	V
LOW Output Voltage (3)	$V_{OL}$ (3)	CP <sub>2</sub> , CP <sub>3</sub>	$I_{OL}=40mA$	0	1.0	V	
LOW Output Voltage (4)	$V_{OL}$ (4)	Others (Note 1)	$I_{OL}=1.4mA$	0	0.4	V	
HIGH Output Voltage (1)	$V_{OH}$ (1)	$IO_0 \sim IO_3$	$I_{OH}=-1.4mA$	$V_{DD}-0.4$	$V_{DD}$	V	
HIGH Output Voltage (2)	$V_{OH}$ (2)	~SERVICE	$I_{OH}=-1.4mA$	$V_{DD}-0.4$	$V_{DD}$	V	
HIGH Output Voltage (3)	$V_{OH}$ (3)	CP <sub>2</sub> , CP <sub>3</sub>	$I_{OH}=-40mA$	$V_{DD}-1.0$	$V_{DD}$	V	
HIGH Output Voltage (4)	$V_{OH}$ (4)	Others (Note 1)	$I_{OH}=-1.4mA$	$V_{DD}-0.4$	$V_{DD}$	V	
Input Current	$I_{IN}$	(Note 2)	$V_{IN}=V_{SS} \sim V_{DD}$	-10	+10	μA	
Pull-up Current	$I_{PU}$	$IO_4 \sim IO_7$ ~SERVICE, ~RESET (Note 3)	$V_{IN}=0V$	-30	-300	μA	
Low-voltage Detection Level	$V_{LVD}$	$V_{DD}$	—	3.8	4.5	V	

Note1 : Output voltage characteristics exclude the ~RESET pin and CLK2 pin.

Note2 : Excludes pull-up input pins.

Note3 : The  $IO_4$  to  $IO_7$  and ~SERVICE pins have programmable pull-ups. ~RESET has a fixed pull-up.

ITEM		SYMBOL	TYP.	MAX	UNIT
Operating Mode Current Consumption	10 MHz Clock	$I_{DD} (OP)$	17	30	mA
	5 MHz Clock		9	15	
	2.5 MHz Clock		6	8	
	1.25 MHz Clock		4	5	
	0.625 MHz Clock		2	3	
Sleep Mode Current Consumption		$I_{DD} (SLP)$	16	100	$\mu A$

Note: Test conditions for current dissipation

$V_{DD}=5V$ , all output=with no load, all input=0.2V or below or  $V_{DD}-0.2V$ , programmable pull-up=off, crystal oscillator clock input, differential receiver disabled.

The current value ( typ. ) is a typical value when  $T_a=25^{\circ}C$

The current value ( max ) applies to the rated temperature range at  $V_{DD}=5.5V$ .

200 $\mu A$  ( typ. ) to 600 $\mu A$  ( max ) is added to the current of the differential receiver when the receiver is enabled.

The differential receiver is enabled by either of the following conditions :

- When the Neuron chip is in Run mode and the communication ports are in Differential mode.
- When the Neuron chip is in Sleep mode, the communication ports are in Differential mode, and the Comm Port Wakeup is not masked.

- Echelon, Neuron, LON, LonTalk, LonBuilder, NodeBuilder, LONWORKS, 3150, 3120 and LonManager are the registered trade marks of America's Echelon Inc.
- The Neuron Chip is manufactured by Toshiba under license from Echelon Corporation, USA. A licensing agreement between the customer and Echelon Corporation must be concluded before purchasing any of the neuron chip products.
- The Neuron chip itself does not include the I<sup>2</sup>C object function. You need the "I<sup>2</sup>C Library" delivered by Echelon.

The Neuron chip and the I<sup>2</sup>C Library do not convey nor imply a right under any I<sup>2</sup>C patent rights of Philips Electronics N.V. ("Philips") to make, use or sell any product employing such patent rights. Please refer all questions with respect to I<sup>2</sup>C patents and licenses to Philips at:

Mr. Gert-Jan Hessenlmann  
Corporate Intellectual Property  
Philips International B.V.  
Prof. Holstlaan 6  
Building WAH 1-100  
P.O. Box 220  
5600 AE, Eindhoven, The Netherlands  
Phone : +31 40 274 32 61  
Fax : +31 40 274 34 89  
E-mail: Gert.Jan.Hesselmann@philips.com.

**PACKAGE DIMENSIONS**

SOP32-P-525-1.27

Unit : mm

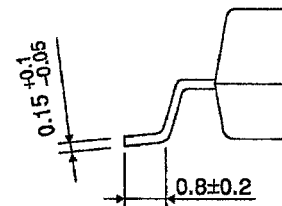
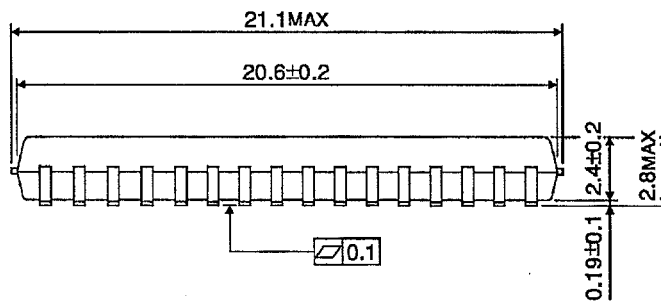
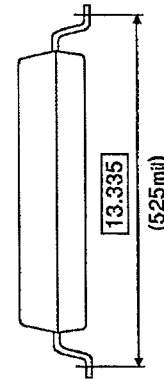
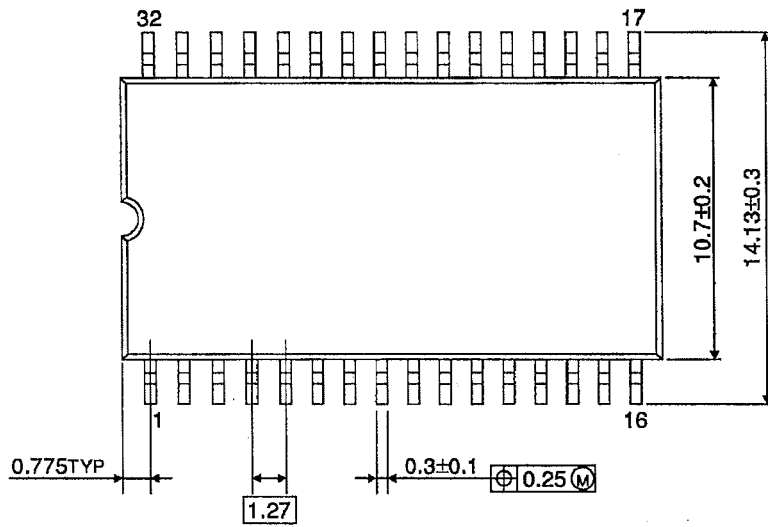

Weight : 1.0g (Typ.)