

SIEMENS

Silicon Variable Capacitance Diode

BB 419

- For VHF tuned circuit applications

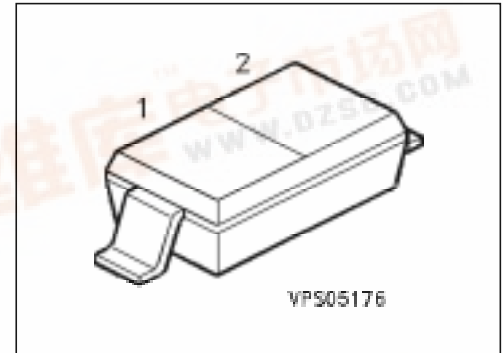

Type	Marking	Ordering Code (tape and reel)	Pin Configuration	Package ¹⁾
BB 419	white 2	Q62702-B499		SOD-123

Maximum Ratings

Parameter	Symbol	Values	Unit
Reverse voltage	V_R	28	V
Peak reverse voltage	V_{RM}	30	
Forward current, $T_A \leq 60 \text{ }^\circ\text{C}$	I_F	20	mA
Operating temperature range	T_{op}	- 55 ... + 125	$^\circ\text{C}$
Storage temperature range	T_{stg}	- 55 ... + 150	

Thermal Resistance

Junction - ambient	$R_{th JA}$	≤ 450	K/W
--------------------	-------------	------------	-----



Electrical Characteristics

at $T_A = 25\text{ °C}$, unless otherwise specified.

Parameter	Symbol	Values			Unit
		min.	typ.	max.	
Reverse current $V_R = 28\text{ V}$ $V_R = 28\text{ V}, T_A = 60\text{ °C}$	I_R	– –	– –	20 200	nA
Diode capacitance, $f = 1\text{ MHz}$ $V_R = 3\text{ V}$ $V_R = 25\text{ V}$	C_T	26 4.3	– –	32 6	pF
Capacitance ratio $f = 1\text{ MHz}, V_R = 3\text{ V}, 25\text{ V}$	C_{T3} / C_{T25}	5	–	6.5	–
Capacitance matching $V_R = 3\text{ V} \dots 25\text{ V}$	$\Delta C_T / C_T$	–	–	3	%
Series resistance $f = 100\text{ MHz}, C_T = 12\text{ pF}$	r_s	–	0.35	0.5	Ω
Figure of merit $f = 50\text{ MHz}, V_R = 3\text{ V}$ $f = 200\text{ MHz}, V_R = 25\text{ V}$	Q	–	280 600	–	–

Diode capacitance $C_T = f(V_R)$

