

Linear IC Converter

CMOS

D/A Converter for Digital Tuning (24-channel, 8-bit, on-chip OP amp)

MB88345

DESCRIPTION

The MB88345 incorporates twenty-four 8-bit D/A converter modules.

It also contains an output amplifier, allowing driving at large current.

Since the inputs data in serial mode, it requires only three control lines for data input and can be cascaded.

The MB88345 is suitable for applications such as electronic volume controls and replacement of semi-fixed resistors in tuning systems.

FEATURES

- Ultra-low power consumption (1.1 mW/ch : typical)
- Compact space-saving package (QFP-32)
- Contains 24-channel R-2R type 8-bit D/A converter
- On-chip analog output amps (sink current max. 1.0 mA, source current max. 1.0 mA)
- Analog output range : 0 V to Vcc
- Two separate power supply/ground lines for MCU interface block/operational amplifier output buffer block and D/A converter block
- Serial data input : maximum operating speed 2.5 MHz
- CMOS process

PACKAGE

32-pin Plastic QFP

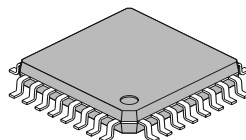

(FPT-32P-M21)

MB88345

■ PIN ASSIGNMENT

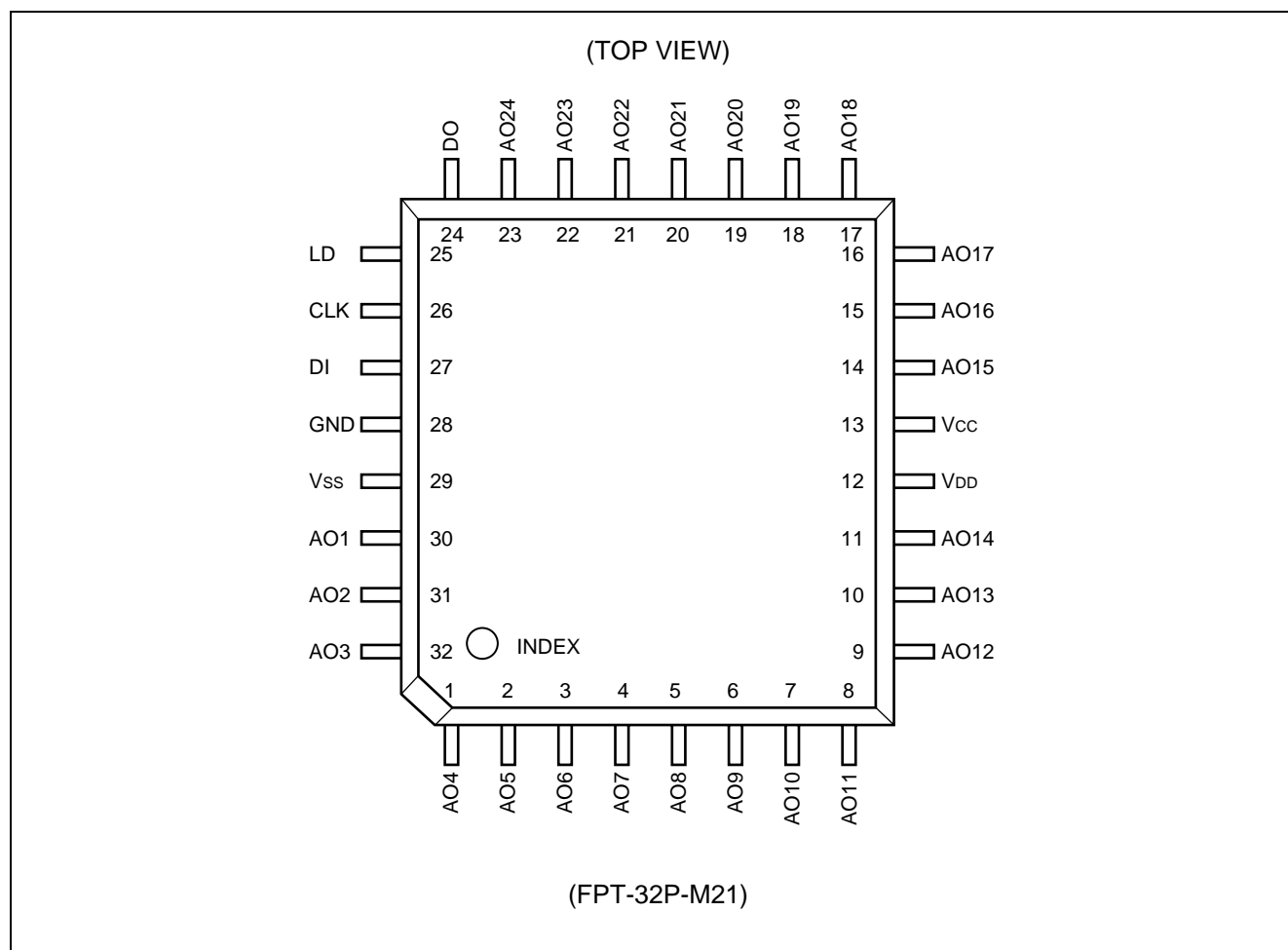

■ PIN DESCRIPTION

Pin No.	Pin name	I/O	Description
27	DI*	I	Serial data input pin. This pin inputs serial data with a data length of 14 bits.
24	DO	O	This pin outputs the MSB data in the 14-bit shift register.
26	CLK*	I	Shift clock input pin. The input signal from the DI pin enters the 14-bit shift register at the rising edge of the shift clock pulse.
25	LD*	I	When the LD pin inputs the High-level signal, shift register value is loaded to the decoder and the D/A output register.
30 to 32 1 to 11 14 to 23	AO1 to AO3 AO4 to AO14 AO15 to AO24	O	8-bit D/A output with OP-amp.
13	V _{CC}	—	MCU interface and OP-amp power-supply pin
28	GND	—	MCU interface and OP-amp GND pin
12	V _{DD}	—	D/A converter power-supply pin
29	V _{SS}	—	D/A converter GND pin

* : DI, CLK, LD pins should be fixed with “Low” level while no data are transferred.

■ BLOCK DIAGRAM

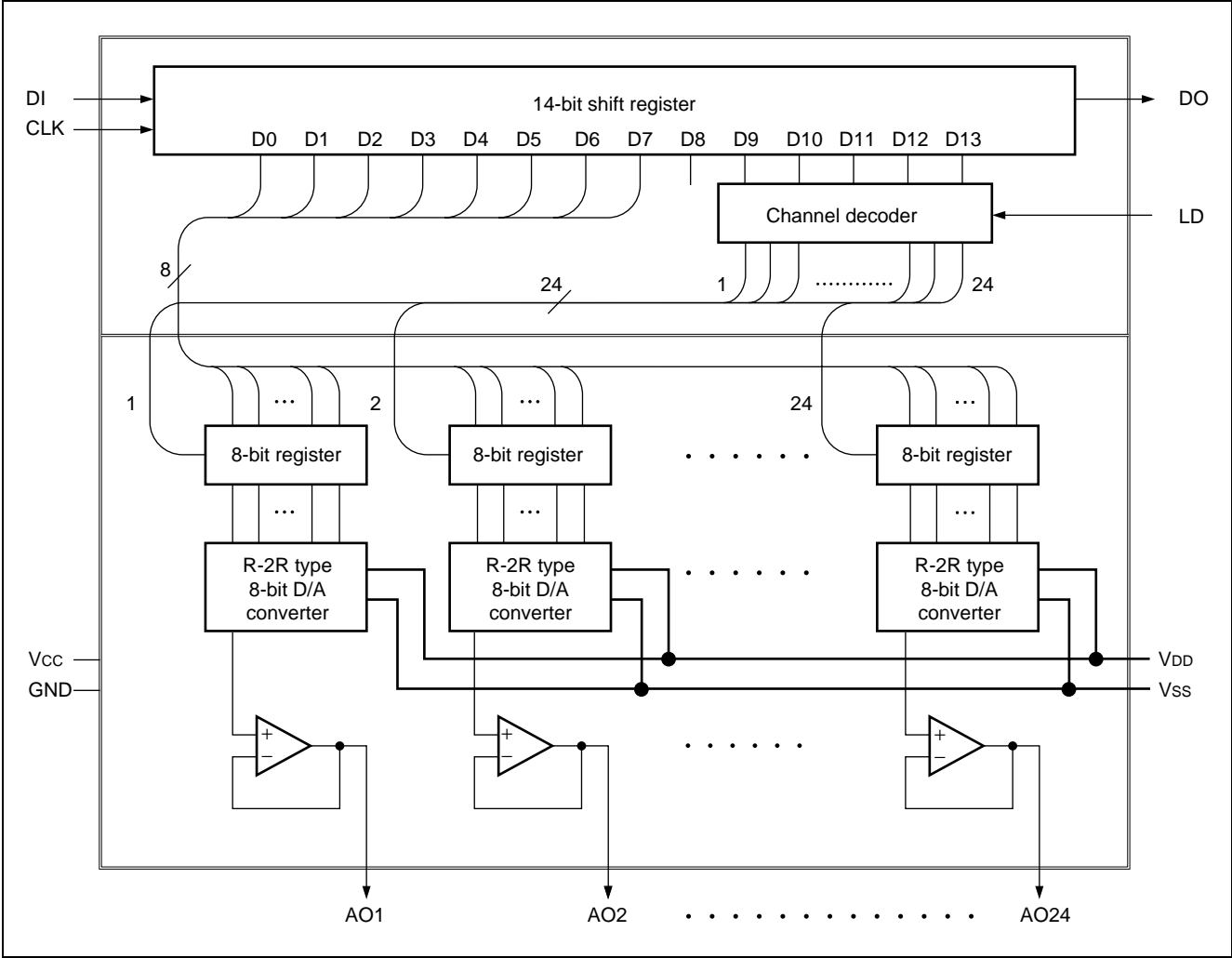

MB88345

■ DATA CONFIGURATION

The MB88345 has a 14-bit shift register for chip control.

The 14-bit shift register must be used to set up data in the configuration shown below.

Note : The data configuration has a total of 14 bits, six for channel selection and eight for D/A data output.

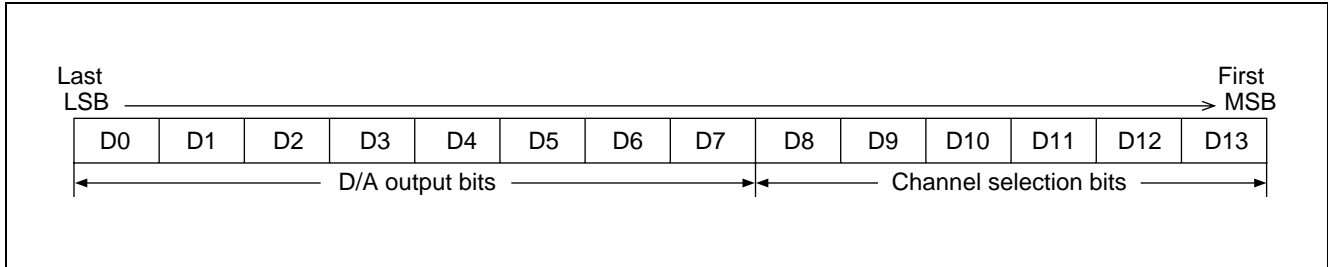

• D/A converter control signals

Input data signal								D/A converter output voltage
D0	D1	D2	D3	D4	D5	D6	D7	
0	0	0	0	0	0	0	0	$\div V_{SS}$
1	0	0	0	0	0	0	0	$\div V_{REF} / 255 \times 1 + V_{SS}$
?	?	?	?	?	?	?	?	?
0	1	1	1	1	1	1	1	$\div V_{REF} / 255 \times 254 + V_{SS}$
1	1	1	1	1	1	1	1	$\div V_{DD}$

$$V_{REF} = V_{DD} - V_{SS}$$

• Channel selection signals

Input data signal						Channel selection
D8	D9	D10	D11	D12	D13	
x	0	0	0	0	0	Deselected
x	0	0	0	0	1	AO1 Selection
x	0	0	0	1	0	AO2 Selection
?	?	?	?	?	?	?
x	1	0	1	1	1	AO23 Selection
x	1	1	0	0	0	AO24 Selection
x	1	1	0	0	1	Deselected
x	1	1	0	1	0	
?	?	?	?	?	?	
x	1	1	1	1	0	
x	1	1	1	1	1	

x : Don't Care

■ TIMING CHART

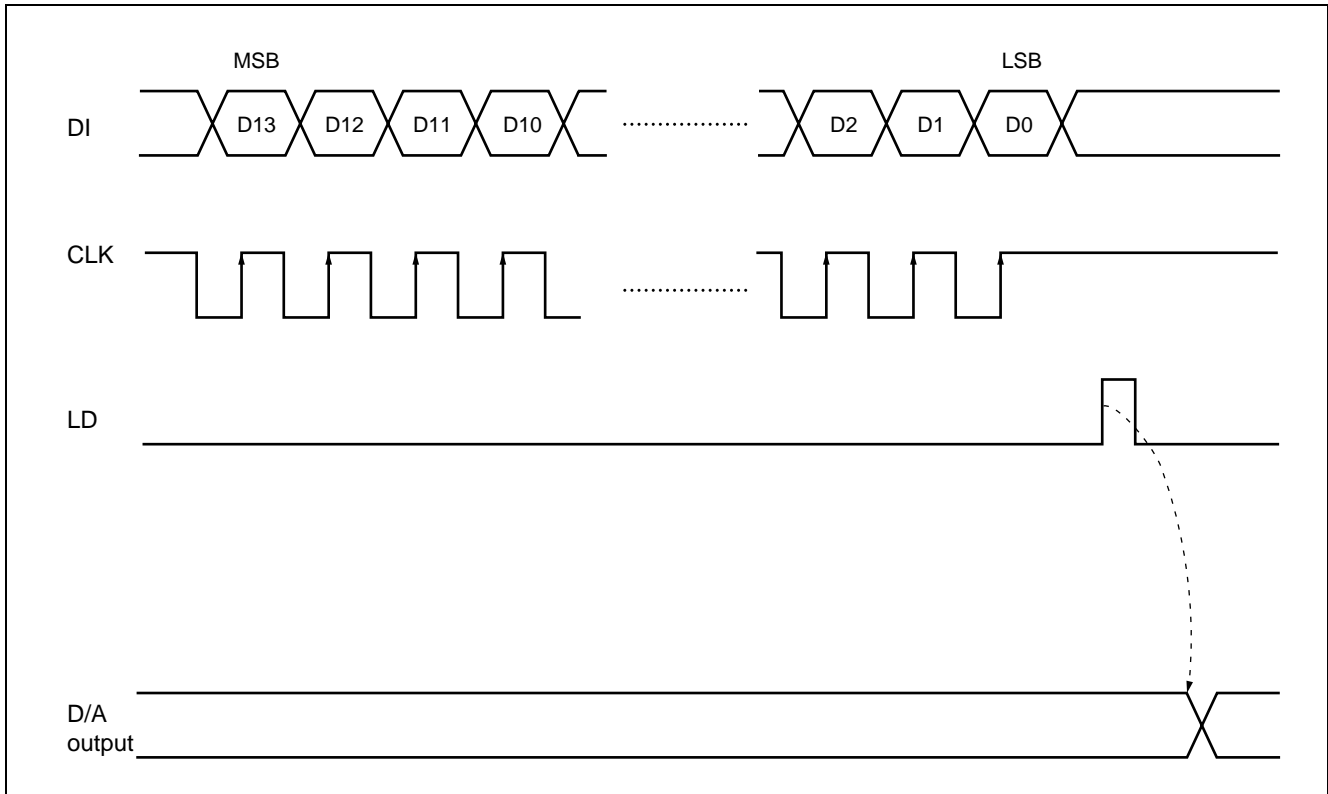

■ ANALOG OUTPUT VOLTAGE RANGE

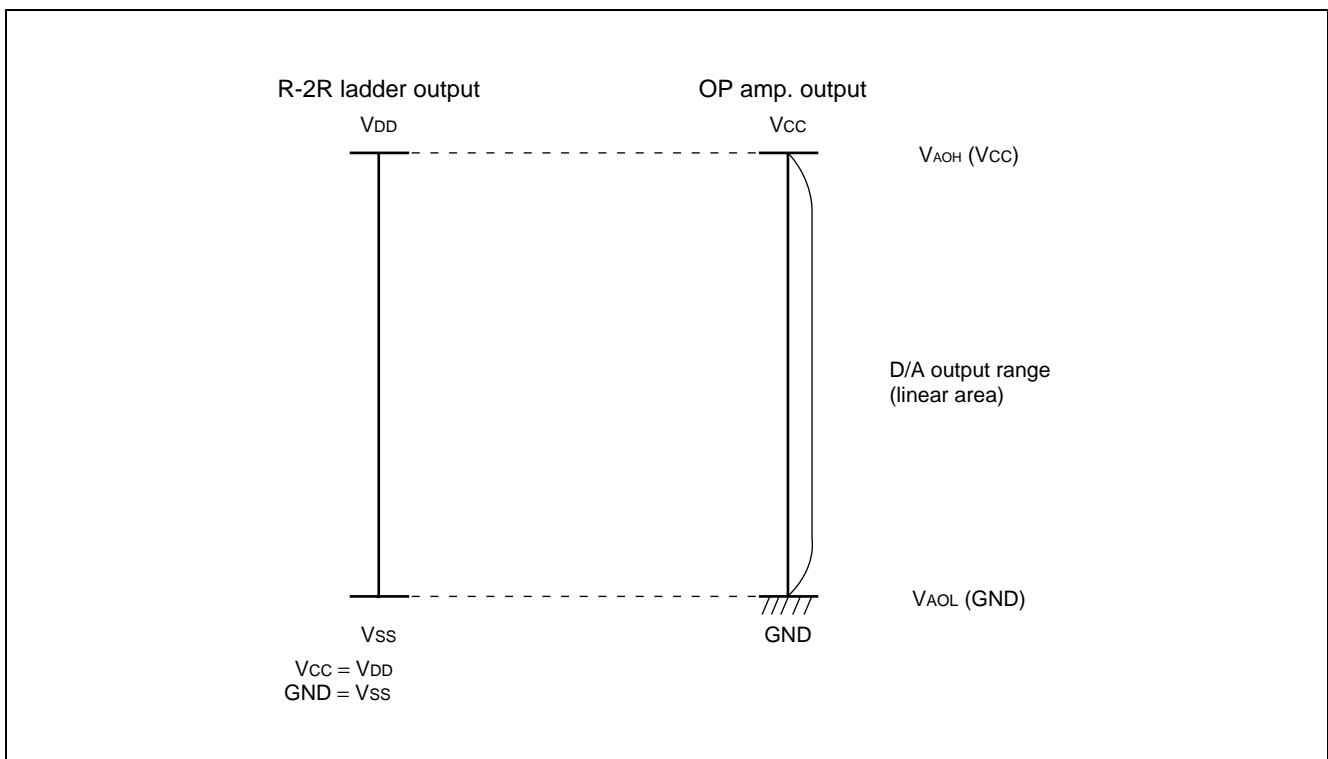

MB88345

■ ABSOLUTE MAXIMUM RATINGS

Parameter	Symbol	Conditions	Rating		Unit
			Min.	Max.	
Power supply voltage	V _{CC}	Based on GND T _a = +25 °C	-0.3	+7.0	V
	V _{DD}		-0.3*	+7.0*	V
Input voltage	V _{IN}		-0.3	V _{CC} + 0.3	V
Output voltage	V _{OUT}		-0.3	V _{CC} + 0.3	V
Power consumption	P _D	—	—	250	mW
Operating temperature	T _a	—	-20	+85	°C
Storage temperature	T _{stg}	—	-55	+150	°C

* : V_{CC} ≥ V_{DD}

WARNING: Semiconductor devices can be permanently damaged by application of stress (voltage, current, temperature, etc.) in excess of absolute maximum ratings. Do not exceed these ratings.

■ RECOMMENDED OPERATING CONDITIONS

Parameter	Symbol	Conditions	Value	Unit
Power supply voltage 1	V _{CC}	—	5 V ± 10 %	V
	GND		0	V
Power supply voltage 2	V _{DD}	V _{DD} - V _{SS} ≥ 2.0 V	2.0 to V _{CC}	V
	V _{SS}		GND to V _{CC} - 2.0	V
Analog output source current	I _{AL}	—	max. 1.0	mA
Analog output sink current	I _{AH}		max. 1.0	mA
Oscillation limit output capacity	C _{OL}		max. 1.0	μF
Digital data value range	—		#00 to #FF	—
Operating temperature	T _a		-20 to +85	°C

WARNING: The recommended operating conditions are required in order to ensure the normal operation of the semiconductor device. All of the device's electrical characteristics are warranted when the device is operated within these ranges.

Always use semiconductor devices within their recommended operating condition ranges. Operation outside these ranges may adversely affect reliability and could result in device failure.

No warranty is made with respect to uses, operating conditions, or combinations not represented on the data sheet. Users considering application outside the listed conditions are advised to contact their FUJITSU representatives beforehand.

■ ELECTRICAL CHARACTERISTICS

1. DC Characteristics

(1) Digital block

(V_{DD} , $V_{CC} = +5\text{ V} \pm 10\%$ ($V_{CC} \geq V_{DD}$), GND, $V_{SS} = 0\text{ V}$, $T_a = -20\text{ }^\circ\text{C}$ to $+85\text{ }^\circ\text{C}$)

Parameter	Symbol	Pin name	Conditions	Value			Unit
				Min.	Typ.	Max.	
Power supply voltage	V_{CC}	V_{CC}	—	4.5	5.0	5.5	V
Power supply current	I_{CC}		Operation at CLK = 1 MHz (No load)	—	2.4	5.4	mA
Input leak current	I_{ILK}	CLK DI LD	$V_{IN} = 0$ to V_{CC}	-10	—	10	μA
“L” level input voltage	V_{IL}		—	—	—	$0.2 V_{CC}$	V
“H” level input voltage	V_{IH}		—	$0.5 V_{CC}$	—	—	V
“L” level output voltage	V_{OL}	DO	$I_{OL} = 2.5\text{ mA}$	—	—	0.4	V
“H” level output voltage	V_{OH}		$I_{OH} = -400\text{ }\mu\text{A}$	$V_{CC} - 0.4$	—	—	V

(2) Analog block (1)

(V_{DD} , $V_{CC} = +5\text{ V} \pm 10\%$ ($V_{CC} \geq V_{DD}$), GND, $V_{SS} = 0\text{ V}$, $T_a = -20\text{ }^\circ\text{C}$ to $+85\text{ }^\circ\text{C}$)

Parameter	Symbol	Pin name	Conditions	Value			Unit
				Min.	Typ.	Max.	
Power consumption	I_{DD}	V_{DD}	No load	—	3.0	4.5	mA
Analog Voltage	V_{DD}		V_{SS}	$V_{DD} - V_{SS} \geq 2.0\text{ V}$	2.0	—	V_{CC}
	V_{SS}	GND			—	$V_{CC} - 2.0$	V
Resolution	Res	AO1 to AO24	—	—	8	—	bit
Monotonic increase	Rem		No load	—	8	—	bit
Non-linearity error	LE		$V_{DD} \leq V_{CC} - 0.1\text{ V}$ $V_{SS} \geq 0.1\text{ V}$	-1.5	—	1.5	LSB
Differential linearity error	DLE			-1.0	—	1.0	LSB

Nonlinearity error : Deviation (error) in input/output curves with respect to an ideal straight line connecting output voltage at “00” and output voltage at “FF.”

Differential linearity error : Deviation (error) in amplification with respect to theoretical increase in amplification per 1-bit increase in digital value.

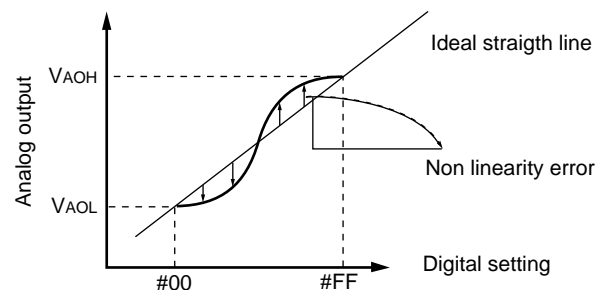

Note : The value of V_{AOH} and V_{DD} , and the value of V_{AOL} and V_{SS} are not necessarily equivalent.

MB88345

(3) Analog block (2)

(V_{DD} , $V_{CC} = +5\text{ V} \pm 10\%$ ($V_{CC} \geq V_{DD}$), GND , $V_{SS} = 0\text{ V}$, $T_a = -20\text{ }^\circ\text{C}$ to $+85\text{ }^\circ\text{C}$)

Parameter	Symbol	Pin name	Conditions	Value			Unit
				Min.	Typ.	Max.	
Output minimum voltage 1	V_{AOL1}	AO1 to AO24	$V_{DD} = V_{CC}$ $V_{SS} = GND = 0\text{ V}$ $I_{AL} = 0\text{ }\mu\text{A}$ Digital data = #00	V_{SS}	—	$V_{SS} + 0.1$	V
Output minimum voltage 2	V_{AOL2}		$V_{DD} = V_{CC} = 5.0\text{ V}$ $V_{SS} = GND = 0\text{ V}$ $I_{AL} = 500\text{ }\mu\text{A}$ Digital data = #00	$V_{SS} - 0.2$	V_{SS}	$V_{SS} + 0.2$	V
Output minimum voltage 3	V_{AOL3}		$V_{DD} = V_{CC} = 5.0\text{ V}$ $V_{SS} = GND = 0\text{ V}$ $I_{AH} = 500\text{ }\mu\text{A}$ Digital data = #00	V_{SS}	—	$V_{SS} + 0.2$	V
Output minimum voltage 4	V_{AOL4}		$V_{DD} = V_{CC} = 5.0\text{ V}$ $V_{SS} = GND = 0\text{ V}$ $I_{AL} = 1.0\text{ mA}$ Digital data = #00	$V_{SS} - 0.3$	V_{SS}	$V_{SS} + 0.3$	V
Output minimum voltage 5	V_{AOL5}		$V_{DD} = V_{CC} = 5.0\text{ V}$ $V_{SS} = GND = 0\text{ V}$ $I_{AH} = 1.0\text{ mA}$ Digital data = #00	V_{SS}	—	$V_{SS} + 0.3$	V
Output maximum voltage 1	V_{AOH1}		$V_{DD} = V_{CC}$ $V_{SS} = GND = 0\text{ V}$ $I_{AL} = 0\text{ }\mu\text{A}$ Digital data = #FF	$V_{DD} - 0.1$	—	V_{DD}	V
Output maximum voltage 2	V_{AOH2}		$V_{DD} = V_{CC} = 5.0\text{ V}$ $V_{SS} = GND = 0\text{ V}$ $I_{AL} = 500\text{ }\mu\text{A}$ Digital data = #FF	$V_{DD} - 0.2$	—	V_{DD}	V
Output maximum voltage 3	V_{AOH3}		$V_{DD} = V_{CC} = 5.0\text{ V}$ $V_{SS} = GND = 0\text{ V}$ $I_{AH} = 500\text{ }\mu\text{A}$ Digital data = #FF	$V_{DD} - 0.2$	V_{DD}	$V_{DD} + 0.2$	V
Output maximum voltage 4	V_{AOH4}		$V_{DD} = V_{CC} = 5.0\text{ V}$ $V_{SS} = GND = 0\text{ V}$ $I_{AL} = 1.0\text{ mA}$ Digital data = #FF	$V_{DD} - 0.3$	—	V_{DD}	V
Output maximum voltage 5	V_{AOH5}		$V_{DD} = V_{CC} = 5.0\text{ V}$ $V_{SS} = GND = 0\text{ V}$ $I_{AH} = 1.0\text{ mA}$ Digital data = #FF	$V_{DD} - 0.3$	V_{DD}	$V_{DD} + 0.3$	V

2. AC Characteristics

(V_{DD} , $V_{CC} = +5\text{ V} \pm 10\%$ ($V_{CC} \geq V_{DD}$), GND, $V_{SS} = 0\text{ V}$, $T_a = -20\text{ }^\circ\text{C}$ to $+85\text{ }^\circ\text{C}$)

Parameter	Symbol	Conditions	Value		Unit
			Min.	Max.	
"L" level clock pulse width	tCKL	—	200	—	ns
"H" level clock pulse width	tCKH		200	—	ns
Clock rise time	tCr		—	200	ns
Clock fall time	tCf				
Data setup time	tDCH		30	—	ns
Data hold time	tCHD		60	—	ns
Load setup time	tCHL		200	—	ns
Load hold time	tLDC		100	—	ns
"H" level load pulse width	tLDH	100	—	ns	
Data output delay time	tDO	See "Load conditions (1)"	—	150	ns
D/A output setting time	tLDD	See "Load conditions (2)"	—	100	μs

- Load conditions

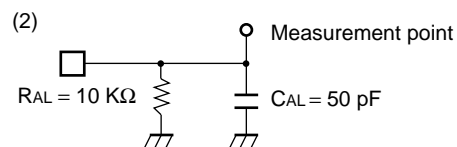
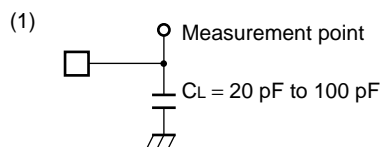

MB88345

- Input/output timing

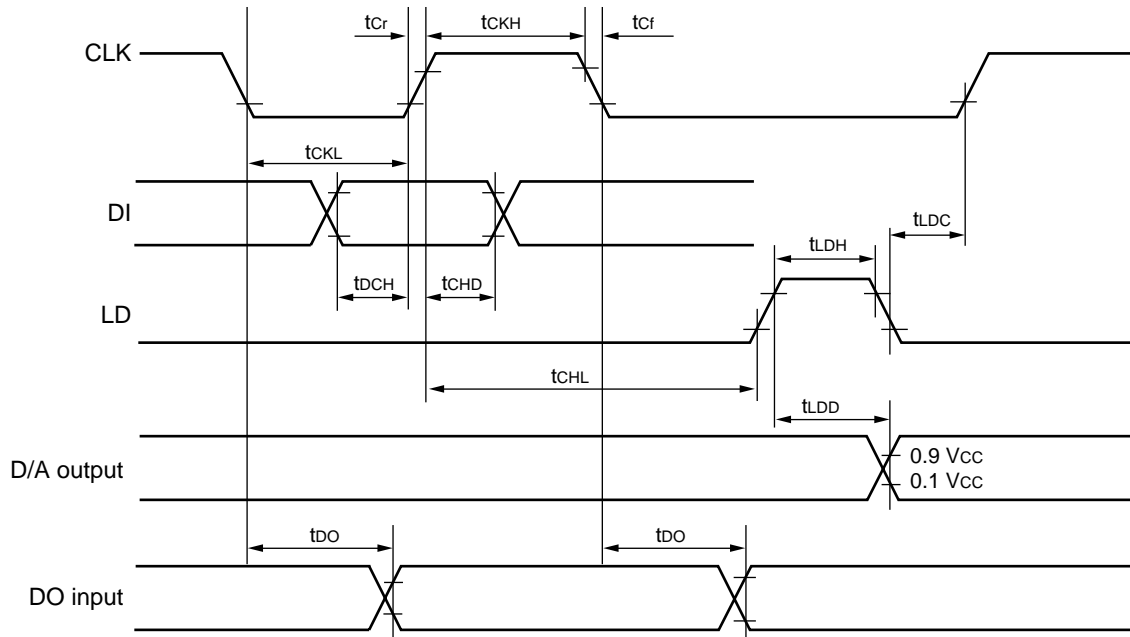

Note : Digital input decision level : 50% and 20% of V_{CC} .
Digital output decision level : 80% and 20% of V_{CC} .
Analog output decision level : 90% and 10% of V_{CC} .

■ VAO vs. IAO CHARACTERISTICS EXAMPLE

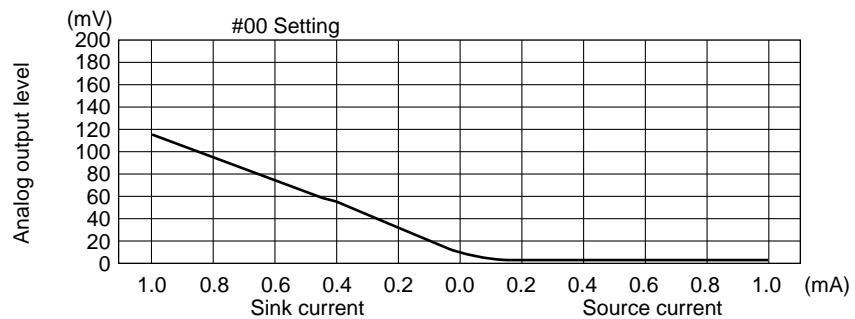
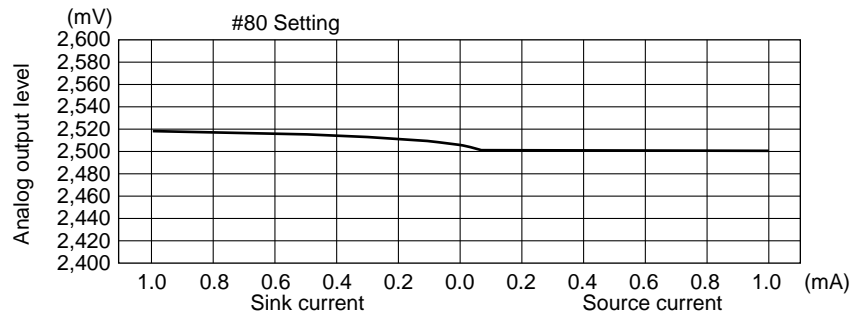
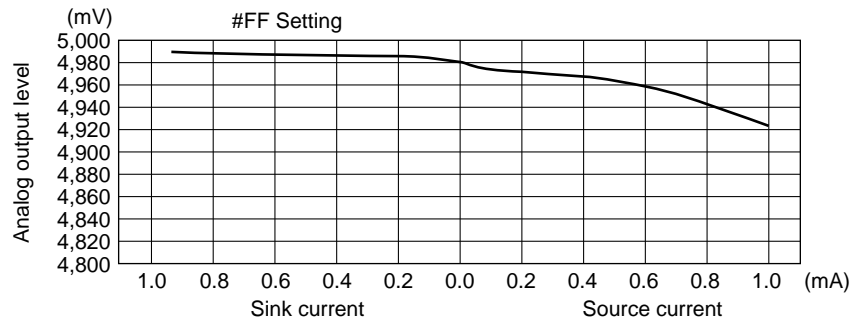
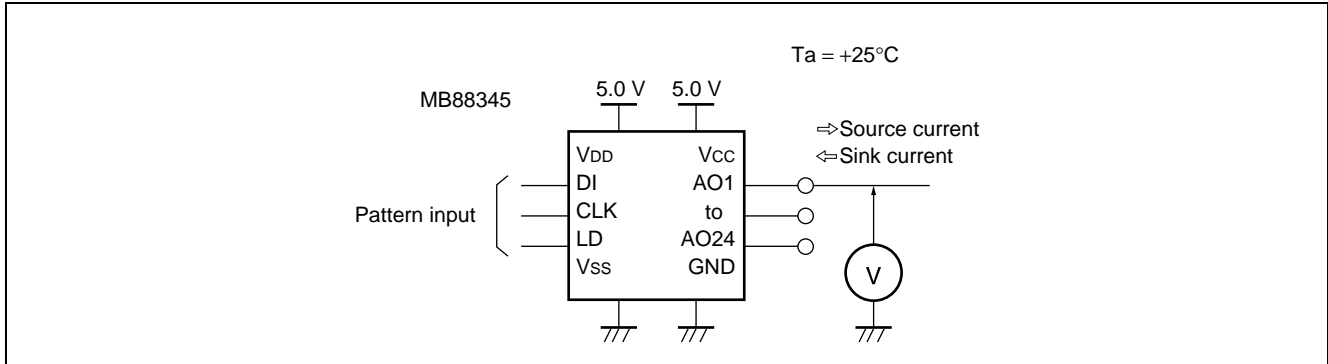

MB88345

■ ORDERING INFORMATION

Part number	Package	Remarks
MB88345PF	32 pin Plastic QFP (FPT-32P-M21)	

■ PACKAGE DIMENSION

32-pin, Plastic QFP
(FPT-32P-M21)

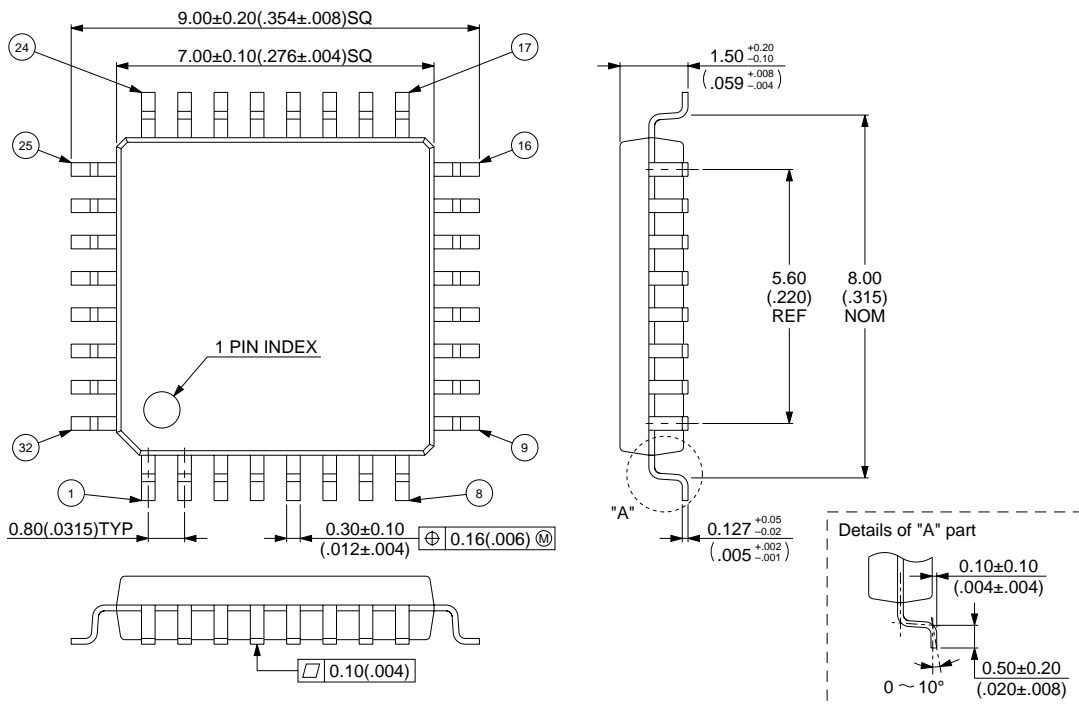

© 1994 FUJITSU LIMITED F32032S-1C-2

Dimensions in mm (inches)

FUJITSU LIMITED

For further information please contact:

Japan

FUJITSU LIMITED
Corporate Global Business Support Division
Electronic Devices
KAWASAKI PLANT, 4-1-1, Kamikodanaka,
Nakahara-ku, Kawasaki-shi,
Kanagawa 211-8588, Japan
Tel: +81-44-754-3763
Fax: +81-44-754-3329

<http://www.fujitsu.co.jp/>

North and South America

FUJITSU MICROELECTRONICS, INC.
3545 North First Street,
San Jose, CA 95134-1804, USA
Tel: +1-408-922-9000
Fax: +1-408-922-9179

Customer Response Center
Mon. - Fri.: 7 am - 5 pm (PST)
Tel: +1-800-866-8608
Fax: +1-408-922-9179

<http://www.fujitsumicro.com/>

Europe

FUJITSU MICROELECTRONICS EUROPE GmbH
Am Siebenstein 6-10,
D-63303 Dreieich-Buchsschlag,
Germany
Tel: +49-6103-690-0
Fax: +49-6103-690-122

<http://www.fujitsu-fme.com/>

Asia Pacific

FUJITSU MICROELECTRONICS ASIA PTE LTD
#05-08, 151 Lorong Chuan,
New Tech Park,
Singapore 556741
Tel: +65-281-0770
Fax: +65-281-0220

<http://www.fmap.com.sg/>

All Rights Reserved.

The contents of this document are subject to change without notice.

Customers are advised to consult with FUJITSU sales representatives before ordering.

The information and circuit diagrams in this document are presented as examples of semiconductor device applications, and are not intended to be incorporated in devices for actual use. Also, FUJITSU is unable to assume responsibility for infringement of any patent rights or other rights of third parties arising from the use of this information or circuit diagrams.

The contents of this document may not be reproduced or copied without the permission of FUJITSU LIMITED.

FUJITSU semiconductor devices are intended for use in standard applications (computers, office automation and other office equipments, industrial, communications, and measurement equipments, personal or household devices, etc.).
CAUTION:

Customers considering the use of our products in special applications where failure or abnormal operation may directly affect human lives or cause physical injury or property damage, or where extremely high levels of reliability are demanded (such as aerospace systems, atomic energy controls, sea floor repeaters, vehicle operating controls, medical devices for life support, etc.) are requested to consult with FUJITSU sales representatives before such use. The company will not be responsible for damages arising from such use without prior approval.

Any semiconductor devices have inherently a certain rate of failure. You must protect against injury, damage or loss from such failures by incorporating safety design measures into your facility and equipment such as redundancy, fire protection, and prevention of over-current levels and other abnormal operating conditions.

If any products described in this document represent goods or technologies subject to certain restrictions on export under the Foreign Exchange and Foreign Trade Control Law of Japan, the prior authorization by Japanese government should be required for export of those products from Japan.