

# NEC

## NPN SILICON TRANSISTOR BA1F4N

**DESCRIPTION** The BA1F4N is designed for use in medium speed switching circuit.

**FEATURE** • Bias resistors built-in type NPN transistor equivalent circuit.

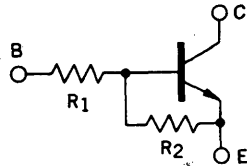

$R_1 = 22 \text{ k}\Omega$

$R_2 = 47 \text{ k}\Omega$

### ABSOLUTE MAXIMUM RATINGS

**Maximum Temperatures**

Storage Temperature . . . . .  $-55$  to  $+150$  °C

Junction Temperature . . . . .  $150$  °C Maximum

**Maximum Power Dissipation ( $T_a = 25$  °C)**

Total Power Dissipation . . . . .  $250$  mW

**Maximum Voltages and Currents ( $T_a = 25$  °C)**

$V_{CBO}$  Collector to Base Voltage . . . . .  $60$  V

$V_{CEO}$  Collector to Emitter Voltage . . . . .  $50$  V

$V_{EBO}$  Emitter to Base Voltage . . . . .  $5.0$  V

$I_{C(DC)}$  Collector Current (DC) . . . . .  $100$  mA

$I_{C(pulse)}$  Collector Current (pulse) . . . . .  $200$  mA

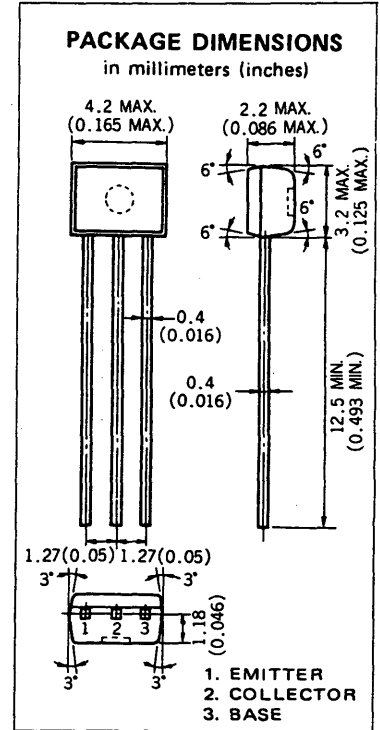

### ELECTRICAL CHARACTERISTICS ( $T_a = 25$ °C)

SYMBOL	CHARACTERISTIC	MIN.	TYP.	MAX.	UNIT	TEST CONDITIONS
$R_1$	Input Resistance	15.4	22.0	28.6	$\text{k}\Omega$	
$R_2$	Input Resistance	32.9	47.0	61.1	$\text{k}\Omega$	
$V_{IL}$	Low Level Input Voltage		0.8	0.6	V	$V_{CE} = 5.0 \text{ V}, I_C = 100 \mu\text{A}$
$V_{IH}$	Hi Level Input Voltage	3.0	1.3		V	$V_{CE} = 0.2 \text{ V}, I_C = 5.0 \text{ mA}$
$t_{on}$	Turn On Time		0.2	0.3	$\mu\text{s}$	$V_{CC} = 5.0 \text{ V}, R_L = 1.0 \text{ k}\Omega,$ $V_{in} = 5.0 \text{ V},$ $PW = 2 \mu\text{s}, \text{Duty Cycle} \leq 2\%$
$t_{stg}$	Storage Time		3.0	5.0	$\mu\text{s}$	
$t_{off}$	Turn Off Time		3.5	6.0	$\mu\text{s}$	
$h_{FE1}$	DC Current Gain	85	200	340	—	$V_{CE} = 5.0 \text{ V}, I_C = 5.0 \text{ mA}$
$h_{FE2}$	DC Current Gain	95	230		—	$V_{CE} = 5.0 \text{ V}, I_C = 50 \text{ mA}$
$V_{CE(sat)}$	Collector Saturation Voltage		0.04	0.2	V	$I_C = 5.0 \text{ mA}, I_B = 0.25 \text{ mA}$
$I_{CBO}$	Collector Cutoff Current			0.1	$\mu\text{A}$	$V_{CB} = 50 \text{ V}, I_E = 0$

TYPICAL CHARACTERISTICS ( $T_a = 25^\circ\text{C}$ )

