

# Mute detector IC

## BA336 / BA338 / BA338L

The BA336, BA338 and BA338L are monolithic ICs designed for mute detection and tape end detection. When a duration of silence (52dBm or less) exceeds the time constant set with an external CR circuit, a song gap is identified, and after this a plunger control signal is output during a pulse whose width is determined by another external CR circuit. These functions are contained in a compact 9-pin package.

The circuit configuration consists of a pre-amp with limiter, a comparator flip-flop, and a driver. Circuitry is also included which prevents errors when the power is turned on, and measures have been taken to prevent errors due to excessive input, song gap noise, and other factors.

### ●Applications

Mute detection

Tape end detection

### ●Features

- 1) Mute detection time and output pulse width can be set within a broad range by an external CR circuit.
- 2) Includes circuit for preventing errors due to song gap noise.
- 3) Includes over-current protection circuit.
- 4) Includes circuit for preventing errors when the power is turned on.
- 5) Detection can be stopped using an external input.

### ●Absolute maximum ratings (Ta = 25°C)

Parameter		Symbol	Limits	Unit
Power supply voltage		V <sub>CC</sub>	16	V
Power dissipation	BA336/BA338	P <sub>d</sub>	540*1	mW
	BA338L		500*1	
Operating temperature		T <sub>opr</sub>	-20~+75	°C
Storage temperature		T <sub>stg</sub>	-50~+125	°C
Over-current protection time		T <sub>STOL</sub>	0.1*2	s

\*1 Reduced by 5.4mW (BA336/BA338) and 5mW (BA338L) for each increase in Ta of 1°C over 25°C.

\*2 V<sub>CC</sub>=16V, R<sub>L</sub>=20Ω

### ●Recommended operating conditions (Ta = 25°C)

Parameter	Symbol	Min.	Typ.	Max.	Unit
Power supply voltage	V <sub>CC</sub>	4.2	—	12	V

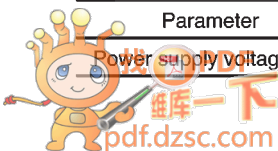

● Block diagram

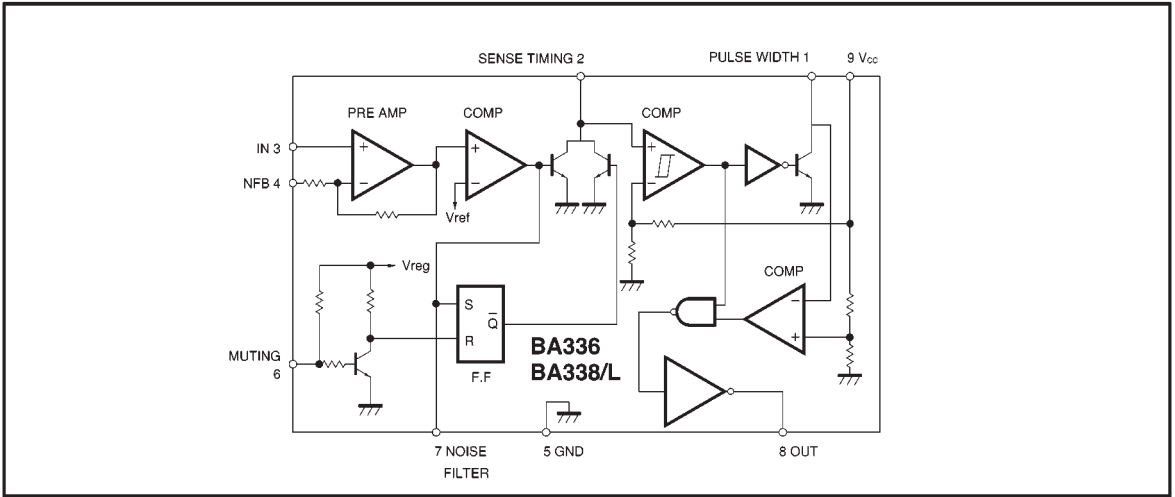

● Electrical characteristics (unless otherwise noted, Ta = 25°C and Vcc = 9.0V)

Parameter	Symbol	Min.	Typ.	Max.	Unit	Conditions	
Quiescent current	I <sub>Q</sub>	—	6.5	11	mA	—	
Input discrimination level	V <sub>IN</sub>	-55	-52	-49	dBm	f=10kHz, C <sub>f</sub> =1 μF	
Input current	I <sub>IN</sub>	—	0.2	2.0	μA	—	
Mute detection time accuracy	BA336 BA338/L	T <sub>ERR (D)</sub>	—	3	10	%	R <sub>D</sub> =500kΩ, C <sub>D</sub> =0.1 μF
					—		R <sub>D</sub> =510kΩ, C <sub>D</sub> =0.056 μF
Output pulse width accuracy	BA336 BA338/L	T <sub>ERR (W)</sub>	—	3	10	%	R <sub>D</sub> =500kΩ, C <sub>D</sub> =0.01 μF
					—		R <sub>D</sub> =510kΩ, C <sub>D</sub> =0.056 μF
Output low level voltage	V <sub>OL</sub>	—	0.3	0.5	V	I <sub>SINK</sub> =3.5mA	
Output high level voltage	V <sub>OH</sub>	6.0	7.0	—	V	I <sub>PRURCE</sub> =80mA	
Output limit current	BA336 BA338/L	I <sub>LIM</sub>	80	150	—	mA	—
			—				
Pin 6 threshold voltage	V <sub>6TH</sub>	0.7	1.2	1.8	V	*	
Pin 6 output current	BA336 BA338/L	I <sub>SD</sub>	30	70	115	μA	V <sub>P6</sub> (6pin Voltage)=0V
			—		—		
Pin 7 threshold voltage	BA336 BA338/L	V <sub>7TH</sub>	0.5	0.65	0.8	V	Measure with pin 2 at 4.5V
Pin 7 output current	BA338/L	I <sub>NO</sub>	—	200	—	μA	V <sub>P7</sub> (7pin Voltage)=0V, 3pin Voltage=1V

\* When the mute pin (Pin 6) is below 0.7 V, the detection function is disabled and an output pulse is not generated.  
When above 1.8 V the detection function is on standby.

● Measurement circuit

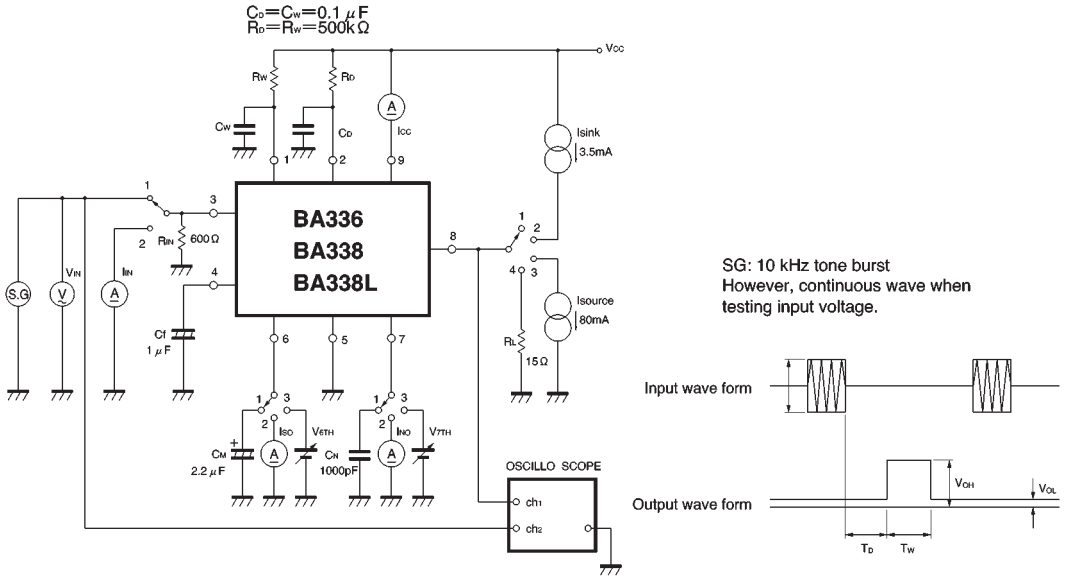

Fig. 1

● Circuit operation

The BA336 / BA338 / BA338L operates according to the timing shown in Fig. 2. When the input signal is below the input decision level, the electrical potential of Pin 2 begins to rise according to the time constant set by  $C_D$  and  $R_D$ . When it reaches  $1 / 2$  of  $V_{CC}$ , the comparator which sets the mute detection time inverts. At this point the potential of Pin 1 begins to rise according to the time constant set by  $C_W$  and  $R_W$ , and when it reaches  $1 / 2$  of  $V_{CC}$ , the pulse width comparator inverts. During the interval from the inverting of the mute detection time

comparator, the output is high. When the power is turned on or muting is turned off, a reset pulse is generated for a certain period of time (determined by the Pin 6 capacitor), the internal flip-flop resets, and an output pulse is not generated. When an input signal comes in after this, the flip-flop resets, mute detection goes on standby, and an output pulse is obtained with each song gap. If the mute time is  $T_M$ , the song detection time  $T_D$  and the output pulse width  $T_W$  must be selected so that  $T_D + T_W < T_M$ . Furthermore,  $T_D$  must be made longer than any periods of silence in songs.

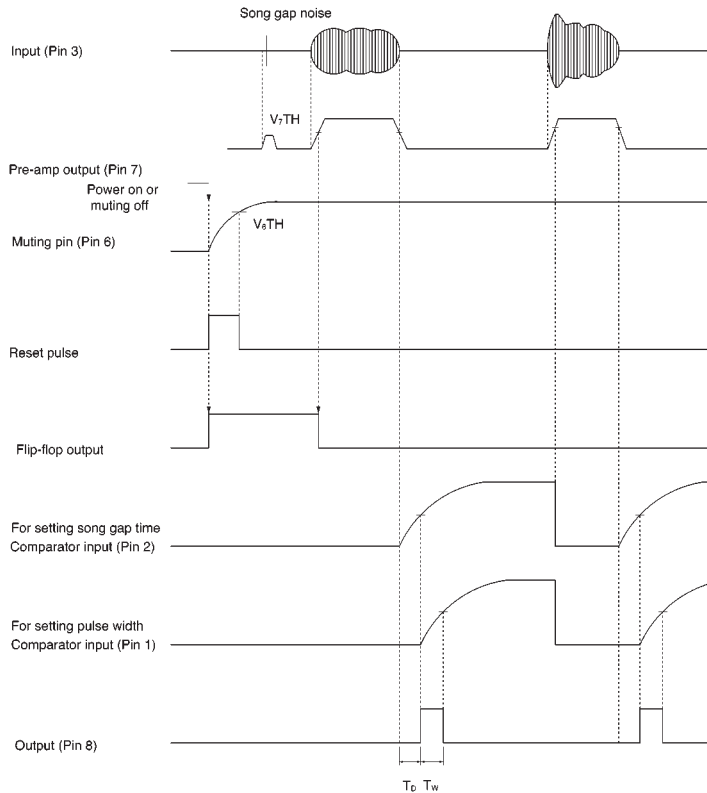

Fig. 2 Timing chart

●Application example

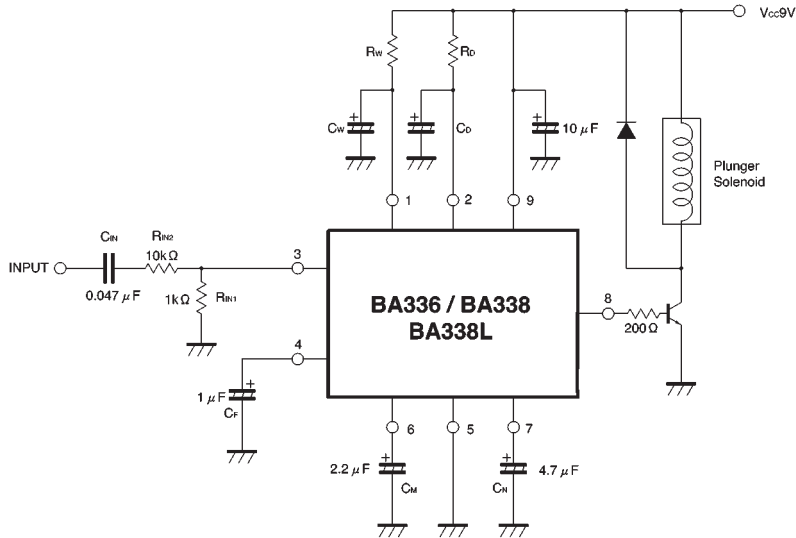

Fig. 3

●Attached components (see Fig. 3)

(1) Input coupling capacitor  $C_{IN}$  and resistor  $R_{IN}$  (Pin 3)  
This capacitor is for coupling a pre-amp to the BA336 / BA338 / BA338L.

If the DC level of the pre-amp output is GND, the coupling capacitor can be omitted. If a coupling capacitor is connected, Pin 3 must be connected to GND through a resistor. If the resistor between Pin 3 and GND is too large, an offset will occur due to a voltage drop caused by the input current, and the input decision level will change. We recommend  $10k\Omega$  or less. The input decision level of the BA336 / BA338 / BA338L is highly sensitive at  $-52dBm$ . In the application example, the pre-stage output is divided to adjust the sensitivity and increase the input impedance. Furthermore, the low cutoff frequency  $f_c$  is determined by the input circuit time constant or the Pin 4 time constant, whichever is smaller. As it is better to determine  $f_c$  by the Pin 4  $C_F$  when the power is turned on, we recommend making the time constant of the input circuit larger than that of Pin 4.

(2) DC cutoff capacitor in feedback circuit  $C_F$  (Pin 4)  
This determines the low cutoff frequency  $f_c$ . The relation of  $C_F$  and  $f_c$  is as follows :

$$C_F = \frac{1}{0.4\pi f_c} \text{ (}\mu\text{F)}$$

If  $C_F = 1\mu\text{F}$ ,  $f_c \approx 800\text{Hz}$ .

The larger  $C_F$  is, the more time it will take for the circuit

to stabilize when the power is turned on.

(3) Muting capacitor for power up  $C_M$  (Pin 6)  
After the power is turned on, this capacitor stops song selection until the circuit stabilizes. If the value of  $C_F$  is large, a large  $C_M$  will also be necessary.  $C_M$  must be greater than  $C_F$ . Also, if it takes longer for the external circuit to stabilize, select  $C_M$  based on the external circuit. The relation between  $C_M$  and the muting time is as follows :

$$T_M \approx 30C_M \text{ (}\mu\text{F)}$$

(4) Noise filter capacitor  $C_N$  (Pin 7)  
This capacitor prevents errors due to pulse noise. When an input signal is shorter than the time determined by  $T_N = C_N \text{ (}\mu\text{F)}$  ms (BA338 / BA338L) or  $T_N = 20C_N \text{ (}\mu\text{F)}$  ms (BA336), the IC will not respond and an output pulse will not be generated. If pulse noise appears continuously at the input, the effectiveness of the noise filter will be decreased. If it is likely that continuous noise will appear, attach a discharge resistor  $R_N$  between Pin 7 and GND ( $R_N \geq 30k\Omega$ ).

There are differences in the noise filter functions of the BA336 and the BA338 / BA338L. Refer to the section, "Differences between the noise filters of the BA336 and BA338 / BA338L".

(5) Capacitor  $C_W$  and resistor  $R_W$  (Pin 1) for setting output pulse width

The relation between  $C_W$ ,  $R_W$  and the output pulse width  $T_W$  is as follows :

$$T_W \approx 0.69 \times C_W (\mu F) \times R_W (k\Omega) \text{ ms}$$

$T_W$  is almost independent of the supply voltage.

If  $R_W$  is small (less than 10k $\Omega$ ), errors increase.

See Fig. 8.

(6) Capacitor  $C_D$  and resistor  $R_D$  (Pin 2) for setting song gap detection time

The relation between  $C_D$ ,  $R_D$  and the detection time  $T_D$  (the duration from the point when the input signal goes below the input decision level to the generation of the output pulse) is as follows :

BA336 :

$$T_D = 0.69 \times C_D (\mu F) \times R_D (k\Omega)$$

BA338 / BA338L :

$$T_D = 0.69 \times C_D (\mu F) \times R_D (k\Omega) + 0.15 \times C_N (\mu F) \times R_N (k\Omega)$$

(The internal resistor  $R_N$  is 25 to 100k $\Omega$ .)

$T_D$  is almost independent of the supply voltage.

If  $R_D$  is small (less than 10k $\Omega$ ), errors increase.

See Fig. 8.

● Operation notes

(1) The input decision level of the BA336 / BA338 / BA338L is a highly sensitive -52dBm. This can cause the output current to return to the input through the common impedance of the ground line. Be sure to decouple the power supply line and prevent common impedance with the ground line. Adding a 0.1 $\mu F$  capacitor between Pin 8 and GND is effective, and we strongly recommend doing so when high current is used.

(2) The maximum output current of the BA336 / BA338 / BA338L can be up to 150mA (typical). However, if left in the current limited state for a long time when using a high voltage power supply, damage to the IC can result. Be sure not to exceed the rated power dissipation and the over-current protection time.

(3) When the BA336 / BA338 / BA338L is input into a counter IC, make sure the input is above the 2V<sub>F</sub> threshold (approximately 1.3V). Otherwise, there is a possibility that a miscount will occur due to the output pulse generated (approximately 0.5V, see Fig. 4) when the power is turned on or off.

If a  $C_N$  is added in the case of the BA338 / BA338L, its discharge time will cause  $T_D$  to be slightly longer than it is when  $C_N = 0$ .

Caution is required if  $T_D$  is made short or a large  $C_N$  is used. (See Fig. 9).

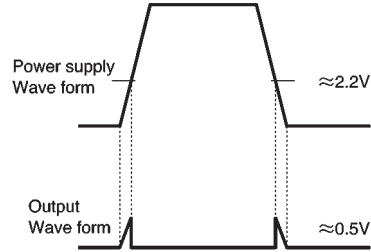
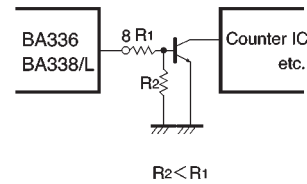

Fig. 4



The threshold is increased by adding  $R_2$ .

Fig. 5 Circuit example

● Differences between the noise filters of the BA336 and BA338 / BA338L

The basic configurations of the BA336 and BA338 / BA338L are the same, however, the noise filters are different.

**BA336** The noise filter only operates from the time the power is turned on or muting is turned off to the arrival of the input signal. The power must be turned off or muting turned on each time an output signal is generated.

**BA338 / BA338L** The noise filter operates continuously while the power is on. However, as noted previously the song gap detection time can change slightly due to the capacitor  $C_N$  connected to the noise filter pin.

●Electrical characteristic curves

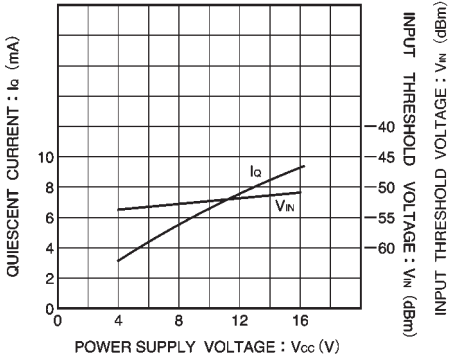

Fig.6 Quiescent current vs. power supply voltage

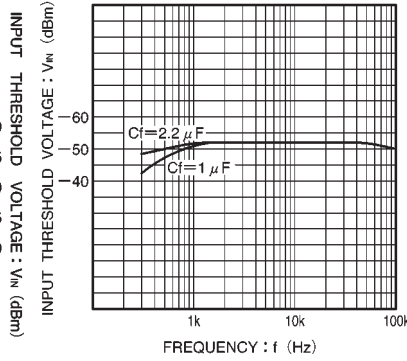

Fig. 7 Input discrimination voltage vs. frequency

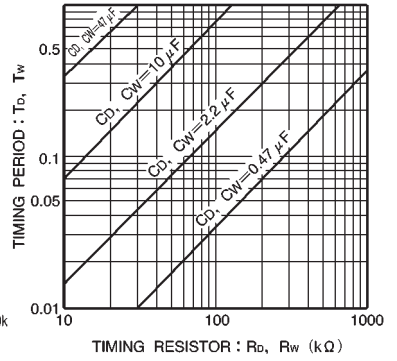

Fig. 8 Relation of external capacitors and resistors to mute detection time  $T_D$  and output pulse width  $T_w$

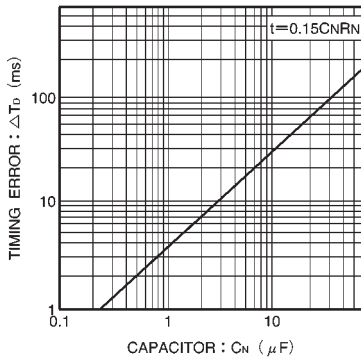

Fig. 9 Relation of  $C_N$  and  $R_N$  to increase of  $T_D$

●External dimensions (Units: mm)

