

Double cassette tape recorder system preamplifier

BA3423S

The BA3423S is a record/playback system preamplifier for radio cassette decks. With four control pins it allows switching between I/O for the A (play only) and B (record and play) mechanisms, input for tape, radio, and microphone, on and off switching for line out and recording output, and equalizer switching for normal and high-speed dubbing. It requires about half the number of external components of its predecessors which means simplified assembly and overall cost savings.

●Applications

Dual-cassette radio cassette players.

●Features

- 1) Built-in switch for playback equalizer amplifier for the A and B mechanisms.
- 2) Built-in normal/high-speed equalizer switch for the playback equalizer amplifier.
- 3) The B mechanism input is also used as the recording output, so a switch is not required.
- 4) Built-in tape/radio input switch, and microphone mixing.
- 5) The microphone amplifier is used as the mixing amplifier, and the line can be muted to allow the built-in microphone to be used for recording.
- 6) Built-in ALC circuit.
- 7) Built-in recording equalizer circuit, and internal switching of the normal/high-speed equalizer is possible.
- 8) All stages are directly connected, so coupling capacitors are not required.
- 9) Muting is applied as required during switching to reduce switching noise (transition muting).
- 10) Pin assignments has been designed to facilitate placement of attached components and PCB design.

●Absolute maximum ratings (Ta = 25°C)

Parameter	Symbol	Limits	Unit
Power supply voltage	Vcc	9	V
Power dissipation	Pd	1250*	mW
Operating temperature	Topr	-25~+75	°C
Storage temperature	Tstg	-55~+125	°C

* Reduced by 12.5mW for each increase in Ta of 1°C over 25°C.

●Recommended operating conditions (Ta = 25°C)

Parameter	Symbol	Limits	Unit
Power supply voltage	Vcc	4.5~7.0	V



● Block diagram

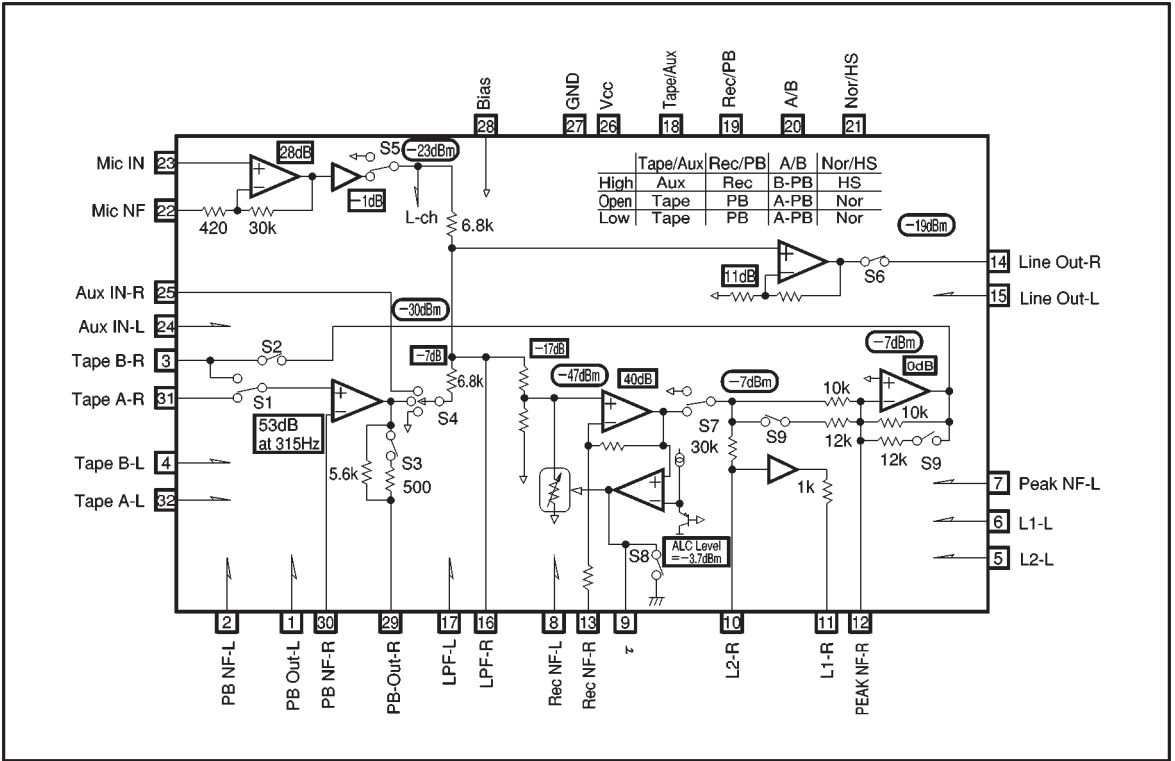

● Pin assignments

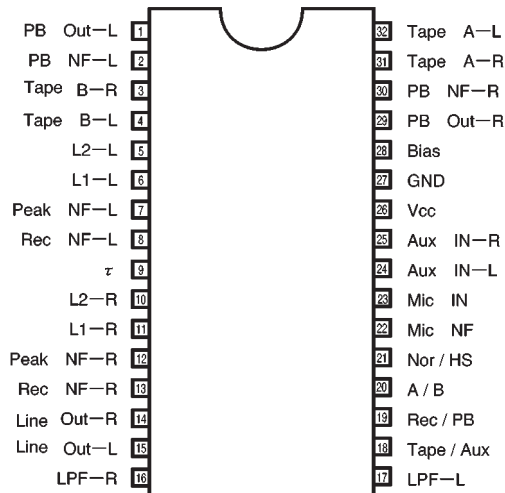

● Pin descriptions

Pin No.	Pin name	Function
1	PB Out—L	Playback equalizer amplifier output (L ch)
2	PB NF—L	Playback equalizer amplifier negative input (L ch)
3	Tape B—R	Tape B input and recording equalizer amplifier output (R ch)
4	Tape B—L	Tape B input and recording equalizer amplifier output (L ch)
5	L2—L	Recording equalizer amplifier active inductor input (L ch)
6	L1—L	Recording equalizer amplifier active inductor output (L ch)
7	Peak NF—L	Recording equalizer amplifier negative input (L ch)
8	Rec NF—L	ALC amplifier negative input (L ch)
9	τ	ALC time constant
10	L2—R	Recording equalizer amplifier active inductor input (R ch)
11	L1—R	Recording equalizer amplifier active inductor output (R ch)
12	Peak NF—R	Recording equalizer amplifier negative input (R ch)
13	Rec NF—R	ALC amplifier negative input (R ch)
14	Line Out—R	Line amplifier output (R ch)
15	Line Out—L	Line amplifier output (L ch)
16	LPF—R	Low-pass filter (R ch)
17	LPF—L	Low-pass filter (L ch)
18	Tape / Aux	Tape/Aux switch control
19	Rec / PB	Record/playback switch control
20	A / B	A mechanism/B mechanism playback switch control
21	Nor / HS	Normal/high-speed mode switch control
22	Mic NF	Microphone amplifier negative input
23	Mic IN	Microphone amplifier input
24	Aux IN—L	Aux input (L ch)
25	Aux IN—R	Aux input (R ch)
26	Vcc	Power supply
27	GND	Substrate ground
28	Bias	Operating reference point and ripple filter
29	PB Out—R	Playback equalizer amplifier output (R ch)
30	PB NF—R	Playback equalizer amplifier negative input (R ch)
31	Tape A—R	Tape A input (R ch)
32	Tape A—L	Tape A input (L ch)

● Input / output circuits

PB EQ Amp

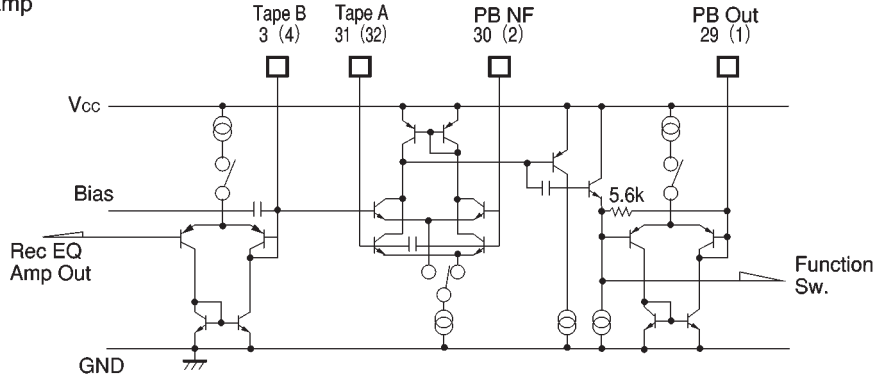

Function Sw

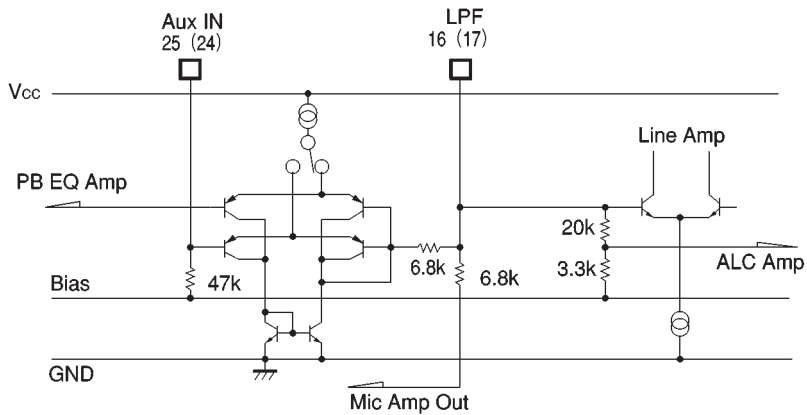

Mic Amp

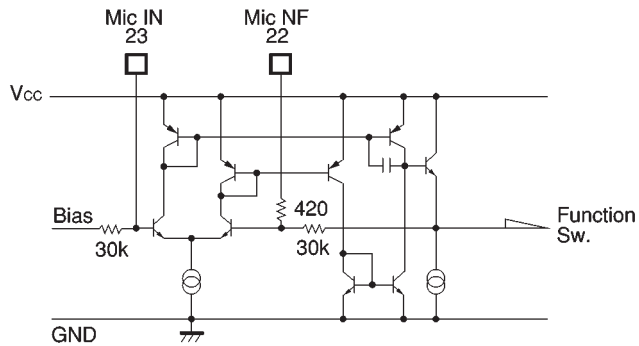

ALC Amp

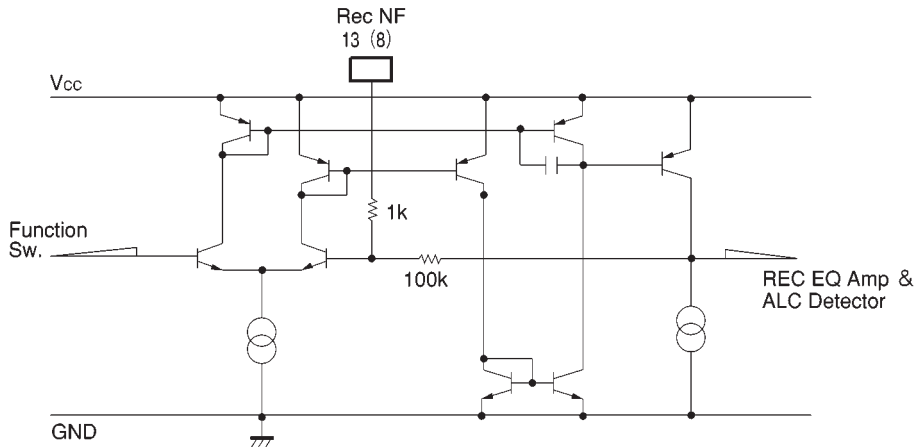

ALC Detector

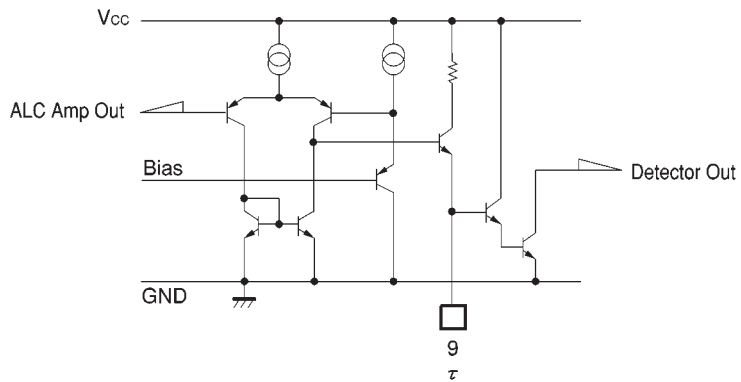

Rec EQ Amp

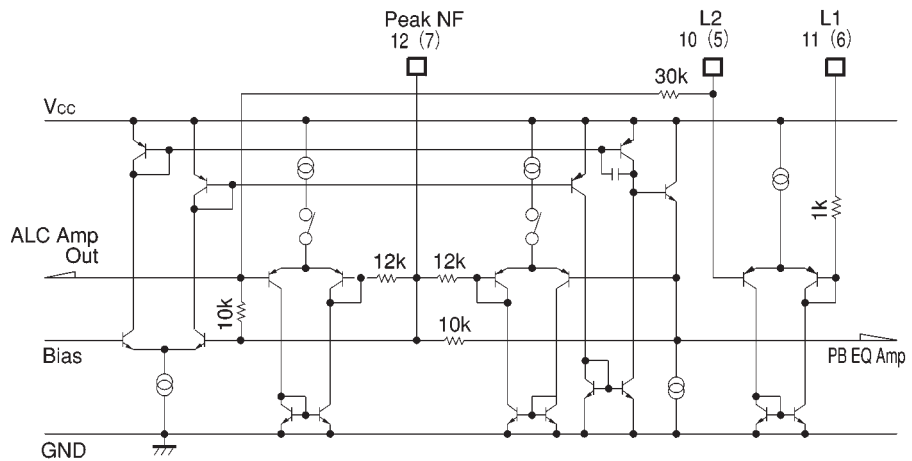

Line Out

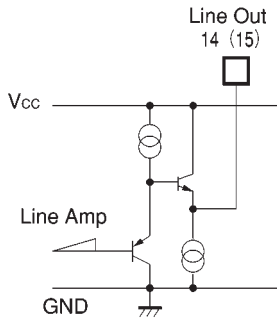

Control

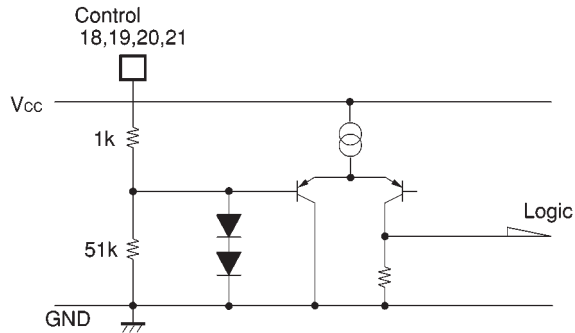

Bias

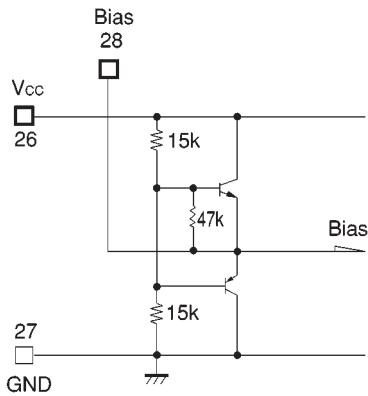

● Electrical characteristics (unless otherwise noted, Ta = 25°C and V_{CC} = 5.5V, f = 1kHz, R_G = 680Ω,
Tape input = -66dB, Mic. input = -50dB, and AUX input = -23dB)

Parameter	Symbol	Min.	Typ.	Max.	Unit	Condition
Quiescent current	I _Q	—	26	39	mA	18~21pin open
Voltage gain						
Mic~Line	G _{vcML}	28	31	34	dB	
Aux~Line	G _{vcAL}	1	4	7	dB	
Aux~Rec	G _{vcAR}	13	16	19	dB	
Tape~Line	G _{vcTL1}	54	57	60	dB	V _{IN} =-76dBm, 315Hz
Tape~Line	G _{vcTL2}	41.6	44	46.4	dB	V _{IN} =-63dB, 10kHz, normal-speed mode (Nor)
Maximum output voltage						Mic input
Line Out	V _{oWL}	2.7	4.7	—	dBm	THD=1%
Rec Out	V _{oWR}	2.5	4.5	—	dBm	THD=3%, ALC OFF
Total harmonic distortion						
Mic ~Line	THD ML	—	0.08	0.5	%	
Aux ~Line	THD AL	—	0.02	0.5	%	High-speed mode (HS)
Aux ~Rec	THD AR	—	0.2	0.7	%	High-speed mode, ALC off
Tape~Line	THD TL	—	0.1	0.7	%	
Input conversion noise voltage (tape)	V _{NIN T}	—	0.8	1.6	μV _{rms}	DIN AUDIO, Line Out, high-speed mode
Output noise voltage (Aux + Mic)	V _{NO AM}	—	60	140	μV _{rms}	DIN AUDIO Line Out
Ripple rejection ratio (during playback)	RR	14	25	—	dB	V _{RR} =-20dBm, f _{RR} =100Hz
Rec EQ amp. gain difference						AUX input
Nor	ΔG _{vcNor}	4.6	7.0	9.4	dB	Measured at 10kHz (output voltage=0dB at f=1kHz)
HS	ΔG _{vcHS}	1.7	3.7	5.7	dB	Measured at 10kHz (output voltage=0dB at f=1kHz)
PB EQ amp. gain difference	ΔG _{vcPB}	3.1	5.5	7.9	dB	Difference between Nor and HS output levels at f=10kHz. Measured at Line Out.
L/R channel separation						
Aux~Line	CS _{LrAL}	55	66	—	dB	V _o =0dBm
Tape~Line	CS _{LrTL}	50	62	—	dB	V _o =0dBm
Aux~Rec	CS _{LrAR}	40	50	—	dB	V _o =0dBm ALC=OFF
A/B crosstalk	CT _{AB}	60	67	—	dB	Measured at Line Out. V _o =0dBm
PB ⇒ REC crosstalk	CT _{RP}	80	92	—	dB	Measured at Rec Out in Rec off state. V _o =0dBm, ALC off, Aux input
Mic mute level	MM	80	92	—	dB	Line Out level difference with HS Sw on / off. V _o =0dBm, AUX mode
ALC distortion	THD _{ALC}	—	0.37	1	%	Mic input=-40dBm, Measured at Rec Out.
ALC level	V _{ALC}	-5.7	-3.7	-1.7	dBm	Mic input=-30dBm, Measured at Rec Out.
ALC balance	CB _{ALC}	—	0	2.5	dB	Mic input=-30dBm, Measured at Rec Out.
ALC current capacity	I _{ALC}	4.0	7.7	—	mA	Mic input=-30dBm, pin 9 output current
Switching control voltage	V _{cT}	4.0	—	V _{CC}	V	Voltage at the other ends of the resistors connected to pins 18 to 21.

* Tape to Aux crosstalk is at or below the noise level when in the Aux playback state

● Explanation of electrical characteristics

Symbol	Description
I_o	DC current flowing into the VCC pin. Measured with all control pins open.
G_{vcML}	Voltage gain from the Mic In pin to the Line Out pin. Measured at $f_{IN} = 1\text{kHz}$, and input voltage = -50dBm .
G_{vcAL}	Voltage gain from the Aux In pin to the Line Out pin. Measured at $f_{IN} = 1\text{kHz}$, and input voltage = -23dBm .
G_{vcAR}	Voltage gain from the Aux In pin to the Rec Out pin. Measured at $f_{IN} = 1\text{kHz}$, and input voltage = -23dBm .
G_{vcTL1}	Voltage gain from the Tape In pin to the Line Out pin. Measured at $f_{IN} = 315\text{Hz}$, and input voltage = -76dBm .
G_{vcTL2}	Voltage gain from the Tape In pin to the Line Out pin. Measured at $f_{IN} = 10\text{kHz}$, input voltage = -63dBm , in normal speed mode.
V_{oML}	Maximum Line Out output voltage. Measured using microphone input, with THD = 1%.
V_{oMR}	Maximum Rec Out output voltage. Measured using microphone input, with ALC off, and THD = 3%.
THD ML	Amplifier distortion from Mic In to Line Out with standard input level.
THD AL	Amplifier distortion from Aux In to Line Out with standard input level. Measurement made in high-speed mode to eliminate effects of amplifier and microphone noise.
THD AR	Amplifier distortion from Aux In to Rec Out with standard input level. Measurement made in high-speed mode to eliminate effects of amplifier and microphone noise.
THD TL	Amplifier distortion from Tape In to Line Out with standard 1kHz input level.
$V_{NIN T}$	Input conversion noise voltage of the tape input stage. To eliminate the effects of microphone noise, amplifier noise, amplifier and recording equalizer treble peaking characteristics, the measurements were made with tape input in high-speed mode at the Line Out pin. The indicated value is the measured noise voltage after passing through a DIN AUDIO filter (20Hz to 20kHz) divided by the gain at $f = 1\text{kHz}$ (47dB).
$V_{No AM}$	Simultaneous measurement of Aux and Mic input noise at the Line Out pin in Aux mode.
RR	Measured at DIN AUDIO with a ripple voltage of $V_{RR} = -20\text{dBm}$ and $f_{RR} = 100\text{Hz}$ applied to the Vcc pin. Measurement made at the Line Out pin in tape playback mode.
ΔG_{vcNor}	Recording equalizer characteristics measurement in normal mode. The value given is the difference in voltage gain from Aux In to Tape B (recording output) for $f = 1\text{kHz}$ and $f = 10\text{kHz}$.
ΔG_{vcHS}	Recording equalizer characteristics measurement in high-speed mode with the same settings as the previous item.
ΔG_{vcPB}	Difference between normal and high-speed mode voltage gain for the playback equalizer measured at Line Out with $f = 10\text{kHz}$.
CS_{LRAL}	Left and right channel separation from Aux In to Line Out. Input the voltage that gives an output of 0dB at Line Out for one Aux In pin, and measure the leakage to the Line Out pin for the Aux In pin that has no input. The result is expressed as a ratio to 0dB.
CS_{LRTL}	Same measurement as above for Tape Input and Line Out
CS_{LRAR}	Left and right channel separation from Aux In to Recording Output. Measurement of the Aux In input voltage that gives an output of 0dB at the Tape B output (recording output) with ALC off (connect τ pin to GND).
CT_{AB}	Measurement of crosstalk between Tape A and Tape B inputs in tape playback mode. Input the voltage that gives an output of 0dB at Line Out to the Tape A pin (or Tape B), and measure the leakage to the Line Out pin in Tape B playback mode (Tape A playback mode). The result is expressed as a ratio to 0dB.
CT_{RP}	Leakage measurement to the recording output in playback mode. In recording mode with ALC off, input a signal to Aux In that gives a 0dB output signal on the Tape B pin (recording output), and measure the recording output voltage when the mode is switched to playback. Expressed as a ratio to 0dB.
MM	Mic Mute level measured in high-speed mode. Input a signal to Mic In that gives a 0dB output signal on the Line Out in normal-speed mode, and measure the Line Out voltage when the mode is switched to high-speed. Expressed as a ratio to 0dB.
THD _{ALC}	Measurement of the distortion from the Mic input to the recording output with ALC operating. The input level is -40dB (standard level = 10dB).
V_{ALC}	Measurement of ALC level at the recording output pin. Measure the recording output voltage at Tape B with ALC fully operating and a Mic input of -30dB (standard level = 20dB).
CB_{ALC}	Balance measurement of the right/left ALC levels. ALC level ratio is expressed as an absolute value in dB with the same measurement conditions as the previous item.
I_{ALC}	Measurement of the output current capacity of the τ pin which determines the ALC attack time. Shows the average value of current output from the τ pin with an input voltage level of -30dB to the Mic input (ALC operating fully).
V_{cT}	Voltage at the ends of the 33k Ω resistors connected to the control pins required to ensure that they are in the "high" state.

● Measurement circuit

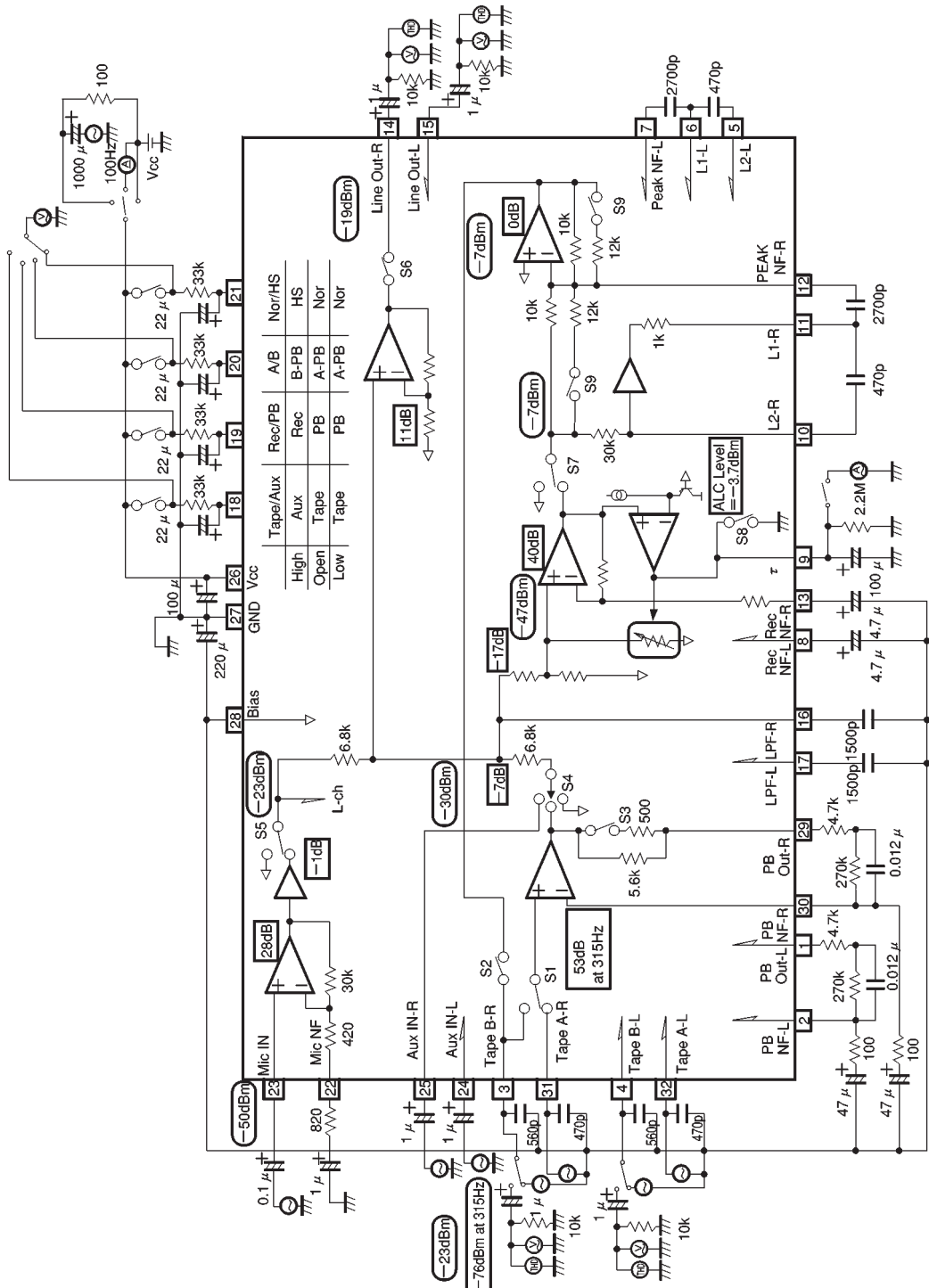

Fig. 1

● Circuit operation

(1) Playback equalizer amplifier

The standard input level is -76dBm at 315Hz . The voltage gain at 315Hz is 53dB , so the standard output level for the playback equalizer amplifier is -23dBm . The playback head is connected between the bias pin (pin 28) and the input pins without coupling capacitors, and the amplifier input stage is biased through the head.

When the A/B switch pin (pin 20) is "H", the input goes to B, and when it is open the input goes to A. The playback equalizer NAB characteristics are determined as follows:

External CR timing circuit: $270\text{k}\Omega$, $4.7\text{k}\Omega$, $0.012\mu\text{F}$

On-chip resistors: $5.3\text{k}\Omega$, 500Ω

Bass time constant:

$$= 270\text{k}\Omega \times 0.012\mu\text{F} \doteq 3180\mu\text{s}$$

Treble time constant:

Normal-speed mode:

$$= (4.7\text{k}\Omega + 5.3\text{k}\Omega) \times 0.012\mu\text{F} = 120\mu\text{s}$$

High-speed mode:

$$= (4.7\text{k}\Omega + 500\Omega) \times 0.012\mu\text{F} = 62.4\mu\text{s}$$

Switching between normal-speed and high-speed modes is controlled by pin 21 (Nor/HS). When pin 21 is HIGH, high-speed mode is selected, and when open, normal-speed mode is selected.

(2) Aux input amplifier

The standard input level is -23dBm , and the input resistance is $47\text{k}\Omega$.

Input the CD or radio signal (or other) via a coupling capacitor. Switch the Tape/Aux input (pin 18) "H" for Aux input mode, and leave it open for tape input mode.

(3) Microphone amplifier

The standard microphone input level is -50dBm when the NF resistor connected to the Mic NF pin (pin 22) is 820Ω . The microphone amplifier gain at this time is 27dB , and the microphone amplifier output is -23dB . The input resistance of the Mic In pin (pin 23) is $30\text{k}\Omega$. Connect the input to pin 23 via a coupling capacitor. The frequency characteristics of the microphone amplifier are determined by the bass cutoff frequency of the CR circuit connected to the Mic NF pin. For treble cutoff, connect a low-pass filter circuit to the input pin.

(4) Function switching (Mic/mixing circuit)

The signal switched by the Tape/Aux switching pin (pin 18) and the microphone amplifier output are mixed by a $6.8\text{k}\Omega$ mixing resistor. However, when the Nor/HS pin is set to high-speed mode ("H"), the microphone amplifier output is muted. When in internal microphone recording mode (only when: pin 18 is open (tape mode), pin 19 is "H" (recording mode), pin 20 is "H" (Tape B mode), and pin 21 is open (normal-speed mode)), the tape and Aux inputs are muted, and only the Mic output is output. If pin 21 is driven "H" (high-speed mode) in this state, all inputs are muted. Pins 16 and 17 are for the low-pass filter. These pins cut bias oscillation leakage during dubbing. The $6.8\text{k}\Omega$ mixing resistor and an external capacitor set the treble cutoff frequency according to the following formula

$$f_{\text{HC}} = 1 / (\pi\text{CR})$$

Treble cutoff frequency: f_{HC} (Hz)

Mixing resistor: $R = 6.8\text{k} (\Omega)$

External capacitor: C (F)

(5) Line amplifier

The standard level of the signal mixed by the mixing resistor is -30dBm . This level is input as is to the line amplifier. The gain of the line amplifier is 11dB , so the standard output is -19dBm , and this is output to the Line Out pins (pins 14 and 15). The line amplifier output has a mute switch, but it is only muted when in internal microphone recording mode (described in the previous item). The line mute operates to suppress the switching "pop" sound that is generated when switching between modes (transient muting). The transient muting time is set by the time constants of the external circuits connected to the control pins (pins 18 to 21). However, in one case only, when pin 18 is "H" (Aux input mode), line output muting does not occur when the other control pins are switched. This is to disable transient line out muting when recording is started while listening to the radio (for example).

(6) ALC amplifier

The -30dBm standard level signal mixed by the mixing resistor enters a -17dB attenuator before the ALC amplifier. This attenuator resistance and an electronic volume are used by the ALC. The ALC amplifier standard input level is -47dBm , and its gain is 40dB , giving a standard output level of -7dBm . The standard output level of the ALC amplifier is compared to the ALC level (-3.7dBm), and if signals above this level are input the ALC operates. The attack and recovery times are determined by the CR circuit connected to the T pin (pin 9).

(7) Recording equalizer amplifier

The standard signal level is -7dBm (from the ALC amplifier output), and has treble peaking characteristic attributed to it by the recording equalizer amplifier. The external capacitors connected between pins 5, 6 and 7, and pins 10, 11 and 12 form an equivalent inductor circuit, and the series impedance of this LCR circuit connected in parallel with the on-chip resistor form the input impedance of the inverting amplifier and give it its peaking characteristic. The equivalent circuit is shown in Fig. 1. If the Nor/HS pin (pin 21) is driven HIGH, the values of the two resistors change, to give the peaking characteristic for high-speed dubbing. In the past, the recording current peaking characteristic was formed by switching the circuit constant values of a fixed-current CR circuit. With the BA3423AS, this is incorporated on the chip. The gain of this stage is 0dB at 1kHz , and the recording output standard level is -7dBm . As the maximum output voltage of the recording output pin (Tape B pins 3 and 4) is 4.5dBm (at $V_{CC} = 5.5\text{V}$), for sudden, large inputs, even during the attack time period until the ALC starts operating, the dynamic range is 4.5dBm - the recording output standard level (-7dBm), i.e. -11.5dBm . This allows low-distortion recording. The frequency response of the recording current flowing through the head is shown in Figs. 17 to 19. This is the response characteristic for fixed input voltage to the Aux In pins (pins 24 and 25). The factors that determine the recording current characteristics are the peaking characteristics of the peaking circuit, and the external fixed-current circuit. The value of the fixed-current circuit resistor (R_0) is calculated using the following formula. The recording output standard level is -7dBm , $f = 1\text{kHz}$, and the standard recording current required is $37\mu\text{A}$ (rms).

$$-7\text{dBm}/(R_H + R_0) = 37\mu\text{Arms}$$

R_H : DC resistance at the head

If R_H is 500Ω , R_0 is approximately $8.2\text{k}\Omega$. The basic values for the capacitors for the external constant-current circuit and recording equalizer amplifier are:

$$C_0 = 820\text{pF}$$

$$C_{L1} \text{ (between pins 6 and 7, and pins 11 and 12)} = 2700\text{pF}$$

$$C_{L2} \text{ (between pins 5 and 6, and pins 10 and 11)} = 470\text{pF}$$

Characteristic curves for different values of C_0 , C_{L1} and C_{L2} are given in Figs. 17, 18 and 19 respectively. Select the values for these components after considering the characteristics of the head to be used, and the overall recording and playback frequency characteristics.

(8) Recording output switch

The Tape B pins (pins 3 and 4) are used as both the B mechanism input pins, and recording output pins, and the recording output switch is used to switch between them. When the input to the Rec/PB pin (pin 19) is "H", recording output is selected, and when it is open, Tape B input is selected. This reduces the complexity of the recording head switch circuitry, and requires just two circuits. Transient muting is used to suppress the "pop" sound that accompanies switching.

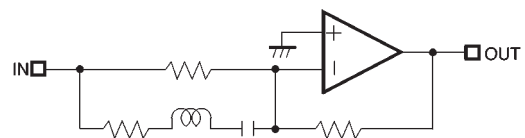

Fig. 2

(9) Control pins

The control pin inputs and the corresponding states of the various inputs and outputs are summarized in the input/output pin status table that follows.

● Input/output pin status

Control pin (Pin No.)			Tape A IN (32, 31)		Tape B IN (4, 3)		Aux IN (24, 25)		Mic IN (23)		Set Condition		
Tape /Aux (18)	Rec/ PB (19)	A/B (20)	Nor/ HS (21)	Line Out (15, 14)	Rec Out (4, 3)	Line Out (15, 14)	Rec Out (4, 3)	Line Out (15, 14)	Rec Out (4, 3)	Line Out (15, 14)		Rec Out (4, 3)	
Tape	PB	A	Nor	●	Open	×	Open	×	Open	●	Open	A PB	
			HS	●HS	Open	×	Open	×	Open	×	Open	(A PB HS)	
		B	Nor	×	Open	●	Open	×	Open	●	Open	B PB	
			HS	×	Open	●HS	Open	×	Open	×	Open	(B PB HS)	
Aux		A	Nor	×	Open	×	Open	●	Open	●	Open	Aux PB	
			HS	×	Open	×	Open	●	Open	×	Open	(Aux PB HS)	
		B	Nor	×	Open	×	Open	●	Open	●	Open	Aux PB	
			HS	×	Open	×	Open	●	Open	×	Open	(Aux PB HS)	
Tape	Rec	A	Nor	●	●	—	—	×	×	●	●	Dubbing	
			HS	●HS	●HS	—	—	×	×	×	×	HS Dubbing	
		B	Nor	×	×	—	—	×	×	×	×	●	Mic Rec
			HS	×	×	—	—	×	×	×	×	×	Mute
Aux		A	Nor	×	×	—	—	●	●	●	●	Aux Rec	
			NS	×	×	—	—	●	●HS	×	×	(Aux Rec HS)	
		B	Nor	×	×	—	—	●	●	●	●	Aux Rec	
			HS	×	×	—	—	●	●HS	×	×	(Aux Rec HS)	

● : Corresponding signal is output.

●HS : Corresponding signal receives the high-speed mode equalizer characteristic and is output.

×

open : In the open (high impedance) state, no signal is output from output pin.

● Application example 1

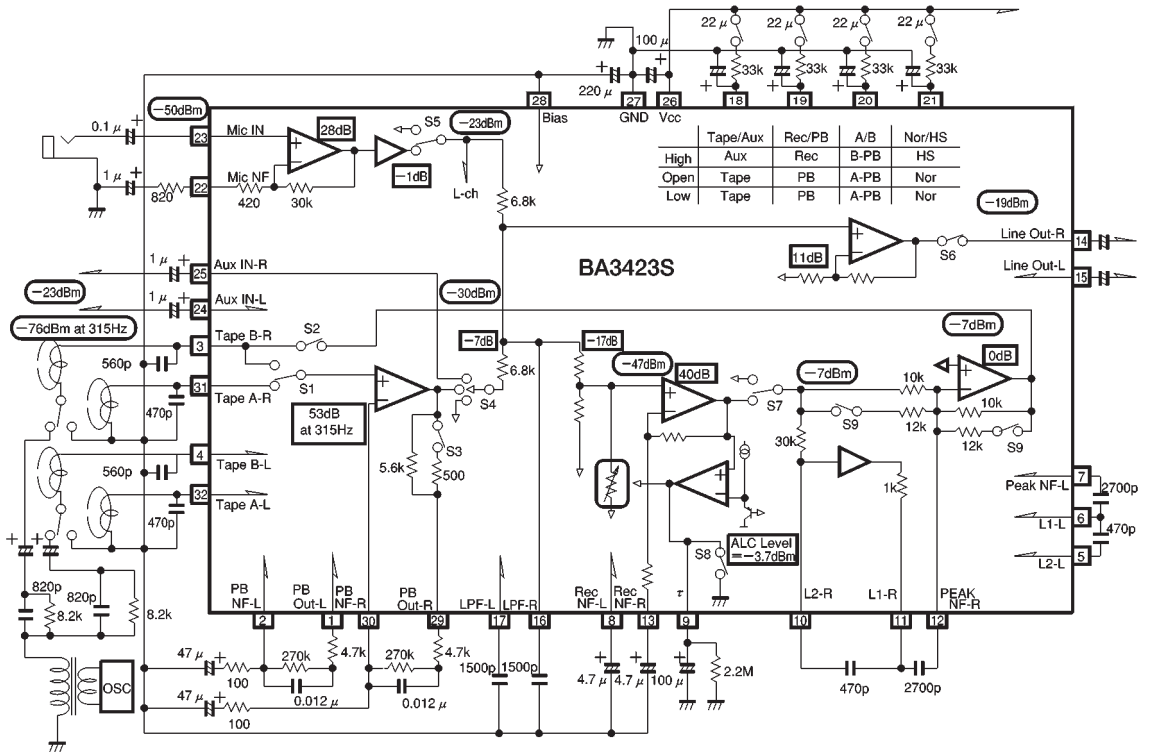

Fig.3

● Application example 2

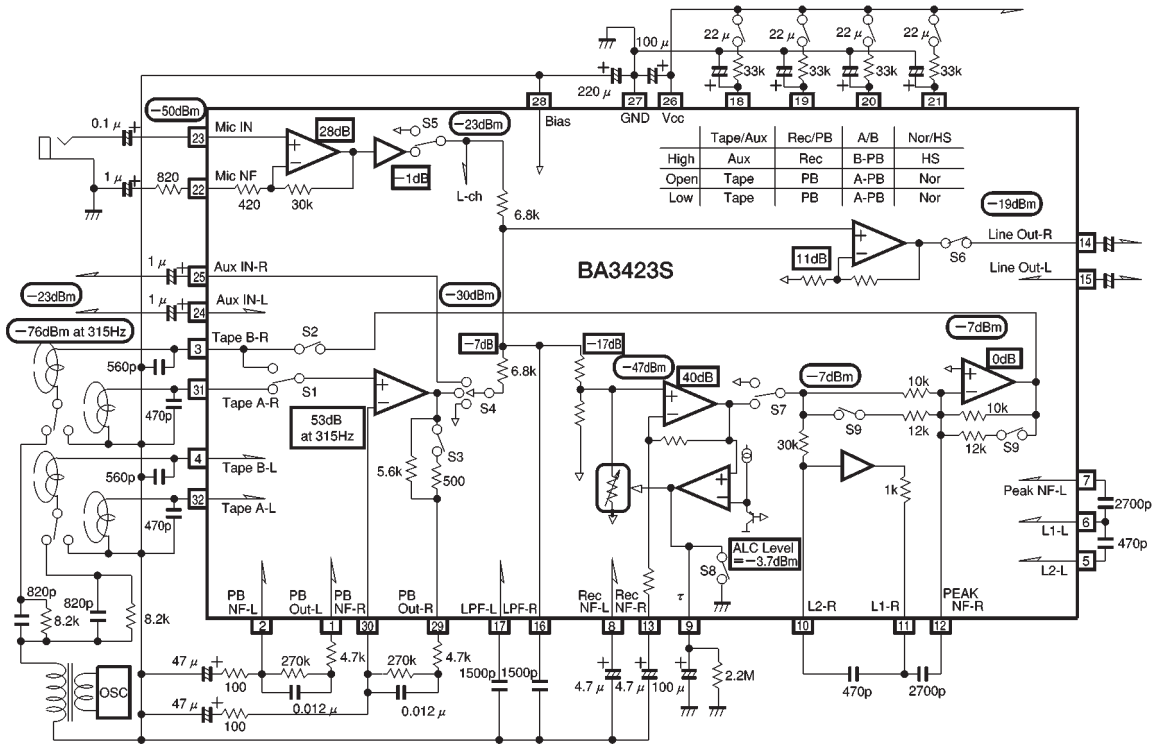

Fig.4

● Application example 3

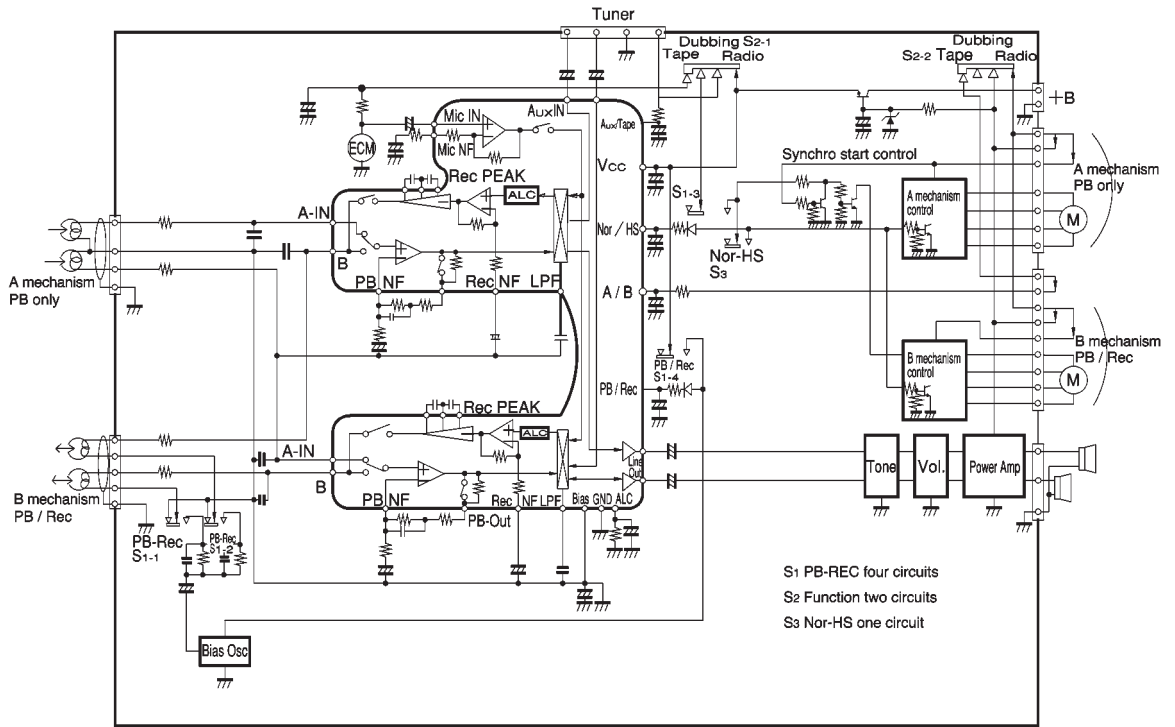

Fig.5

● Operation notes

(1) Amplifier oscillation

As the BA3423S incorporates dual-cassette dubbing functions on a single IC, it has extremely high input/output gain. In particular, in normal-speed mode, the gain at around the recording equalizer peaking characteristic f_0 frequency is about 70dB. The phases of the input and output are reversed to reduce the chance of oscillation due to influence of the PCB pattern, but due consideration must be given to the PCB pattern design to prevent oscillation. In particular, the PCB tracks to the Tape A pins (pins 31 and 32) and Tape B pins (pins 3 and 4) should be sufficiently far apart that there is no coupling capacitance between them, or they should be shielded by having a GND or bias track between them.

(2) Strong RF signals

To prevent signal mixing due to strong electric fields, connect a capacitor (of a few hundred pF) to each input pin. These must be connected close to the pins of the IC to have any effect. Design the PCB track layout so that the capacitors can be connected as close to the base of the pins as possible.

(3) External time constants for the control pins

By keeping the external time constants of the circuits connected to the control pins small, the switching time can be kept low, but as the switching time is reduced, the switching noise increases. Choose the time constants to match the set design. We recommend that you use 33kΩ pullup resistors (these will not effect the maximum output voltage of the recording output).

● Electrical characteristic curves

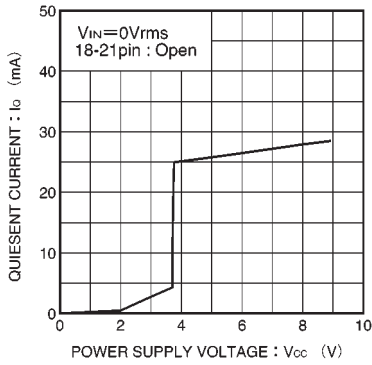

Fig. 6 Quiescent current vs. power supply voltage

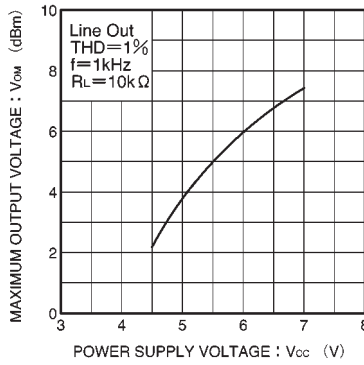

Fig. 7 Maximum output voltage vs. power supply voltage

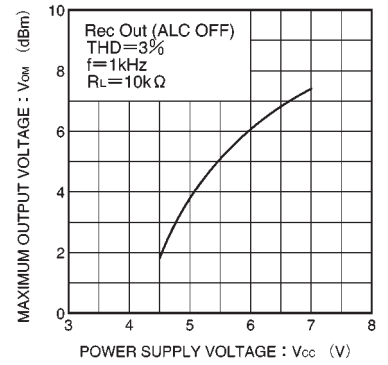

Fig. 8 Maximum output voltage vs. power supply voltage

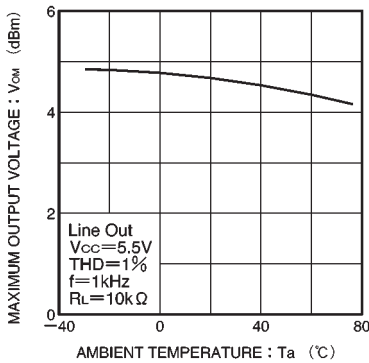

Fig. 9 Maximum output voltage vs. ambient temperature

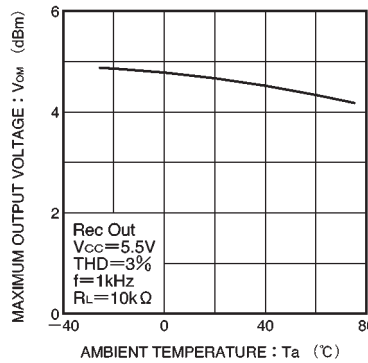

Fig. 10 Maximum output voltage vs. ambient temperature

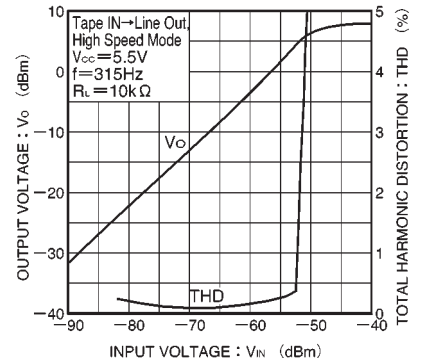

Fig. 11 Output voltage vs. input voltage

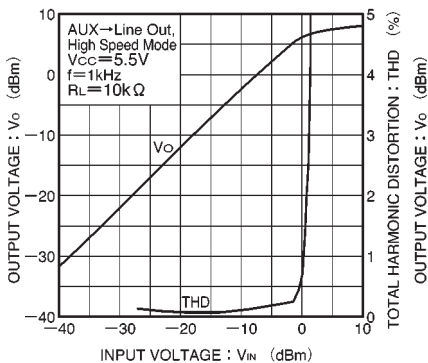

Fig. 12 Output voltage vs. input voltage

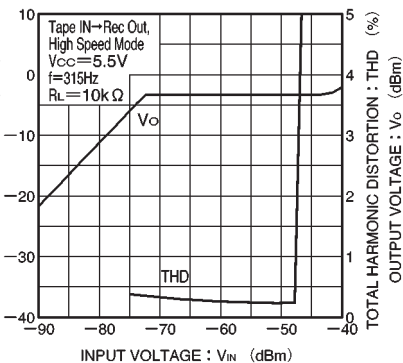

Fig. 13 Output voltage vs. input voltage

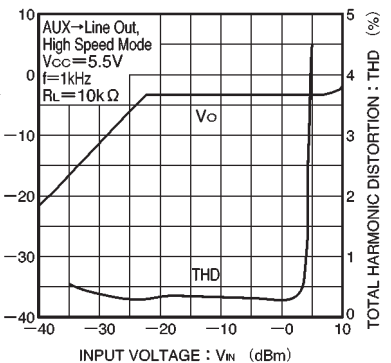

Fig. 14 Output voltage vs. input voltage

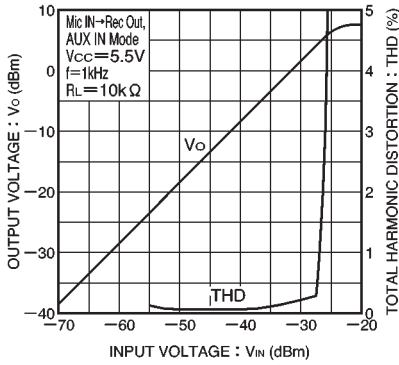

Fig. 15 Output voltage vs. input voltage

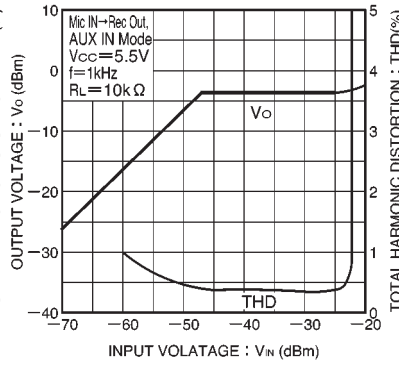

Fig. 16 Output voltage vs. input voltage

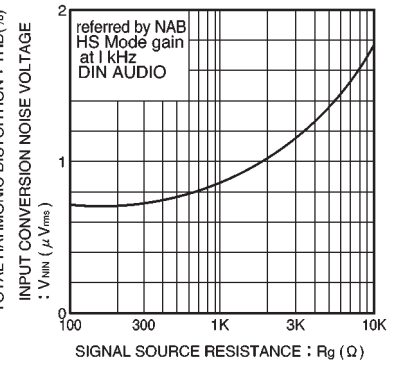

Fig. 17 Input conversion noise voltage vs. signal source resistance

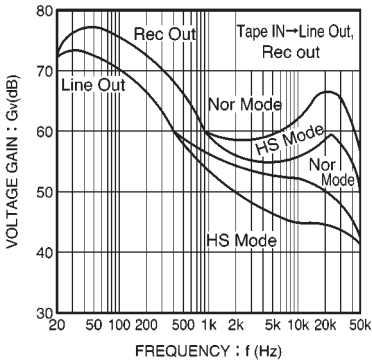

Fig. 18 Voltage gain vs. frequency

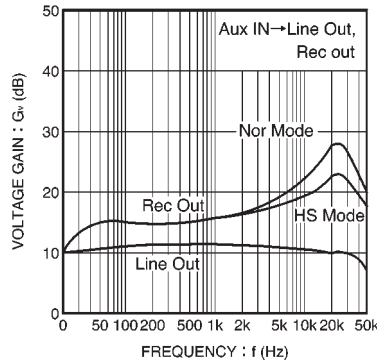

Fig. 19 Voltage gain vs. frequency

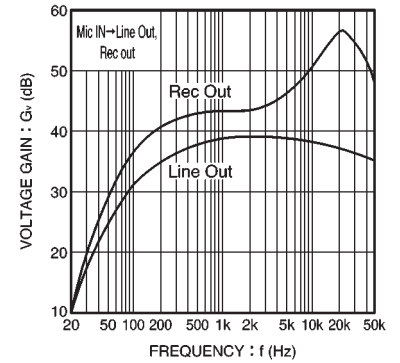

Fig. 20 Voltage gain vs. frequency

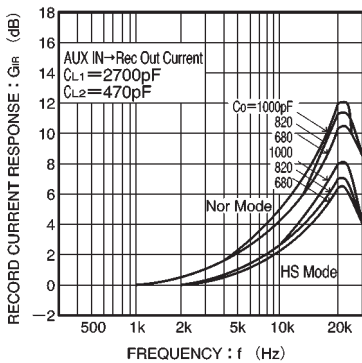

Fig. 21 Recording current response vs. frequency

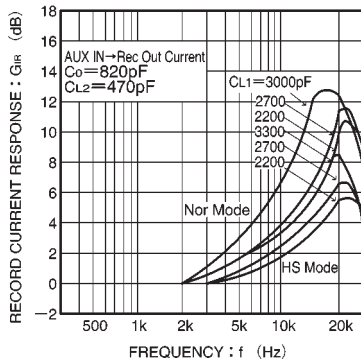

Fig. 22 Recording current response vs. frequency

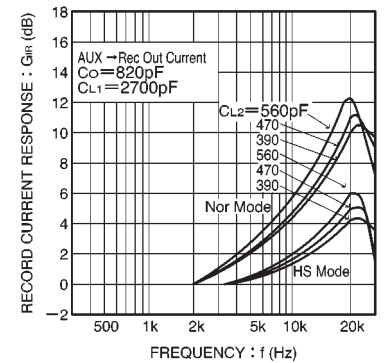

Fig. 23 Recording current response vs. frequency

● External dimensions (Units: mm)

