

3V / 35mW dual power amplifier

BA5204F

The BA5204F is a dual-channel power amplifier designed for 3V stereo headphone tape players. There is almost no "pop" sound generated when the power is switched on and off, so this IC is ideal for headphone applications. Input coupling capacitors are not required, and only one filter capacitor is needed which helps reduce set size. In addition to operating off low voltage, the IC has low distortion, making it suitable for Hi-Fi applications. The circuit can operate down to 1.5V, and has excellent ripple rejection ratio, so it is not adversely influenced by the motor or tape transport systems.

●Applications

3V compact cassette headphone stereos players, micro cassette players, and FM stereo radios

●Features

- 1) Rated output of 35mW ($R_L = 32\Omega$) off a 3V power supply.
- 2) Low "pop" noise when power is switched on and off.
- 3) Low quiescent current (13mA).
- 4) Excellent ripple rejection ratio (38dB).
- 5) Begins operating at 1.5V.
- 6) Low distortion (0.05% at $P_o = 5mW$).
- 7) Good voltage gain balance between channels.
- 8) Good channel separation (60dB Typ.).
- 9) Input coupling capacitors not required.
- 10) Symmetrical pin assignments facilitates PCB design.

●Block diagram

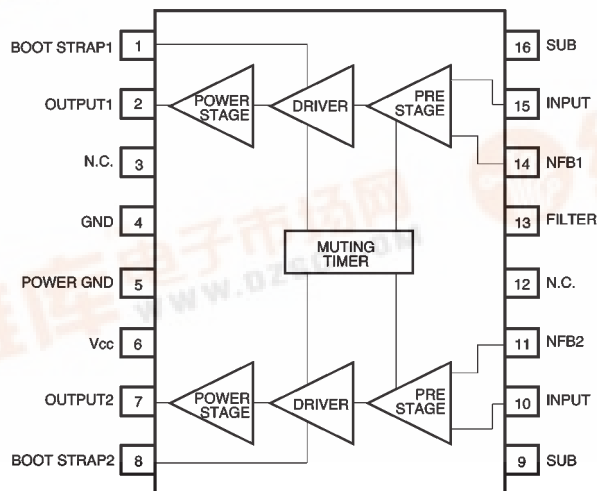

● Internal circuit configuration

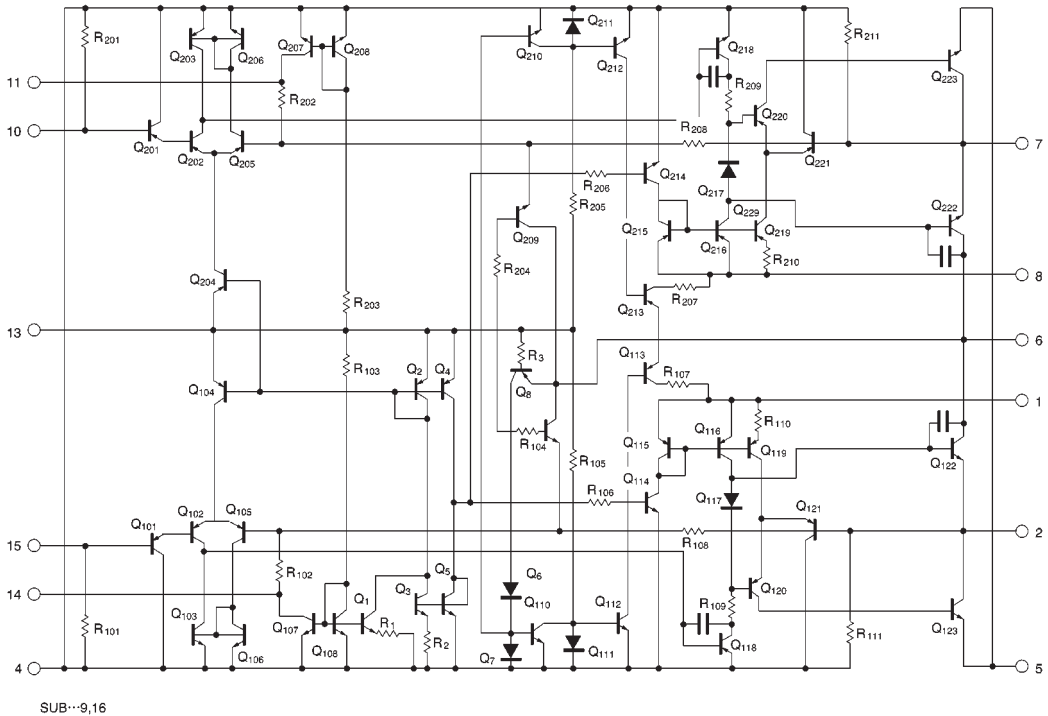

● Circuit description (refer to the Internal Circuit diagram)

(1) Preamplifier Stage

The preamplifier is comprised of the level-shift transistor Q₁₀₁, a differential amplifier (Q₁₀₂ and Q₁₀₅), and the active load (Q₁₀₃ and Q₁₀₆). The input is a PNP transistor that does not require a coupling capacitor.

(2) Pre-drive stage

Q₁₁₈ is the pre-drive transistor. Q₁₂₂ and Q₁₂₀ form the load.

(3) Power stage

Comprised of phase-inverting transistor Q₁₂₀, and power transistors Q₁₂₂ and Q₁₂₃.

(4) Idling current setting circuit

The idling current is controlled so that the difference between the V_{BE} of the power transistor Q₁₂₂ and the V_{BE} of the phase-inverting transistor Q₁₂₀ is the same as the difference between the V_F of the constant-voltage diode Q₁₁₇ and the V_{BE} of Q₁₂₁.

(5) Negative-feedback circuit

The closed-circuit gain with negative feedback is determined by R₁₀₈, R₁₀₂, and the value of the resistor connected to the NFB pin. Part of the gain setting resistance is on the chip (R₁₀₂) to reduce variance between components.

(6) "Pop" noise elimination circuit

The IC has an internal timing circuit (with switch for operation) to reduce the "pop" noise that occurs when power is applied.

● Absolute maximum ratings ($T_a = 25^\circ\text{C}$)

Parameter	Symbol	Limits	Unit
Power supply voltage	Vcc	6.0	V
Power dissipation	Pd	500*	mW
Operating temperature	Topr	-25~+75	°C
Storage temperature	Tstg	-55~+125	°C
Junction temperature	Tj	125	°C

* Reduced by 5.0mW for each increase in T_a of 1°C over 25°C (when mounted on a 70mm×70mm×1.6mm glass epoxy board).

● Electrical characteristics ($T_a = 25^\circ\text{C}$, $V_{cc} = 3\text{V}$, $f = 1\text{kHz}$ and $R_L = 32\Omega$)

Parameter	Symbol	Min.	Typ.	Max.	Unit	Conditions
Quiescent current	I _Q	—	13	20	mA	V _{IN} =0V _{rms}
Closed loop voltage gain	G _{VC}	32	35	38	dB	V _{IN} =-45dBm
Rated output power	P _{OUT}	23	35	—	mW	THD=10%
Distortion	THD	—	0.05	0.3	%	P _O =5mW
Output noise voltage	V _{NO}	—	80	200	μV _{rms}	R _g =0Ω, G _{VC} =35dB B.P.F.20Hz~20kHz
Input resistance	R _{IN}	2.0	30	—	kΩ	
Ripple rejection ratio	RR	28	38	—	dB	V _{RR} =-20dBm, f=100Hz, R _g =0Ω
Operation start voltage	V _s	—	1.5	1.8	V	

● Measurement circuit

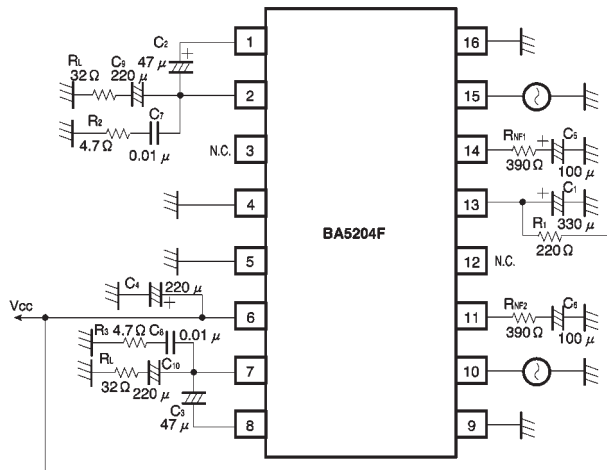

Fig. 1

● Application example

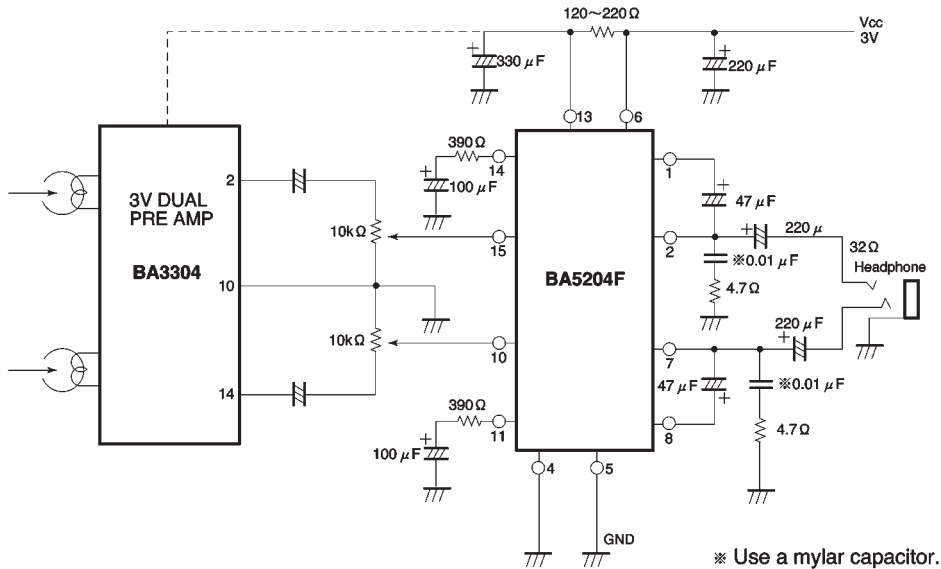

Fig. 2

● Attached components (Fig. 15)

C₁: filter capacitor

The recommended value is 330μF. If this is reduced too much, the ripple rejection ratio will drop. This capacitor also sets the muting time when power is applied. Reduce the value of this capacitor if you wish to shorten the start-up time. On the other hand, if you wish to reduce the “pop” noise further, increase the value of this capacitor to lengthen the startup time.

C₂ and C₃: bootstrap capacitors

The recommended value is 47μF. If the capacitance is too small, the IC will not be able to produce its rated power in the bass region and distortion will increase.

C₅ and C₆: feedback circuit DC blocking capacitors

These capacitors and R_{NF} set the bass cutoff frequency.

$$ch_1 \cdots f_{LC1} = \frac{1}{2\pi \cdot C_5 \cdot (R_{NF1} + R_{102})}$$

$$ch_2 \cdots f_{LC2} = \frac{1}{2\pi \cdot C_6 \cdot (R_{NF2} + R_{202})}$$

R_{NF1} and R_{NF2} determine the amount of feedback for the feedback circuit. These resistors determine the closed-circuit voltage gain (G_{VC}).

C₇ and C₈: depending on the PCB design, and output circuit wiring, feedback may be applied to the IC’s internal circuits and cause high-frequency oscillation. These capacitors prevent this from happening. They also increase the amount of design freedom with regard to the output wiring and PCB artwork. Design the PCB so that the length of the wiring from ch1 and ch2 to capacitors and from the capacitors to GND is as short as possible. Mylar capacitors of about 0.01μF are appropriate for this application, although active capacitors may also be used. The residual impedance and resonant frequency will differ depending on the type of capacitor and therefore have some influence on the effectiveness.

C₉ and C₁₀: output coupling capacitors

The recommended value is 220μF. If the capacitance is too small, the IC will not be able to produce its rated power in the treble region and distortion will increase.

● Electrical characteristics curves

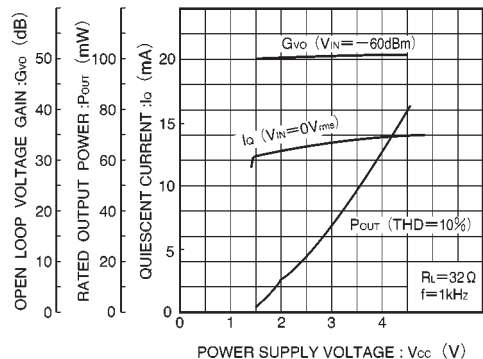
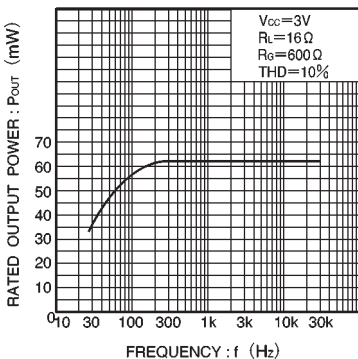
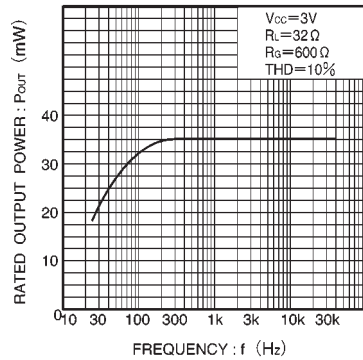
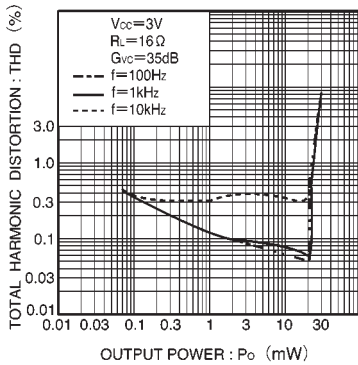
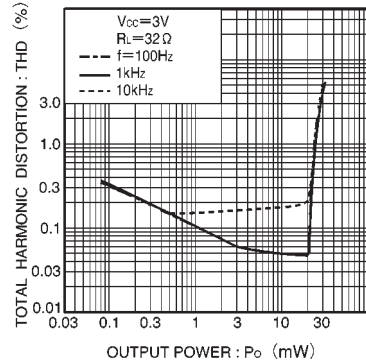
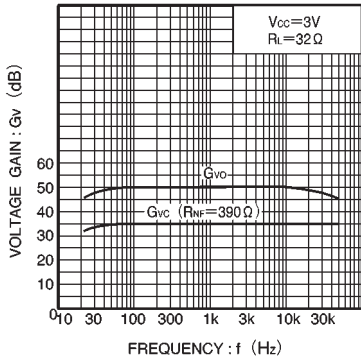

Fig. 7 Rated output power vs. frequency

Fig. 8 Open loop voltage gain/quiescent current/rated output power vs. power supply voltage

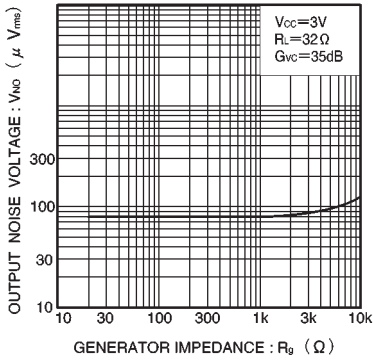

Fig. 9 Output noise voltage vs. signal source impedance

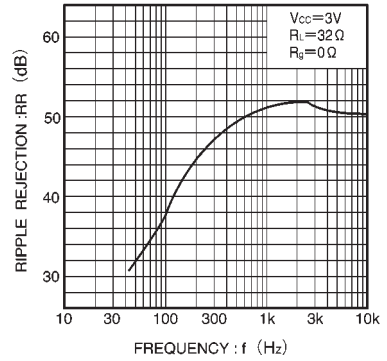

Fig. 10 Ripple rejection ratio vs. frequency

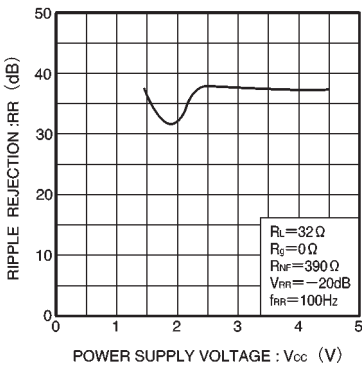

Fig. 11 Ripple rejection ratio vs. power supply voltage

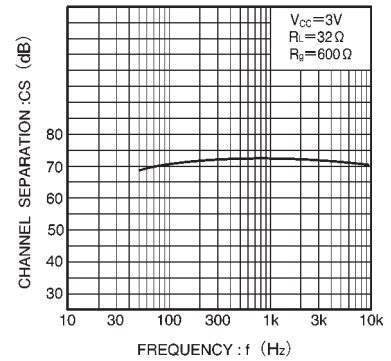

Fig. 12 Channel separation vs. frequency

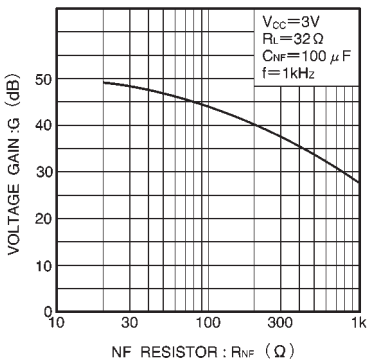

Fig. 13 Voltage gain vs. feedback resistor value

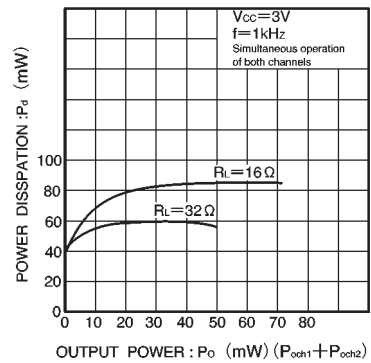

Fig. 14 Power dissipation vs. output power

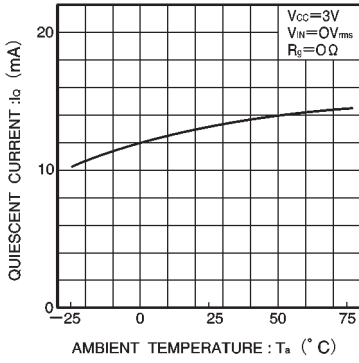

Fig. 15 Quiescent current vs. ambient temperature

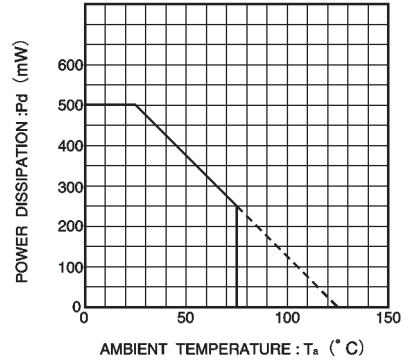

Fig. 16 Thermal derating curve

● External dimensions (Units: mm)

