

5-channel high current driver BA612

The BA612 is a high-current driver IC, and contains an array of five Darlington transistors, each with input resistance. Input and output can be directed in the same direction using DIP Pin 14, with the layout optimized to facilitate mounting.

●Applications

Hammer solenoid drivers
Relay drivers
LED drivers

●Features

- 1) 5-circuit Darlington transistor array.
- 2) Large current (up to 400mA) can be driven.
- 3) Input and output pins are aligned in the same direction, for easy mounting.
- 4) High current transfer ratio.
- 5) Can be coupled with MOS ICs.

●Block diagram

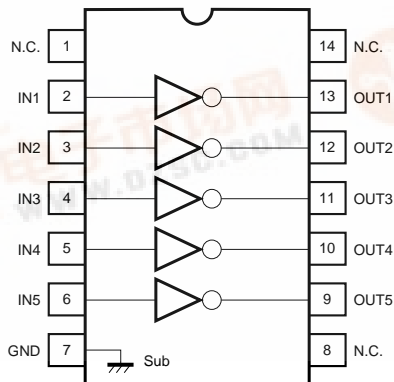

● Absolute maximum ratings (Ta = 25°C)

| Parameter | Symbol | Limits | Unit |
|--------------------------------------|------------------|--------------|------|
| Power supply voltage | V _{CC} | 24 | V |
| Power dissipation | P _d | 550* | mW |
| Operating temperature | T _{opr} | - 25 ~ + 75 | °C |
| Storage temperature | T _{stg} | - 55 ~ + 125 | °C |
| Collector current | I _c | 450 | mA |
| Input pin voltage withstanding (+) | V _{IN+} | 24 | V |
| Input pin voltage withstanding (-) | V _{IN-} | - 0.5 | V |

* Reduced by 5.5mW for each increase in Ta of 1°C over 25°C

● Internal circuit configuration

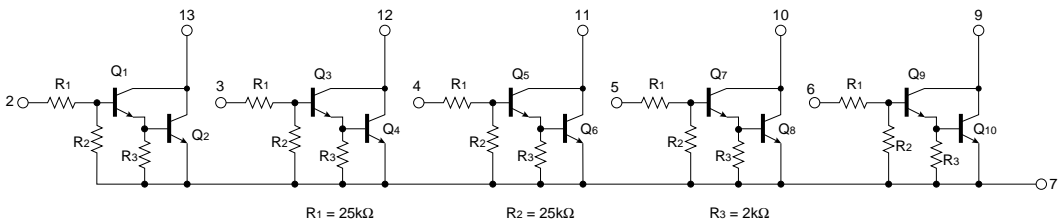

Fig.1

● Electrical characteristics (unless otherwise noted, Ta = 25°C)

| Parameter | Symbol | Min. | Typ. | Max. | Unit | Conditions | Measurement circuit |
|------------------------------|----------------------|------|-------|------|------|---|---------------------|
| Usage voltage range | V _{CC} | — | — | 20 | V | — | — |
| Output leakage current | I _L | — | — | 100 | μA | V _{CC} = 26V, V _{IN} = 0V | Fig.10 |
| Output current (1 circuit) | I _{OUT} | — | — | 400 | mA | When only 1 circuit is on | Fig.11 |
| Output current (5 circuits) | I _{OUT} | — | Fig.3 | — | — | DC per circuit when all 5 circuits are on at once | — |
| Collector saturation voltage | V _{CE(sat)} | — | — | 2.0 | V | I _{OUT} = 400mA, V _{IN} = 17V | Fig.11 |
| DC current transfer ratio | h _{FE} | 2000 | — | — | — | — | — |
| Input current | I _{IN} | — | 0.6 | 1.0 | mA | V _{IN} = 17V, I _{OUT} = 0mA | Fig.11 |

●Electrical characteristic curves

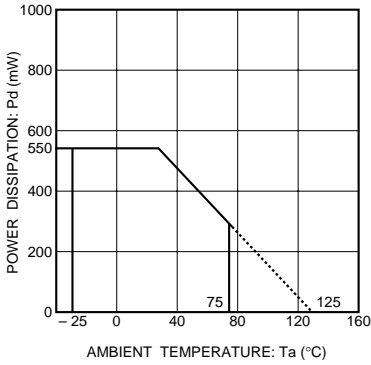

Fig.2 Power dissipation vs. ambient temperature

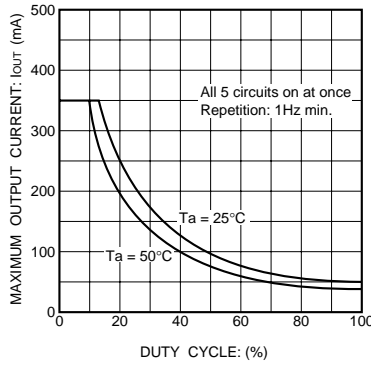

Fig.3 Output current vs. duty cycle

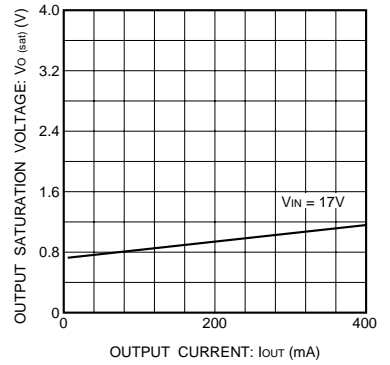

Fig.4 Output saturation voltage vs. output current

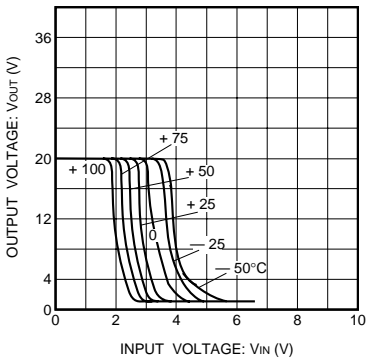

Fig.5 Output voltage vs. input voltage (temperature characteristic)

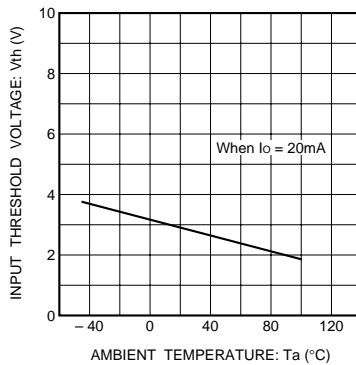

Fig.6 Input threshold voltage vs. ambient temperature

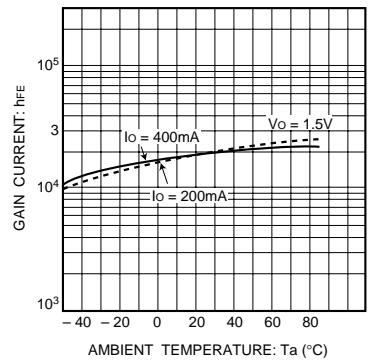

Fig.7 DC current amplification ratio vs. ambient temperature (I) (when $V_o = 1.5V$)

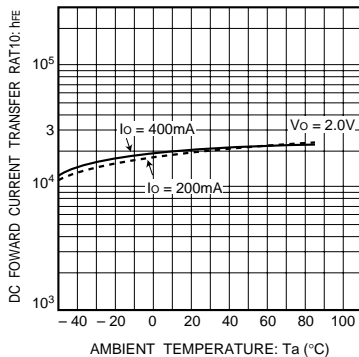

Fig.8 DC current amplification ratio vs. ambient temperature (II) (when $V_o = 2V$)

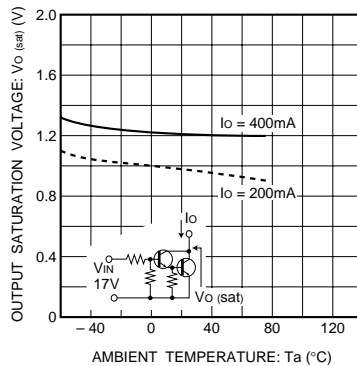

Fig.9 Output saturation voltage vs. ambient temperature

●Measurement circuit

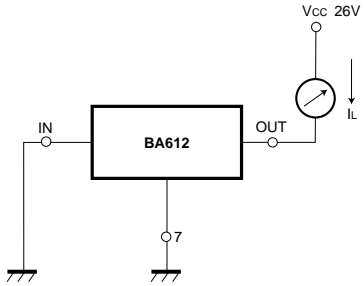

Fig.10

●Application example

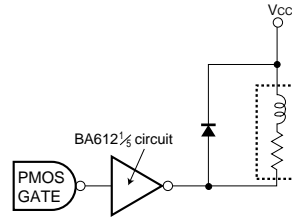

Fig.12

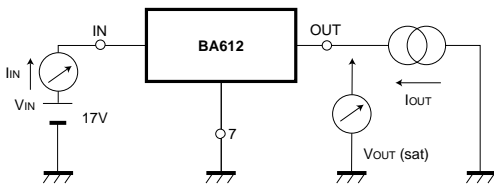

Fig.11

Connections should be made as shown in Figure 12 if inductive load is being driven.

A clamp diode has to be added in series with the load to suppress surges in the inductive load.

●External dimensions (Units: mm)

