

# Reversible motor driver

## BA6229

The BA6229 is a monolithic IC used for driving reversible motors. The ICs contain a logic section by which brake and open modes can be set and an output power transistor by which forward and reverse operations are controlled.

### ●Features

- 1) Built-in power transistor for motor driving (1.2A Max.).
- 2) Low quiescent current. ( $V_{CC}=12V$ ,  $I_Q=1mA$ )
- 3) Wide range of operating supply voltage (8 ~ 23V).
- 4) Interfaces with CMOS devices.
- 5) Four output modes: forward, reverse, stop (open), and brake.
- 6) Built-in diode absorbs surge currents.

### ●Block diagram

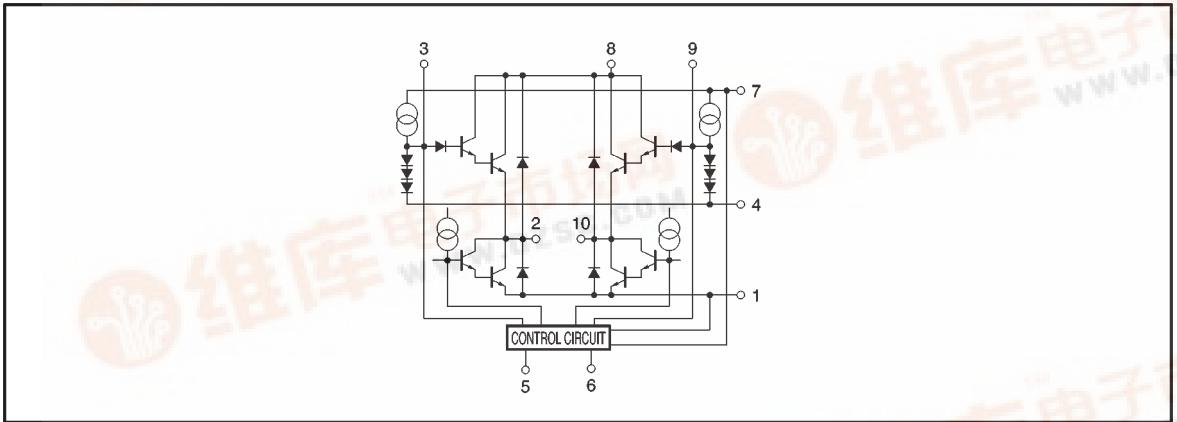

### ●Absolute maximum ratings ( $T_a = 25^\circ C$ )

Parameter	Symbol	Limits	Unit
Power supply voltage	$V_{CC}$	24	V
Power dissipation	$P_d$	2.2*1	W
Operating temperature	$T_{opr}$	-25~+75	$^\circ C$
Storage temperature	$T_{stg}$	-55~+125	$^\circ C$
Output current	$I_{OUT}$	1.2*2	A
Input voltage	$V_{IN}$	-0.3~ $V_{CC}$	V

\*1 Reduced by 22mW for each increase in  $T_a$  of  $1^\circ C$  over  $25^\circ C$ .

\*2 500  $\mu s$  pulse with a duty ratio of 1%.

● Measurement circuit

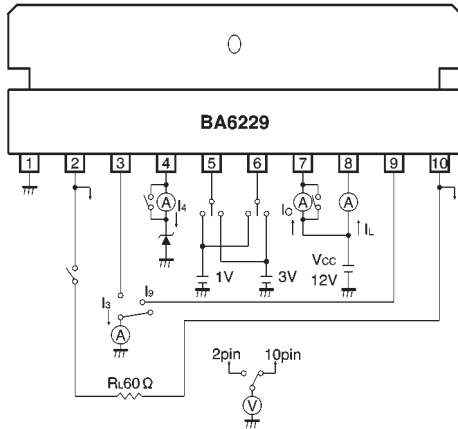

Fig.1

● Application example

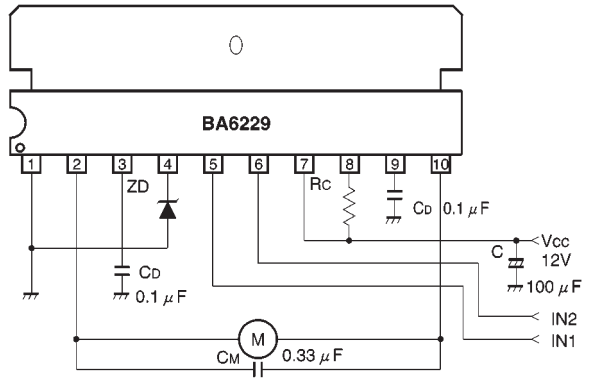

Fig.2

● Electrical characteristics (unless otherwise noted, Ta = 25°C and VCC1 = 12V)

Parameter	Symbol	Min.	Typ.	Max.	Unit	Conditions
Operating voltage 1	VCC1	8.0	—	23	V	
Operating voltage 2	VCC2	8.0	—	23	V	
Quiescent current	I0	—	1	3	mA	RL=∞
Input threshold voltage of pins 5 and 6	VT	1	2	3	V	RL=∞
Output high level voltage for pins 2 and 10	VH	6.5	7.0	8.0	V	RL=60Ω, pin5=“L”, pin6=“H” pin5=“H”, pin6=“L”
Output low level voltage for pins 2 and 10	VL	—	0.8	1.2	V	RL=60Ω, pin5=“L”, pin6=“H” pin5=“H”, pin6=“L”
Output leakage current	IL	—	—	500	μA	Current flowing into pin 8 when pins 5 and 6 are both HIGH or both LOW
Pin-4 bias current	I4	0.3	0.7	1.8	mA	RL=60Ω
Constant current of pins 3 and 9	I3, I9	0.4	0.8	2	mA	pin6=“H”, pin9=GND pin5=“H”, pin3=GND

## ●Operation notes

(1) The quality of these products have been carefully checked; however, use of the products with applied voltages, operating temperatures, or other parameters that exceed the absolute maximum rating given may result in the damage of the IC and the product it is used in. If the IC is damaged, the short mode and open modes cannot be specified, so if the IC is to be used in applications where parameters may exceed the absolute maximum ratings, then be sure to incorporate fuses, or other physical safety measures.

### (2) Input pins

Voltage should never be applied to the input pins when the  $V_{CC}$  voltage is not applied to the IC. Similarly, when  $V_{CC}$  is applied, the voltage on each input pin should be less than  $V_{CC}$  and within the guaranteed range for the electrical characteristics.

### (3) Back-rush voltage

Depending on the ambient conditions, environment, or motor characteristics, the back-rush voltage may fluctuate. Be sure to confirm that the back-rush voltage will not adversely affect the operation of the IC.

### (4) Large current line

Large currents are carried by the motor power supply and motor ground for these ICs.

Therefore, the layout of the pattern of the PC board and the constants of certain parameters for external components, such as the capacitor between the power supply and ground, may cause this large output current to flow back to the input pins, resulting in output oscillation or other malfunctions. To prevent this, make sure that the PC board layout and external circuit constants cause no problems with the characteristics of these ICs.

### (5) Power dissipation

The power dissipation will fluctuate depending on the mounting conditions of the IC and the ambient environment. Make sure to carefully check the thermal design of the application where these ICs will be used.

### (6) Power consumption

The power consumption by the IC varies widely with the power supply voltage and the output current. Give full consideration to the power dissipation rating and the thermal resistance data and transient thermal resistance data, to provide a thermal design so that none of the ratings for the IC are exceeded.

### (7) ASO

Make sure that the output current and supply voltage do not exceed the ASO values.

### (8) Precautions for input mode switching

To ensure reliability, it is recommended that the mode switching for the motor pass once through the open mode.

### (9) In-rush current

There are no circuits built into these ICs that prevent in-rush currents. Therefore, it is recommended to place a current limiting resistor or other physical countermeasure.

### (10) Factors regarding the thermal, power supply, and motor conditions

If the potential of the output pin sways greatly and goes below the potential of ground, the operation of the IC may malfunction or be adversely affected. In such a case, place a diode between the output and ground, or other measure, to prevent this.

## ●External dimensions (Units: mm)

