

6-channel inverter

BA6266 / BA6266F

The BA6266 and BA6266F are driver ICs featuring high output voltage capability and high-current open collector output, and having six built-in inverter buffer circuits.

The open collector output enables “AND” ties. In addition, clamp diodes are connected to all inputs, minimizing error caused by ringing and other factors. These inverters feature a high output pressure withstand resistance of 30V, as well as a large output power supply (sink current) of 40mA, making them suitable for use in LED drivers and interfaces with other elements.

●Applications

General-purpose digital equipment

●Features

- 1) High output current. ($I_{OL} = 40\text{mA}$)
- 2) High output voltage. ($V_O = 30\text{V}$)
- 3) “AND” ties enabled.
- 4) Wide range of operating temperatures.

●Block diagram

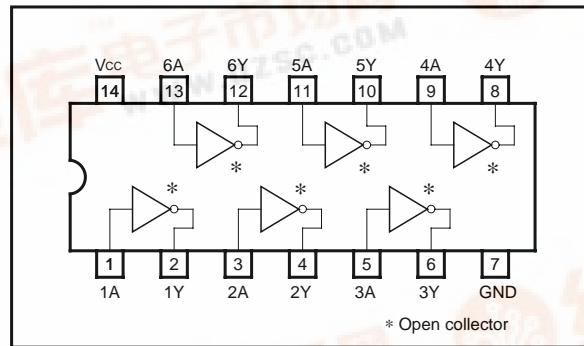

●Absolute maximum ratings ($T_a = 25^\circ\text{C}$)

Parameter	Symbol	Limits	Unit
Power supply voltage	V_{CC}	7	V
Power dissipation	BA6266	600*1	mW
	BA6266F	550*2	
Operating temperature	T_{opr}	0 ~ +70	$^\circ\text{C}$
Storage temperature	T_{stg}	-55 ~ +125	$^\circ\text{C}$
Input voltage	V_i	5.5	V
Output voltage	V_o	33	V

*1 Reduced by 6.0mW for each increase in T_a of 1°C over 25°C .

*2 Reduced by 5.5mW for each increase in T_a of 1°C over 25°C .

●Recommended operating conditions ($T_a = 25^\circ\text{C}$, $V_{CC} = 5\text{V}$)

Parameter	Symbol	Min.	Typ.	Max.	Unit	Conditions
Power supply voltage	V_{CC}	4.75	5	5.25	V	—
Output voltage	V_o	—	—	30	V	When output is "H"

●Electrical characteristics (unless otherwise noted, $T_a = 25^\circ\text{C}$, $V_{CC} = 5\text{V}$)

Parameter	Symbol	Min.	Typ.	Max.	Unit	Conditions
Input high level voltage	V_{IH}	2	—	—	V	—
Input low level voltage	V_{IL}	—	—	0.8	V	—
Output saturation voltage 1	V_{OL1}	—	—	0.4	V	$V_{CC} = 4.75\text{V}$, $I_{OL} = 16\text{mA}$
Output saturation voltage 2	V_{OL2}	—	—	0.7	V	$V_{CC} = 4.75\text{V}$, $I_{OL} = 40\text{mA}$

●Internal equivalent circuit diagram

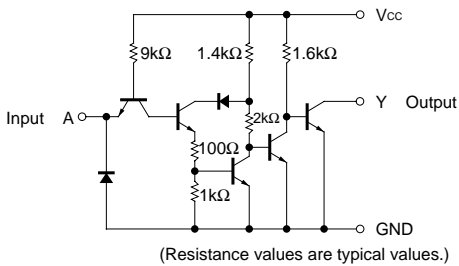

Fig.1

●Truth table

A	Y
H	L
L	H

●Application examples

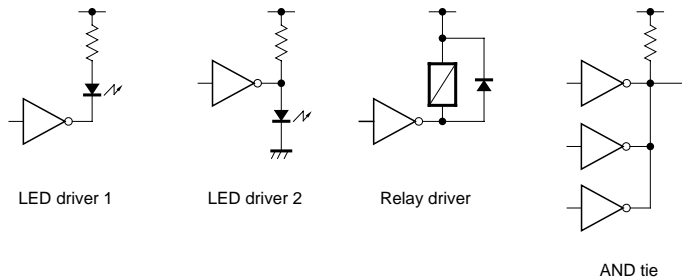

Fig.2

●Electrical characteristics curves

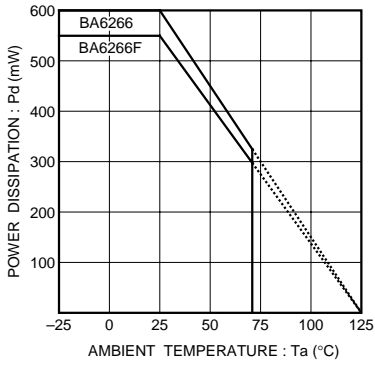

Fig.3 Power dissipation vs. ambient temperature

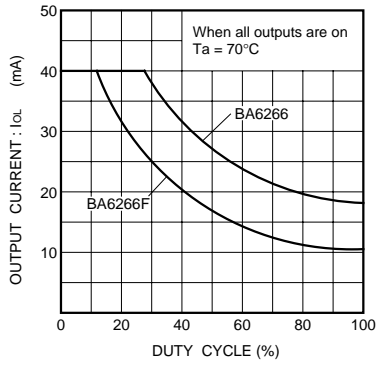

Fig.4 Output conditions diagram

●External dimensions (Units: mm)

