

2-phase half-wave motor predriver

BA6402F

The BA6402F is a 2-phase, half-wave motor predriver suitable for fan motors.

●Features

- 1) Lock detection and rotational speed sensing mechanisms are built in.
- 2) Hall constant current source is built in.
- 3) Compact 8-pin SOP package reduces the number of external components required.

●Block diagram and application example

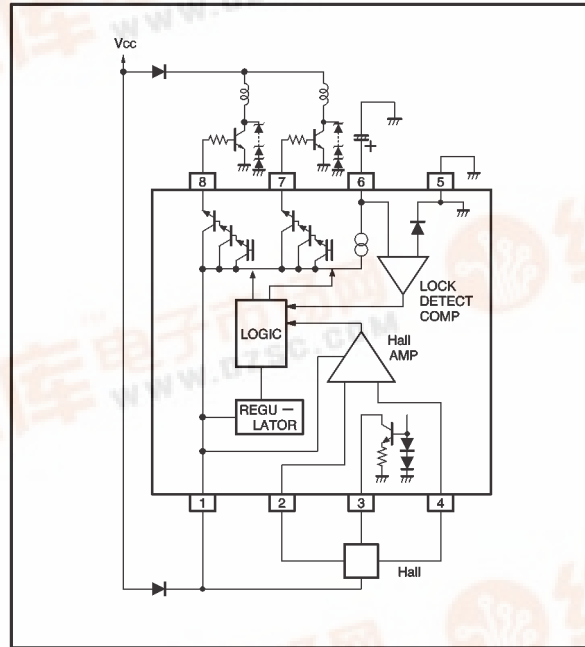

●Absolute maximum ratings (Ta = 25°C)

Parameter	Symbol	Limits	Unit
Applied voltage	V _{CC}	30	V
Power dissipation	P _d	450*	mW
Operating temperature	T _{opr}	-20~+80	°C
Storage temperature	T _{stg}	-55~+125	°C
Output current	I _{OMax}	70	mA

*Reduced by 4.5 mW for each increase in Ta of 1°C over 25 °C.

●Recommended operating conditions

Parameter	Symbol	Min.	Typ.	Max.	Unit	Conditions
Applied voltage	V _{CC}	4	—	28	V	Operate within the allowable power dissipation for -20°C < Ta < 80°C
Input voltage	V _{BH}	0.8	—	V _{CC} -0.2	V	

●Electrical characteristics (unless otherwise noted, Ta = 25°C and Vcc = 12V)

Parameter	Symbol	Min.	Typ.	Max.	Unit	Conditions
Supply current	I _{CC}	—	1.9	4.0	mA	
Hall amplifier input hysteresis (+)	V _{hys} ⁺	3	—	15	mV	
Hall amplifier input hysteresis (—)	V _{hys} [—]	—3	—	—15	mV	
Pin 3 constant current	I ₃	5	6.8	10	mA	
Pin 6 constant current	I ₆	5	6.8	10	μA	
Pin 6 clamp voltage	V ₆	3.1	—	3.7	V	
Pin 7 Output high level voltage	V _{7H}	10	10.5	—	V	I _o =10mA
Pin 8 Output high level voltage	V _{8H}	10	10.5	—	V	I _o =10mA

●Rotational speed sensing and lock detection (6 pin)

The circuit around pin 6 is described in Fig. 1. Normally, the C₆ external capacitor is charging or discharging around the Hall signal when the motor is running. When the motor is locked, discharging does not occur at C₆ because the Hall signal stops switching. Charging continues at C₆ until the voltage increases to the pin-6 clamp voltage, and then Q₁ turns ON to turn OFF the output. With the pin-6 current being constant (I₆=6.8μA, typical), the time required after the motor is locked until the output current is turned OFF (duration between B and C in Fig. 2) is determined by the C₆ capacitance.

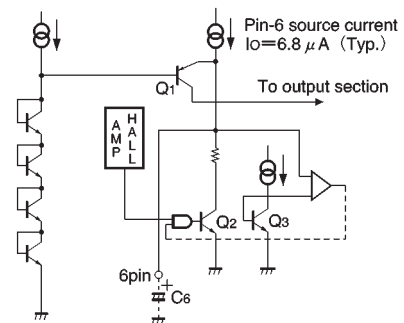

Fig.1

$$T_{off}=T_{B-C} = \frac{(V_{6CL} - V_{BEQ3}) C_6}{I_6}$$

$$\doteq \frac{4V_{BE} \cdot C_6}{6.8\mu A \text{ (Typ.)}}$$

$$\doteq 4.12 \times 10^5 \times C_6 \text{ (sec) (Typ.)}$$

where V_{6CL} is pin-6 clamp voltage (nearly equal to 5V_{BE})
 For C₆=2.2μF, for example, T_{off} is about 0.91s (typical).

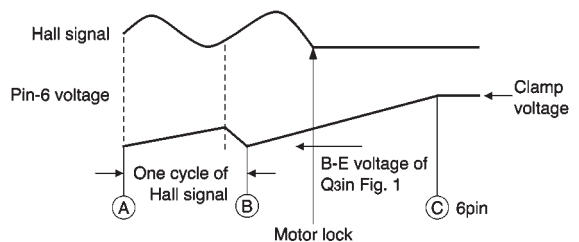

Fig.2

●Operation notes

- Hall constant current source (3 pin, 6.8mA typically), which is directly connected with the IC bias circuit, is not available when pin 3 is OPEN (saturated).
- Power dissipation
 The allowable power dissipation is plotted against ambient temperature in Fig. 3.

●Thermal derating curve

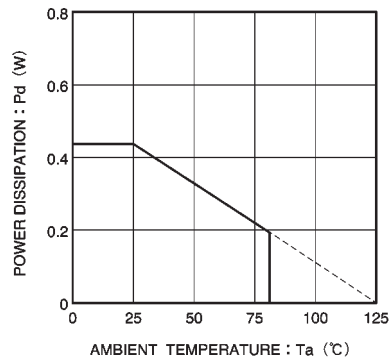

Fig.3

(3) Power dissipation

The power consumed in the IC can be calculated from the following equation :

$$P_C = \sum_{n=1}^3 P_{Cn}$$

1) P_{C1} is power consumed by the circuit current.

$$P_{C1} = V_{CC} \times I_{CC}$$

2) P_{C2} is power consumed by the Hall current (pin 3).

$$P_{C2} = I_3 \times V_3$$

where V_3 =pin 3 voltage. Connecting a resistor between the V_{CC} pin and pin 3 effectively reduces the IC current consumption.

3) P_{C3} is power consumed by the output current.

$$P_{C3} = (V_{CC} - V_{OH}) \times I_O$$

V_{OH} is the HIGH level voltage of pins 7 and 8. Power consumption can be reduced by raising the h_{FE} -rank of the external output transistor and thereby reducing the I_O value. Make sure that your application does not exceed the allowable power dissipation of the IC.

(4) Restarting when motor is locked

The outputs are turned OFF if the motor is stopped for some reason. To restart the motor from this situation, turn off the power first, fully discharge the pin 6 capacitor next, and then turn on the power again.

●Electrical characteristic curve

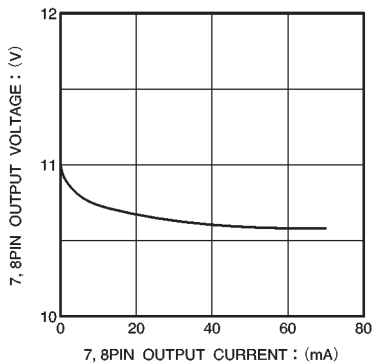

Fig.4 Output voltage vs. output current for pins 7 and 8

●External dimensions (Units: mm)

