

5-channel BTL driver for CD players

BA6796FP

The BA6796FP, an IC designed for CD and MD players, has a 5-channel BTL power driver and a standard operational amplifier. The spindle and tray driver share a single output buffer, and are specified with a control pin. In addition, the internal level shift circuit reduces the number of attached components.

●Applications

CD players, CD-ROM drives, MD players and other optical disc devices

●Features

- 1) 5-channel BTL driver in a 28-pin HSOP package, allowing for application miniaturization.
- 2) The five drivers are turned on and off according to control pin logic combinations.
- 3) The tray driver operates even when the servo power supply drops.
- 4) Internal thermal shutdown circuit.
- 5) Gain is adjustable with an attached resistor.
- 6) Internal standard operational amplifier.

●Absolute maximum ratings (Ta = 25°C)

| Parameter | Symbol | Limits | Unit |
|-----------------------|------------------|----------|------|
| Power supply voltage | V _{cc} | 18 | V |
| Power dissipation | P _d | 1.7* | W |
| Operating temperature | T _{opr} | -35~+85 | °C |
| Storage temperature | T _{stg} | -55~+150 | °C |

* When mounted on a 50 × 50 × 1 mm paper phenol board
Reduced by 13.6 mW for each increase in Ta of 1°C over 25°C.

●Recommended operating conditions (Ta = 25°C)

| Parameter | Symbol | Min. | Typ. | Max. | Unit |
|----------------------|-----------------|------|------|------|------|
| Power supply voltage | V _{cc} | 4.8 | — | 12 | V |



● Block diagram

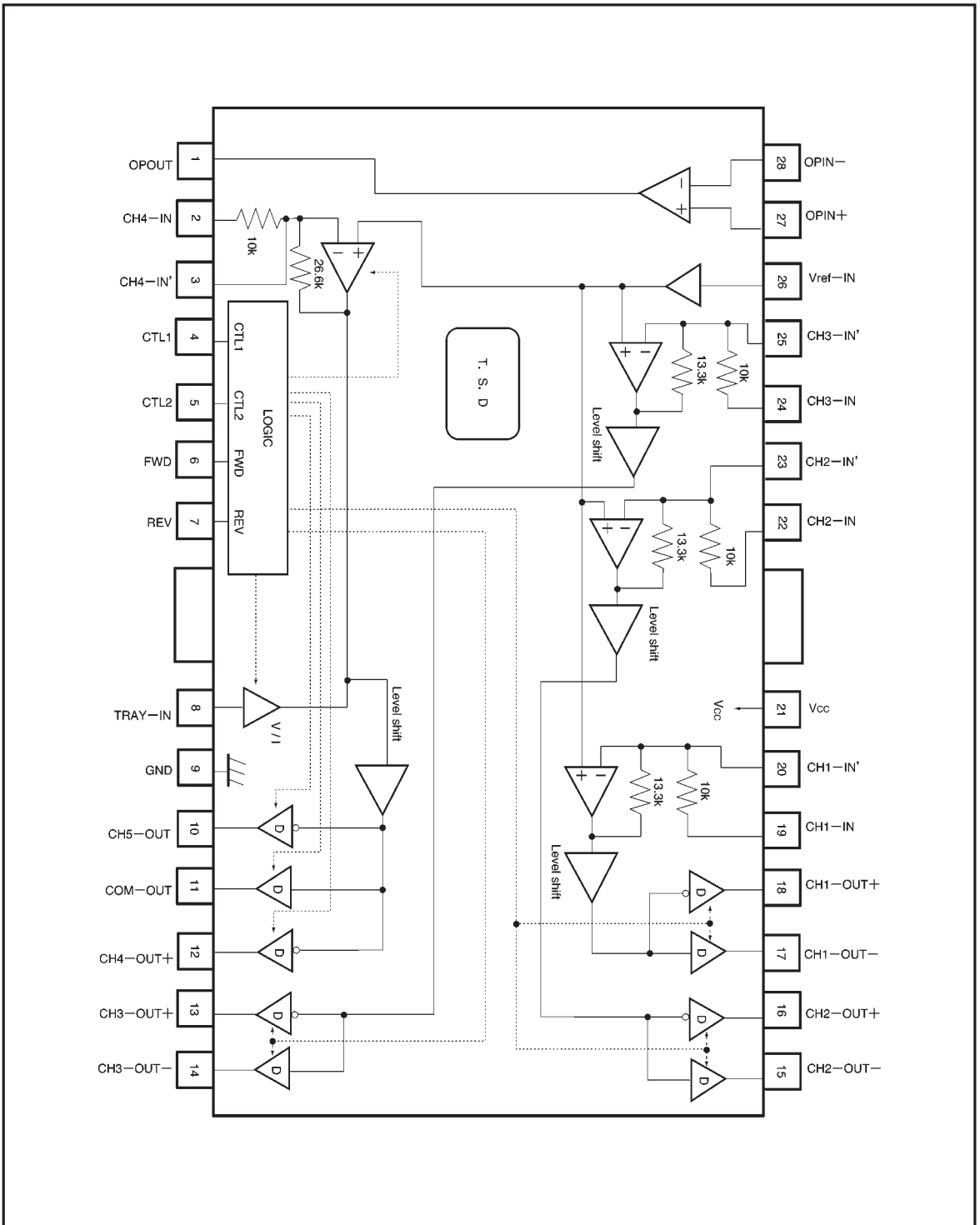

● Pin descriptions

| Pin No. | Pin name | Function |
|---------|-----------------|--|
| 1 | OPOUT | Operational amplifier |
| 2 | CH4—IN | Channel 4 input |
| 3 | CH4—IN' | Channel 4 gain adjustment input |
| 4 | CTL1 | Control 1 input |
| 5 | CTL2 | Control 2 input |
| 6 | FWD | Tray forward input |
| 7 | REV | Tray reverse input |
| 8 | TRAY—IN | Tray input |
| 9 | GND | Substrate ground |
| 10 | CH5—OUT— | Tray negative output |
| 11 | COM—OUT | Tray positive output/channel 4 negative output |
| 12 | CH4—OUT+ | Channel 4 positive output |
| 13 | CH3—OUT+ | Channel 3 positive output |
| 14 | CH3—OUT— | Channel 3 negative output |
| 15 | CH2—OUT— | Channel 2 negative output |
| 16 | CH2—OUT+ | Channel 2 positive output |
| 17 | CH1—OUT— | Channel 1 negative output |
| 18 | CH1—OUT+ | Channel 1 positive output |
| 19 | CH1—IN | Channel 1 input |
| 20 | CH1—IN' | Channel 1 gain adjustment input |
| 21 | V _{cc} | V _{cc} |
| 22 | CH2—IN | Channel 2 input |
| 23 | CH2—IN' | Channel 2 gain adjustment input |
| 24 | CH3—IN | Channel 3 input |
| 25 | CH3—IN' | Channel 3 gain adjustment input |
| 26 | VREF—IN | Bias amplifier input |
| 27 | OPIN+ | Operational amplifier non-inverted input |
| 28 | OPIN— | Operational amplifier inverted input |

* Positive and negative output of the driver is relative to the polarity of the input pins.
(For example, pin 18 outputs the high level when the high level is input to pin 19.)

● Input / output circuits

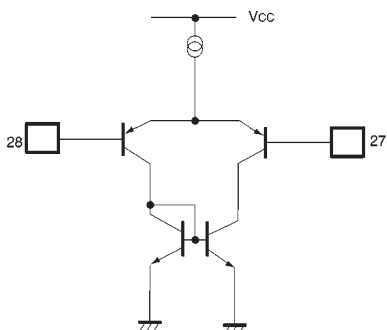
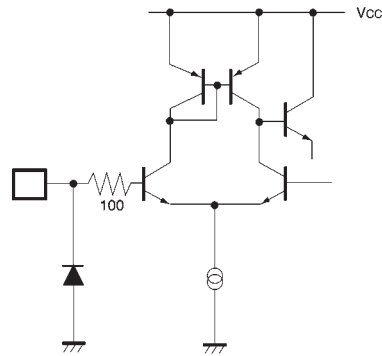
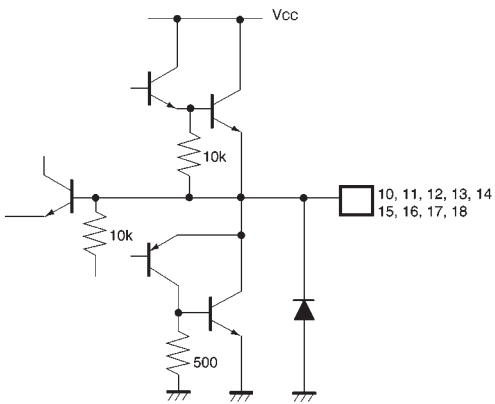
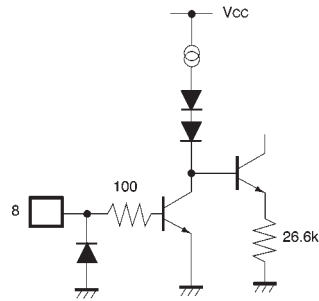
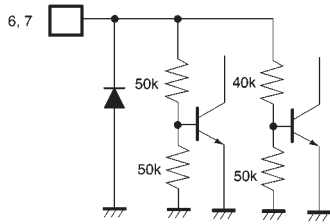
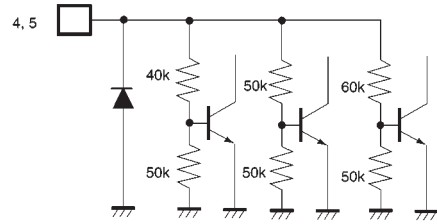
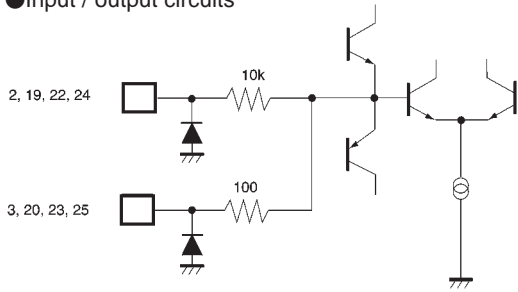

●Electrical characteristics (unless otherwise noted, Ta = 25°C, V_{CC} = 8V, f = 1kHz, R_L = 8Ω)

| Parameter | Symbol | Min. | Typ. | Max. | Unit | Conditions |
|-------------------------------|-------------------|------|------|------|------|---|
| Quiescent current dissipation | I _{CC} | 8.5 | 11.5 | 14.5 | mA | No load |
| Output offset voltage 1 | V _{OO} | -40 | - | 40 | mV | Channel 1~Channel 3 |
| Output offset voltage 2 | V _{OO} | -100 | - | 100 | mV | Channel 4 |
| Max. output pin voltage 1 | V _{OHD1} | 3.7 | 4.3 | - | V | V _{IN} =V _{CC} |
| Max. output pin voltage 2 | V _{OHD2} | - | -4.3 | -3.7 | V | V _{IN} =GND |
| Closed loop voltage gain 1 | G _{VC1} | 6.5 | 8.0 | 9.5 | dB | V _{IN} =0.1V _{rms} , 1kHz (excluding channel 4) |
| Closed loop voltage gain 2 | G _{VC2} | 11.5 | 14.0 | 16.5 | dB | V _{IN} =0.1V _{rms} , 1kHz (CH4) |
| Ripple rejection rate | RR | - | 60 | - | dB | V _{IN} =0.1V _{rms} , 100Hz |
| Slew rate | SR | - | 2.0 | - | V/μs | 100 Hz square wave, 3 V _{P-P} output |
| 〈Tray driver〉 | | | | | | |
| Output voltage F | V _{OF} | 2.5 | 3.0 | 3.5 | V | Pin 8 voltage=3 V |
| Output voltage R | V _{OR} | -3.5 | -3.0 | -2.5 | V | Pin 8 voltage=3 V |
| Output voltage range F | V _{OMF} | 3.7 | 4.3 | - | V | Pin 8 voltage=5 V |
| Output voltage range R | V _{OMR} | - | -4.3 | -3.7 | V | Pin 8 voltage=5 V |
| Load regulation F | ΔV _{FI} | - | 250 | 500 | mV | I _L =100~400 mA, pin 8 voltage=2.5 V |
| Load regulation R | ΔV _{RI} | - | 250 | 500 | mV | I _L =100~400 mA, pin 8 voltage=2.5 V |
| Line regulation F | ΔV _{FL} | - | 300 | 600 | mV | V _{CC} =5V~12V |
| Line regulation R | ΔV _{RL} | - | 300 | 600 | mV | V _{CC} =5V~12V |
| Output offset voltage | V _{OOL} | -50 | - | 50 | mV | Braked, output voltage |
| 〈Logic: CTL1, CTL2, FWD, REV〉 | | | | | | |
| Input high level voltage | V _{IH} | 2.0 | - | 8.0 | V | Maximum value up to V _{CC} |
| Input low level voltage | V _{IL} | -0.3 | - | 0.5 | V | |
| Input high level current | I _{IH} | - | - | 500 | μA | |
| Input low level current | I _{IL} | - | - | 500 | μA | |
| 〈Operational amplifier〉 | | | | | | |
| Offset voltage | V _{OFOP} | -5 | 0 | 5 | mV | |
| Input bias current | I _{BIAS} | - | - | 300 | nA | |
| Output high level voltage | V _{OHO} | 6.0 | - | - | V | |
| Output low level voltage | V _{OLO} | - | - | 1.8 | V | |
| Output drive current (source) | I _{OSO} | 10 | 40 | - | mA | 50 Ω at GND |
| Output drive current (sink) | I _{OSI} | 10 | 50 | - | mA | 50 Ω at V _{CC} |
| Open loop voltage gain | G _{VO} | - | 78 | - | dB | V _{IN} =-75dBV, 1kHz |
| Slew rate | SR _{OP} | - | 1 | - | V/μs | 100 Hz square wave, 4 V _{P-P} output |
| Ripple rejection | RR _{OP} | - | 65 | - | dB | V _{IN} =0.1V _{rms} , 100Hz |
| Common mode rejection ratio | CMRR | - | 84 | - | dB | V _{IN} =0.1V _{rms} , 1kHz |

● Measurement circuit

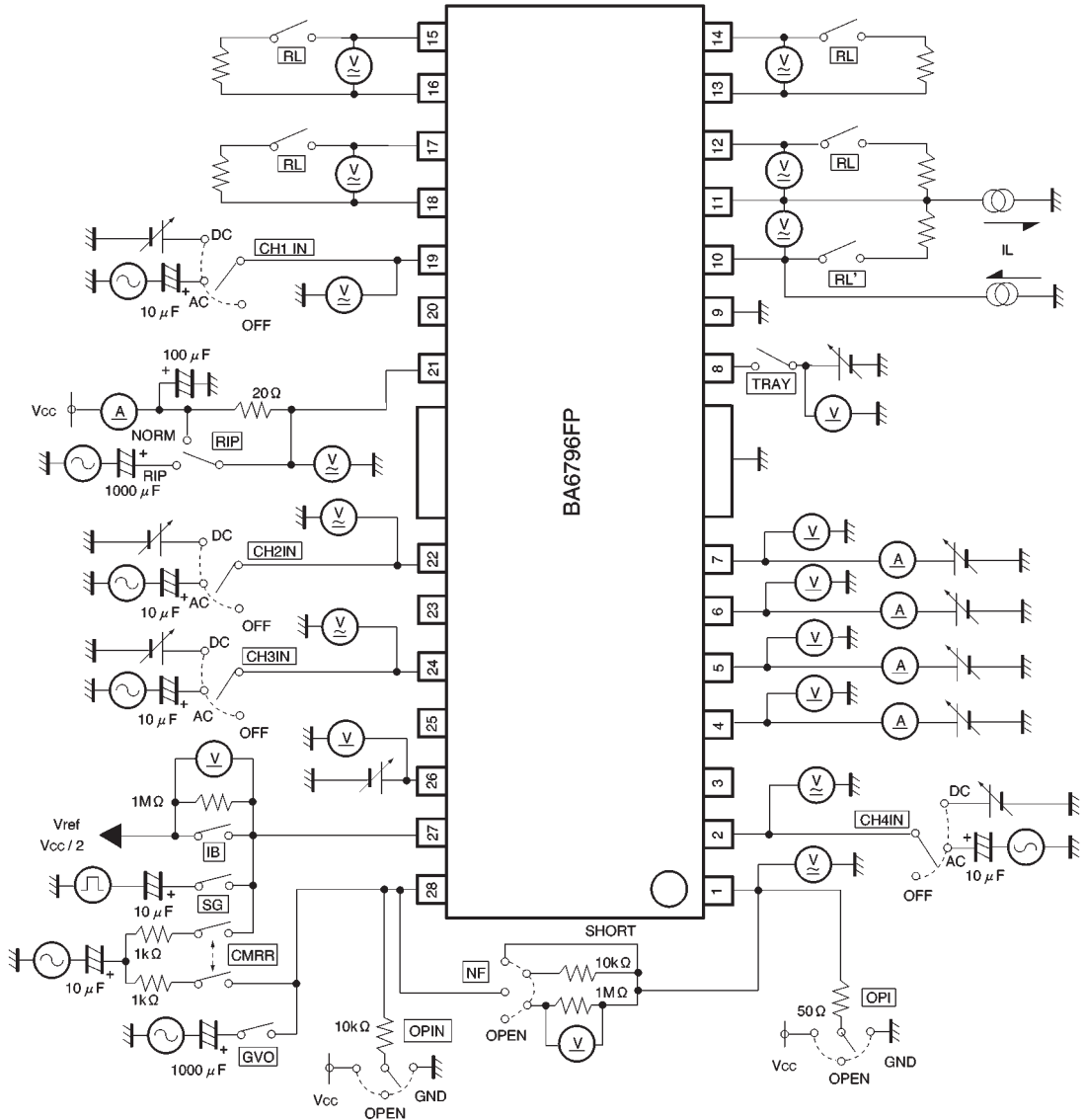

Fig.1

● Measurement circuit switch table

| Parameter | Symbol | RL | RL' | CH1IN | CH2IN | CH3IN | CH4IN | TRAY | NF | IB | OPIN | OPI | GVO | RIP |
|-------------------------------|-------------------|-----|-----|---------------------------------|-------|-------|-------|------|-------|-----|-----------------|-----------------|-----|------|
| Quiescent current dissipation | I _{CC} | OFF | | OFF | | | | OFF | SHORT | ON | OPEN | OPEN | OFF | NORM |
| Output offset voltage | V _{OO} | ON | | DC (BIAS) | | | | ↓ | ↓ | ↓ | ↓ | ↓ | ↓ | ↓ |
| Max. output pin voltage 1 | V _{OHD1} | ↓ | | DC (GND) | | | | ↓ | ↓ | ↓ | ↓ | ↓ | ↓ | ↓ |
| Max. output pin voltage 2 | V _{OHD2} | ↓ | | DC (V _{CC}) | | | | ↓ | ↓ | ↓ | ↓ | ↓ | ↓ | ↓ |
| Closed loop voltage gain 1 | G _{VC1} | ↓ | | AC (0.1V _{rms} , 1kHz) | | | | ↓ | ↓ | ↓ | ↓ | ↓ | ↓ | ↓ |
| Closed loop voltage gain 2 | G _{VC2} | ↓ | | ↓ | | | | ↓ | ↓ | ↓ | ↓ | ↓ | ↓ | ↓ |
| Ripple rejection rate | RR | ↓ | | DC (BIAS) | | | | ↓ | ↓ | ↓ | ↓ | ↓ | ↓ | RIP |
| Slew rate | SR | ↓ | | AC (100 Hz square wave) | | | | ↓ | ↓ | ↓ | ↓ | ↓ | ↓ | NORM |
| 〈Tray driver〉 | | | | | | | | | | | | | | |
| Output voltage F | V _{OF} | ON | | DC (BIAS) | | | | ON | SHORT | ON | OPEN | OPEN | OFF | NORM |
| Output voltage R | V _{OR} | ↓ | | ↓ | | | | ↓ | ↓ | ↓ | ↓ | ↓ | ↓ | ↓ |
| Output voltage range F | V _{OMF} | ↓ | | ↓ | | | | ↓ | ↓ | ↓ | ↓ | ↓ | ↓ | ↓ |
| Output voltage range R | V _{OMR} | ↓ | | ↓ | | | | ↓ | ↓ | ↓ | ↓ | ↓ | ↓ | ↓ |
| Load regulation F | ΔV _{FI} | ON | OFF | ↓ | | | | ↓ | ↓ | ↓ | ↓ | ↓ | ↓ | ↓ |
| Load regulation R | ΔV _{RI} | ↓ | ↓ | ↓ | | | | ↓ | ↓ | ↓ | ↓ | ↓ | ↓ | ↓ |
| Line regulation F | ΔV _{FL} | ON | | ↓ | | | | ↓ | ↓ | ↓ | ↓ | ↓ | ↓ | ↓ |
| Line regulation R | ΔV _{RL} | ↓ | | ↓ | | | | ↓ | ↓ | ↓ | ↓ | ↓ | ↓ | ↓ |
| Output offset voltage | V _{OO} | ↓ | | ↓ | | | | ↓ | ↓ | ↓ | ↓ | ↓ | ↓ | ↓ |
| 〈Logic: CTL1, CTL2, FWD, REV〉 | | | | | | | | | | | | | | |
| Input high level voltage | V _{IH} | OFF | | OFF | | | | OFF | SHORT | ON | OPEN | OPEN | OFF | NORM |
| Input low level voltage | V _{IL} | ↓ | | ↓ | | | | ↓ | ↓ | ↓ | ↓ | ↓ | ↓ | ↓ |
| Input high level current | I _{IH} | ↓ | | ↓ | | | | ↓ | ↓ | ↓ | ↓ | ↓ | ↓ | ↓ |
| Input low level current | I _{IL} | ↓ | | ↓ | | | | ↓ | ↓ | ↓ | ↓ | ↓ | ↓ | ↓ |
| 〈Operational amplifier〉 | | | | | | | | | | | | | | |
| Offset voltage | V _{OPOP} | OFF | | OFF | | | | OFF | SHORT | ON | OPEN | OPEN | OFF | NORM |
| Input bias current | I _{BIAS} | ↓ | | ↓ | | | | ↓ | 1M | OFF | ↓ | ↓ | ↓ | ↓ |
| Output high level voltage | V _{OHO} | ↓ | | ↓ | | | | ↓ | 10k | ON | GND | ↓ | ↓ | ↓ |
| Output low level voltage | V _{OLO} | ↓ | | ↓ | | | | ↓ | ↓ | ↓ | V _{CC} | ↓ | ↓ | ↓ |
| Output drive current (source) | I _{OSO} | ↓ | | ↓ | | | | ↓ | SHORT | ↓ | OPEN | GND | ↓ | ↓ |
| Output drive current (sink) | I _O | ↓ | | ↓ | | | | ↓ | ↓ | ↓ | ↓ | V _{CC} | ↓ | ↓ |
| Open loop voltage gain | G _{VO} | ↓ | | ↓ | | | | ↓ | 10k | ↓ | ↓ | OPEN | ON | ↓ |
| Slew rate | S _{ROP} | ↓ | | ↓ | | | | ↓ | SHORT | OFF | ↓ | ↓ | OFF | ↓ |
| Ripple rejection | R _{ROP} | ↓ | | ↓ | | | | ↓ | ↓ | ON | ↓ | ↓ | ↓ | RIP |
| Common mode rejection ratio | C _{MRR} | ↓ | | ↓ | | | | ↓ | 1M | OFF | ↓ | ↓ | ↓ | NORM |

*1 Switch SG is on only when measuring the operational amplifier's S_{ROP}.

*2 Switch CMRR is on only when measuring the operational amplifier's CMRR.

●Function description

CTL and CTL2

| CTL1 | CTL2 | CH1 | CH2 | CH3 | CH4 | CH5 |
|------|------|-----|-----|-----|-----|-----|
| L | L | OFF | | | | ON |
| L | H | OFF | | | | ON |
| H | L | ON | | | | OFF |
| H | H | OFF | ON | OFF | OFF | ON |

⊗ High-impedance output when off.

F and R (channel 5 control enabled only when channel 5 is on)

| F | R | Output mode |
|---|---|----------------|
| L | L | High impedance |
| L | H | Reverse |
| H | L | Forward |
| H | H | Brake |

● Application example

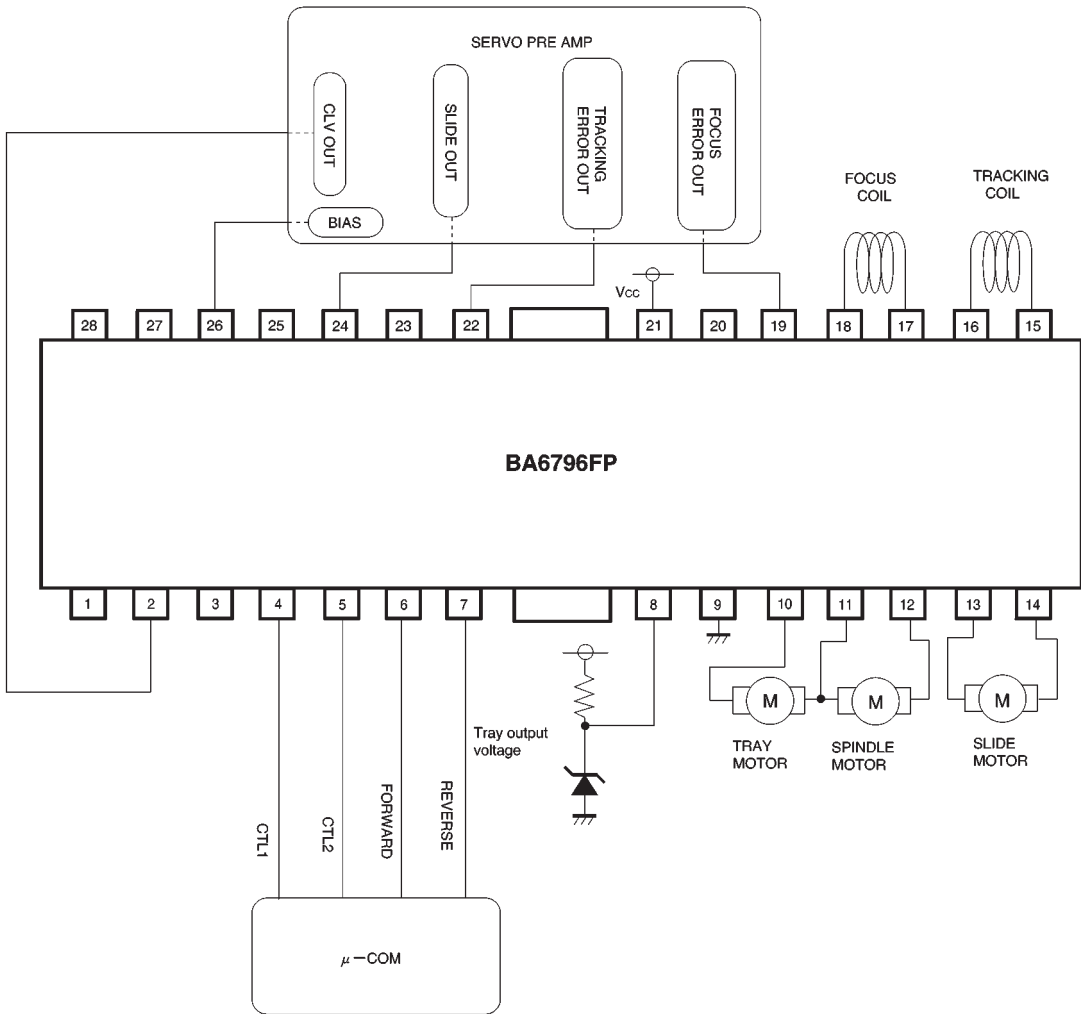

Fig. 2

● Operation notes

(1) Setting the tray motor driver voltage (forward mode)

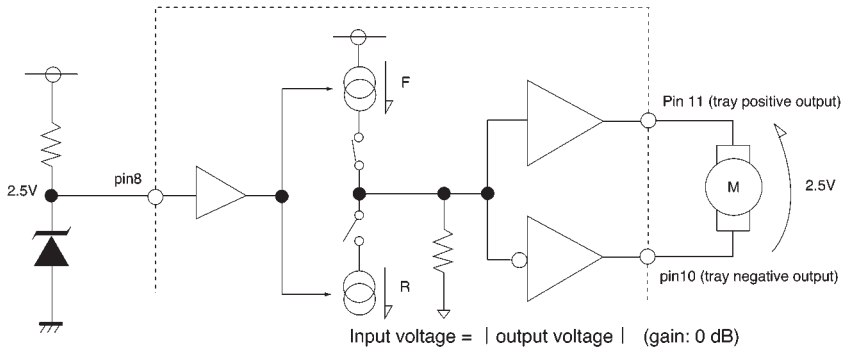

Fig. 3

Note: The tray driver output voltage will not exceed the power supply's maximum output voltage, even if set above this maximum voltage (refer to the following page). The example above applies only when setting below the maximum output voltage. Maximum output voltage for the power supply can be output by pulling up the tray input pin (pin 8), or by connecting it to Vcc.

(2) Mute functions

| Mute function | Muted channels |
|-----------------------------------|----------------|
| Thermal shutdown | All channels |
| Muting during supply voltage drop | All channels |
| Muting during bias voltage drop | CH1-CH4 |

«Thermal shutdown»

The output current is muted when the chip temperature exceeds 175°C (typically).

«Supply voltage drop muting»

The internal circuits turn off when the supply voltage drops below 4.3V (typically), and turn on again when it rises above 4.5V (typically).

● Electrical characteristic curves

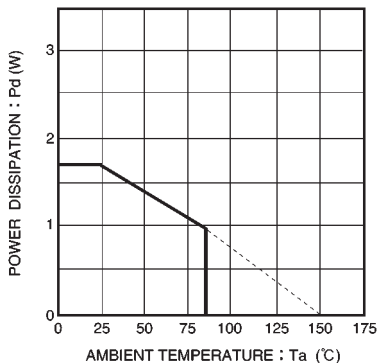

Fig. 4 Thermal derating curve

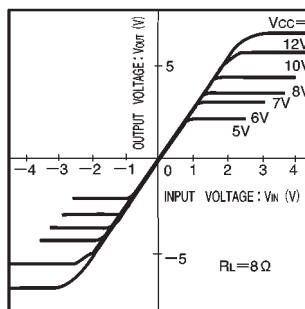

Fig. 5 CH1-CH3 Driver I/O characteristics (when variable supply voltage changes)

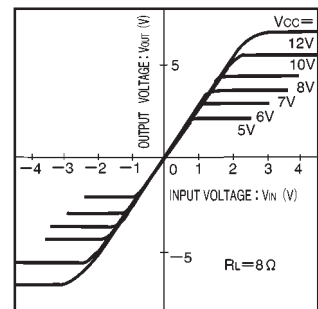

Fig. 6 CH4 Driver I/O characteristics (when variable supply voltage changes)

«Bias drop muting»

Muting also occurs when the bias pin voltage (26 pin) is lowered below 1.4V (typically). Be sure the voltage stays between 1.6V and 6.5V during normal operation.

(3) Muting occurs during thermal shutdown and when the supply voltage or bias pin voltage drops. In each case, only the driver is muted. The output pin voltage during muting is the internal bias voltage, roughly $V_{CC} - V_F / 2$.

(4) Attach a 0.1μF bypass capacitor to the power supply, at the base of the IC.

(5) Connect the radiating fin to an external ground.

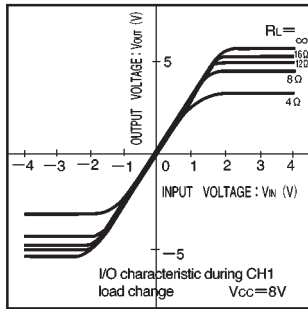

Fig. 7 CH1-CH3 Driver I / O characteristics (when load changes)

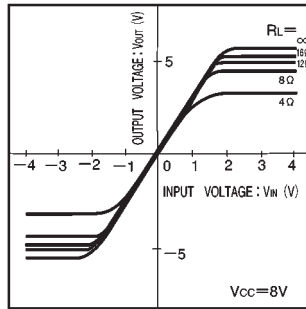

Fig. 8 CH4 Driver I / O characteristics (when load changes)

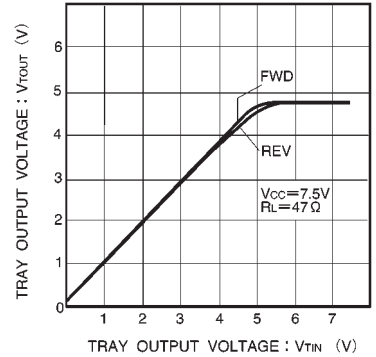

Fig. 9 Tray driver output characteristics

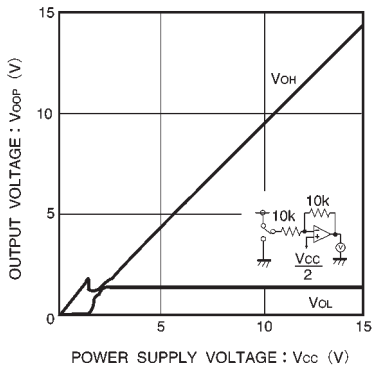

Fig. 10 Power supply voltage vs. HIGH output / LOW output voltage

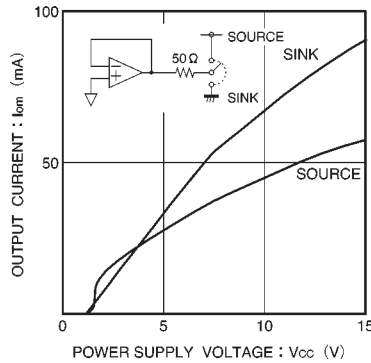

Fig. 11 Power supply voltage vs. operational amplifier output operating current

● External dimensions (Units: mm)

