

LED level meter driver, 12-point × 2 channel, VU scale, bar display

BA6820F / BA6822S / BA6822F

The BA6820F, BA6822S and BA6822F are two-channel, 12-point LED drivers for VU-scale bar-level meters.

The ICs are available in 22-pin SOP (BA6820F and BA6822F) and 22-pin shrink-DIP (BA6822S) packages, and use a dynamic-drive system that can drive two 12-point displays. The ICs have independent AC and DC inputs, and the AC input mode has a peak hold circuit (with cancel function). The ICs also feature a power-on mute, so steps to prevent erroneous LED lighting at power on are not required.

The input resistance of the AC inputs is 3k Ω (Typ.) for the BA6820F and 0.3k Ω (Typ.) for the BA6822S/F.

●Applications

Level meters for VCRs, stereo cassette players, audio amplifiers and karaoke equipment.

●Features

- 1) Uses dynamic-drive system to display two 12-point channels. 22-pin SOP and 22-pin shrink DIP packages.
- 2) Independent AC and DC inputs provided (one input displays one channel). Switching function allows two-mode display.
- 3) Upper 8 points have peak hold function in AC mode (two seconds). A peak-hold cancel function is also provided.
- 4) A mute function is provided, and muting can be applied externally.
- 5) Power on mute function.



●Block diagram

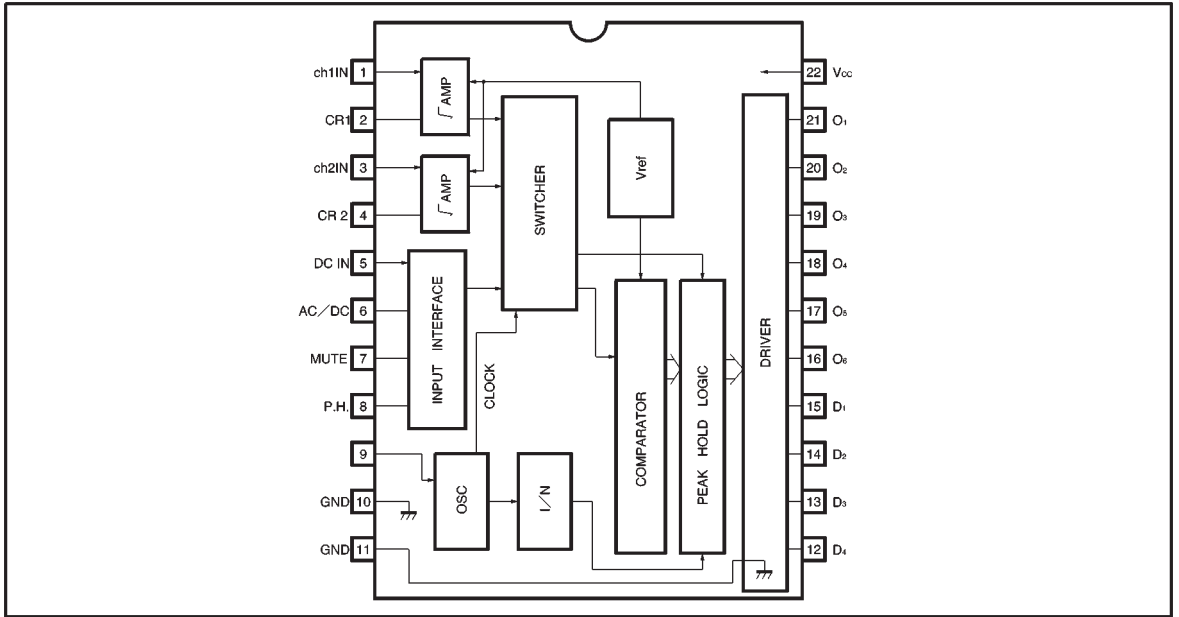

●Absolute maximum ratings

(BA6820F/BA6822F) (Ta = 25°C)

Parameter	Symbol	Limits	Unit
Power supply voltage	V _{CC}	7.0	V
Power dissipation	P _d	450*	mW
Operating temperature	T _{opr}	-20~+70	°C
Storage temperature	T _{stg}	-55~+125	°C
Maximum output driver current	I _{OM}	40	mA
Maximum display switch driver current	I _{DM}	20	mA

* Reduced by 4.5mW for each increase in Ta of 1°C over 25°C.

(BA6822S) (Ta = 25°C)

Parameter	Symbol	Limits	Unit
Power supply voltage	V _{CC}	7.0	V
Power dissipation	P _d	1000*	mW
Operating temperature	T _{opr}	-20~+70	°C
Storage temperature	T _{stg}	-55~+125	°C
Maximum output driver current	I _{OM}	60	mA
Maximum display switch driver current	I _{DM}	30	mA

* Reduced by 10mW for each increase in Ta of 1°C over 25°C.

●Recommended operating conditions (Ta = 25°C)

Parameter	Symbol	Min.	Typ.	Max.	Unit	Conditions
Oscillator frequency	f _{osc}	—	4	—	kHz	C=0.01 μF R=41kΩ

Audio ICs

BA6820F / BA6822S / BA6822F

● Electrical characteristics (unless otherwise noted, Ta = 25°C, V_{CC} = 5.0V and f = 1kHz)

Parameter	Symbol	Min.	Typ.	Max.	Unit	Conditions	
Operating power supply voltage	V _{CC}	4.5	5.0	5.5	V	—	
Quiescent current	I _Q	—	10	15	mA	Not input, when output off	
〈1 / 2 divider amplifier 1〉							
Quiescent input voltage	V _{OO}	—	30	100	mV	I _{IN} =0, R _L =47kΩ	
Input resistance	BA6820F	R _{IN}	2	3	4	kΩ	—
	BA6822S/F		0.2	0.3	0.4		
Output voltage	BA6820F	V _{OUT}	600	1000	1400	mV	I _{IN} =-100 μA R _L =47kΩ
	BA6822S/F		500	890	1400		
Maximum input current	I _{IM}	1.2	2	—	mA	—	
Crosstalk	CT	—	40	120	mV	V _{IN} =1.8Vrms	
Differential output voltage	ΔV _{OUT}	-250	0	250	mV	I _{IN} =-100 μA, R _L =47kΩ	
Output voltage linearity	BA6820F	ΔV/ΔI	400	650	900	mV	I _{IN} =-10~-100 μA
	BA6822S/F		350	650	900		
〈DC input〉							
DC input resistance	R _{INDC}	30	50	70	kΩ	—	
〈Oscillator〉							
Oscillator frequency	f _{OSC}	3.5	4.0	4.5	kHz	C=0.01 μF, R=41kΩ	
〈Display output〉							
Peak hold time *1	T _{hold}	—	2	—	s	f _{osc} =4kHz	
Display switch output duty cycle	duty	—	7/32	—	—	—	
Display switch output low level voltage	V _{DL}	—	0.1	0.3	V	I _L =10mA, pins12 to15	
Display switch output leakage current	I _{Dleak}	—	—	10	μA	V _{CE} =5V, pins12 to15	
LED driver output low level voltage	V _{OL}	—	0.3	0.7	V	I _O =30mA, pins16 to21	
LED driver output leakage current	I _{Dleak}	—	—	10	μA	V _{CE} =5V, pins16 to21	
Mute time at power on	T _{mute}	—	1	—	s	f _{osc} =4kHz	
AC/DC switching threshold level	V _{TH6}	2.2	2.5	2.8	V	"H" ; AC, "L" ; DC6pin	
Forced mute input threshold	V _{TH7}	2.2	2.5	2.8	V	"H": mute (pin 7)	
Peak hold cancel input threshold	V _{TH8}	2.2	2.5	2.8	V	"H": cancel (pin 8)	
〈Comparator〉							
AC comparator level 12	V _{C12AC}	8.5	10	12	dB	Output: pin 16*3	
AC comparator level 11	V _{C11AC}	5.5	7	8.5	dB	Output: pin 16*3	
AC comparator level 10	V _{C10AC}	3.0	4	5.5	dB	Output: pin 17*3	
AC comparator level 9	V _{C9AC}	1.0	2	3.0	dB	Output: pin 17*3	
AC comparator level 8	V _{C8AC}	—	0	—	dB	Output: pin 18*3	
AC comparator level 7	V _{C7AC}	-3.0	-2	-1.0	dB	Output: pin 18*3	
AC comparator level 6	V _{C6AC}	-5.5	-4	-3.0	dB	Output: pin 19*3	
AC comparator level 5	V _{C5AC}	-8.5	-7	-5.5	dB	Output: pin 19*3	
AC comparator level 4	V _{C4AC}	-15	-10	-8.5	dB	Output: pin 20*3	
AC comparator level 3	V _{C3AC}	-25	-20	-15	dB	Output: pin 20*3	
AC comparator level 2	V _{C2AC}	-33	-30	-25	dB	Output: pin 21*3	
AC comparator level 1	V _{C1AC}	-55	-38	-33	dB	Output: pin 21*3	

Parameter	Symbol	Min.	Typ.	Max.	Unit	Conditions
AC sensitivity	BA6820F	170	308	450	mV _{rms}	AC comparator level 8 on level
	BA6822S/F	220	400	580		
DC comparator level 12	V _{C12DC}	2.78	3.10	3.44	V	Output: pin 16*4
DC comparator level 11	V _{C11DC}	2.35	2.64	2.90	V	Output: pin 16*4
DC comparator level 10	V _{C10DC}	1.98	2.23	2.48	V	Output: pin 17*4
DC comparator level 9	V _{C9DC}	1.75	2.00	2.25	V	Output: pin 17*4
DC comparator level 8	V _{C8DC}	1.50	1.76	2.00	V	Output: pin 18*4
DC comparator level 7	V _{C7DC}	1.35	1.58	1.85	V	Output: pin 18*4
DC comparator level 6	V _{C6DC}	1.20	1.42	1.65	V	Output: pin 19*4
DC comparator level 5	V _{C5DC}	1.00	1.18	1.35	V	Output: pin 19*4
DC comparator level 4	V _{C4DC}	0.80	1.00	1.15	V	Output: pin 20*4
DC comparator level 3	V _{C3DC}	0.35	0.51	0.70	V	Output: pin 20*4
DC comparator level 2	V _{C2DC}	0.15	0.25	0.35	V	Output: pin 21*4
DC comparator level 1	V _{C1DC}	0.05	0.11	0.20	V	Output: pin 21*4

- * 1 Peak hold for comparator levels for 5 to 12. There is no peak hold for DC input.
- * 2 Display switch output duty cycle.

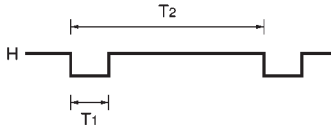

Display switch output duty cycle = T_1/T_2

- * 3 The reference value for the AC comparator is the level of comparator 8.
- * 4 Only ch2 is effective in DC input mode.

● Measurement circuit

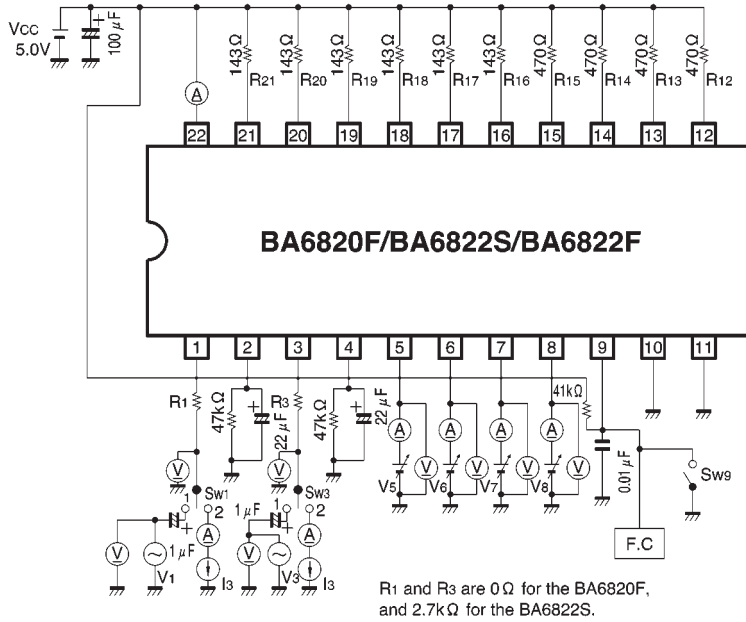

Fig. 1

● Application example

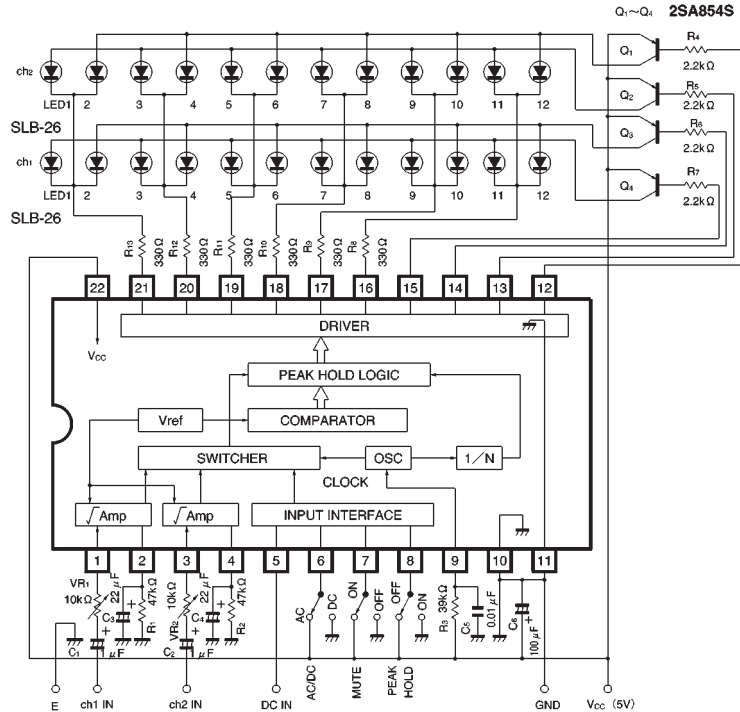

Fig. 2

● Attached components

• C₁ and C₂: 1μF input coupling capacitors (electrolytic) for the square-root compression amplifier. The rectified voltage output from pins 2 and 4 is attenuated by 1.5dB at the frequency determined by the following formula (refer to the data for the relationship between the pin 2 and 4 DC voltage frequency characteristics and the LED lighting level).

$$f_C = \frac{1}{2\pi \cdot C_1 (R_{IN} + VR_1)} \quad (R_{IN} = \text{input resistance})$$

When the LEDs light due to low-frequency mechanical noise or induced hum, reduce the values of C₁ and C₂ to cut the low-frequency frequency characteristic.

• VR₁ and VR₂: 5kΩ to 100kΩ potentiometers for sensitivity and L/R balance adjustment (refer to item 2 of Circuit operation).

• C₃ and C₄: 22μF electrolytic capacitors.

• R₁ and R₂: 47kΩ carbon-film resistors.

These resistors set the attack and release times (refer to item 6 of the Circuit operation).

• C₅: 0.01μF mylar capacitor.

R₃: 39kΩ carbon-film resistor.

This resistor sets the oscillator frequency (refer to the Operation notes).

• C₆: 100μF electrolytic capacitor. This capacitor is used as a ripple filter. The positive lead should be connected close to V_{CC} (pin 22), and the negative lead close to the junction of pins 10 and 11.

● Circuit operation

(1) Function

There are 12 LEDs each for the left and right channels, and these are divided into 4 groups of six. A dynamic-drive technique is used to drive the LEDs in order, and provide 12 display points for each channel. A 12-point VU-scale bar display is produced over the display range –38dB to +10dB. The top eight points have a peak hold function which may be cancelled if required (there is no peak hold function for DC mode).

Independent AC (two channels) and DC (one channel) inputs are provided, and a control input pin is used to switch between them.

In DC mode, only channel 2 operates.

A power-on mute circuit is provided, so no measures are required to prevent erroneous lighting of the LEDs when power is applied.

• Q₁ to Q₄: 2SA854S Transistors for display switching. If the current for one LED is I_{LED}, the values of I_C and P_C for each of Q₁ to Q₄ when all LEDs are lit are given by:

$$I_C = 6 \times I_{LED} \quad (\text{for duty cycle of } 7/32)$$

$$P_C = 6 \times I_{LED} \times V_{sat} \times \frac{7}{32}$$

Choose transistors that have sufficient margin for I_C and P_C.

• R₄ to R₇: 2.2kΩ carbon-film resistors.

These resistors limit the base current for transistors Q₁ to Q₂. The base current is the collector current divided by h_{FE}, but as the transistors are operated in the saturation region, h_{FE} will drop considerably. Choose the resistors so that sufficient base current flows.

• LED₁ to LED₁₂: SLB-26

• R₈ to R₁₃: 330Ω carbon-film resistors. These resistors set the LED current. Four LEDs are connected to each resistor, but as the LEDs light sequentially, only the current for one LED flows in a resistor.

$$R_{8 \sim 13} = \frac{V_{CC} - V_{LED} - V_{sat} (Q_1 - Q_4) - V_{DL}}{I_{LED}}$$

V_{DL} = Display switch output "L" voltage.

The attack and release times for the display can be set using external components.

(2) Input block (pins 1, 3 and 5)

Pins 1 and 3 are the AC inputs, and pin 5 is the DC input. Pin 6 is used to switch between AC and DC input. When the pin 6 input is "H", AC input is selected (pins 1 and 3), and when it is "L", DC input (pin 5) is selected. Therefore, if pins 1 and 3 are used for audio input, and pin 5 as the input for signal meter output (DC) from a tuner, the switch input (pin 6) can be used to make LED display do two jobs.

Pins 1 and 3 have low input impedance, so we recommend that you connect potentiometers (VR₁ and VR₂: 5kΩ to 100kΩ) in series with the inputs to adjust the balance between ch1 and ch2 and set the levels.

(3) Peak hold

The peak hold circuit momentarily holds the maximum signal level in AC input mode. The peak hold function applies to comparator levels 5 to 12 (8 points). When the oscillator frequency is 4kHz, the peak hold time is two seconds (Typ.), and can be changed by changing the oscillator frequency. The peak hold function can be turned off by setting pin 8 high.

The peak hold function does not operate in DC input mode.

(4) Output block

The two sets of 12 LEDs for the BA6820F and BA6822S/F are divided into 4 groups of six. A dynamic-drive technique is used to drive the LEDs in order, and display the input level.

Group 1

Channel 1 LEDs 1, 3, 5, 7, 9 and 11
(odd-numbered LEDs)

Group 2

Channel 1 LEDs 2, 4, 6, 8, 10 and 12
(even-numbered LEDs)

Group 3

Channel 2 LEDs 1, 3, 5, 7, 9 and 11
(odd-numbered LEDs)

Group 4

Channel 2 LEDs 2, 4, 6, 8, 10 and 12
(even-numbered LEDs)

Therefore, six LED drive outputs, and four display switch terminals are provided.

The output timing chart for when all LEDs are lit is shown in Fig. 3.

In DC input mode, only channel 2 operates.

D₁ to D₄ in the timing chart operate in the same way as for AC mode (i.e. D₁ and D₂ operate), but O₁ to O₆ are high for the channel 1 period.

1) Display switch outputs (pins 12 to 15)

To successively switch between the four LED groups, these outputs are active low (see Fig. 4).

The outputs are pulled up by 36kΩ resistors (between the base and emitter of Q₁ to Q₄), so leak current bypass resistors are not required.

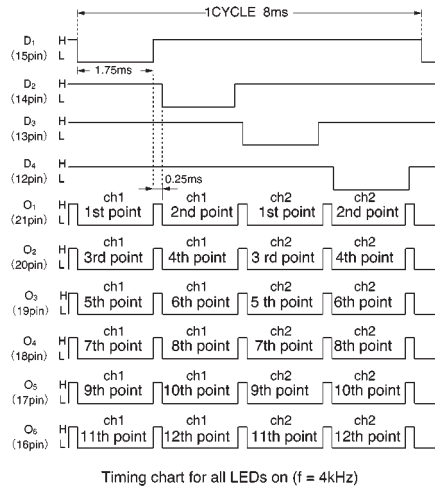

Fig. 3

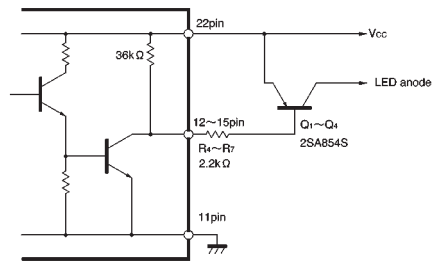

Fig. 4

2) LED drive outputs (pins 16 to 21)

These are open-collector outputs that drive the LEDs (see Fig. 5).

One complete cycle of the timing chart starting from O₁ (pin 21) is as follows: if the channel 1 input is higher than comparator level 1 during the first-point period for channel 1, a “L” level is output. Next, if the channel 1 input is higher than comparator level 2 during the second-point period for channel 1, a “L” level is output, if the channel 2 input is higher than comparator level 1 during the first-point period for channel 2, a “L” level is output, and then if the channel 2 input is higher than comparator level 2 during the second-point period for channel 2, a “L” level is output. This cycle is then repeated for outputs O₂ to O₆.

(5) Mode switch pins (pins 6, 7 and 8)

- AC/DC mode switch pin (pin 6)

When “H” AC input (pins 1 and 3) is selected, and when “L” DC input (pin 5) is selected.

“H”: 1, 3pin “L”: 5pin

- Mute (pin 7)

When “H”, mute is applied, and no display is output. Normally “L”.

- Peak hold (pin 8)

When “H”, peak hold for AC input is cancelled.

The circuit for these three mode switches is given in Fig. 6.

Pins 6 to 8 are pulled down by a 50kΩ resistor, so there is no need for the inputs to be connected to GND for a “L” input.

(6) Attack and release times (pins 2 and 4)

The output response to AC input signals is set by the RC circuits connected to pins 2 and 4 (R₁ and C₃ for channel 1, and R₂ and C₄ for channel 2).

R	C	Attack time	Release time
47kΩ	22 μF	14ms	2.7s
10kΩ	10 μF	5ms	0.3s

(Typ.)

Attack time: the time for pins 2 and 4 to go from 0V to 2V (when all 12 LEDs are lit) when the input signal goes from no signal to a 1.8V input signal with f = 1kHz (the input level at which the 12th LED lights is +6dB).

Release time: the time for pins 2 and 4 to go from 2V to 120mV (the level at which the first LED lights) when the input signal goes from a 1.8V input signal to no signal (the input level at which the 12th LED lights is +6dB).

The recommended values are 10kΩ to 47kΩ for R₁ and R₂ and 10μF to 22μF for C₃ and C₄. In DC mode, the attack and release times are zero seconds regardless of the RC circuits (see Fig. 7).

(7) Oscillator frequency (pin 9)

R₃ and C₅ connected to pin 9 determine the oscillator frequency.

The relationship between the oscillator frequency and the display switching period is as follows:

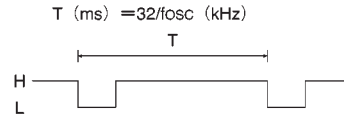

The LED drive output, display switch output period, peak hold time, and mute time when power is applied are all determined by the oscillation frequency, and are varied when the frequency is changed.

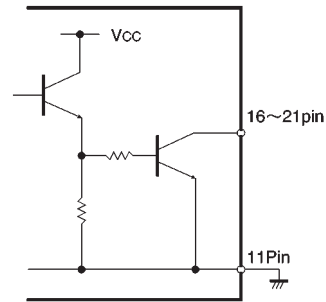

Fig. 5

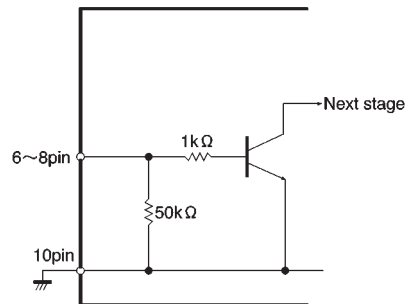

Fig. 6

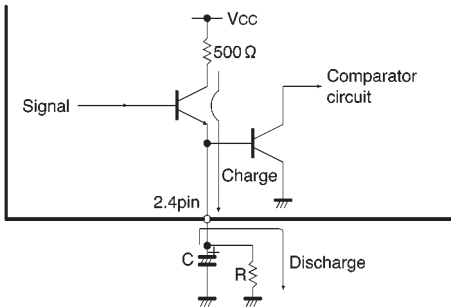

Fig. 7

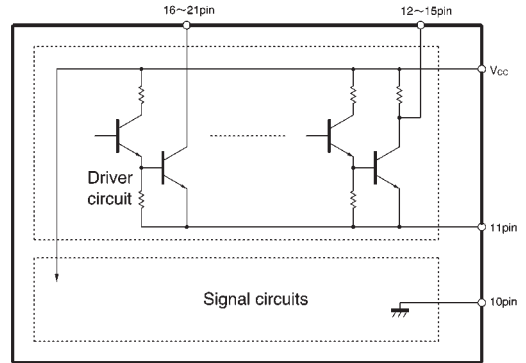

Fig. 8

(8) GND terminal (pins 10 and 11)

Pin 11 is the GND for the pin 12 to pin 21 driver circuits, and pin 10 is the GND for the other signal circuits (see Fig. 8).

Pins 10 and 11 are not connected internally, so both must be connected to GND.

The large LED current that flows from pin 11 has a large high-frequency component, so care must be taken with regard to the PCB layout to avoid faulty operation of the IC, and incorrect lighting of the LEDs due to noise.

● Operation notes

(1) Use the potentiometers VR1 and VR2 connected to pins 1 and 3 to set the 0dB levels and adjust the channel 1 and channel 2 balance.

(2) The recommended oscillator frequency is 4kHz (pin 9). The external component values for C_5 and R_3 are $0.01\mu\text{F}$ and $41\text{k}\Omega$ (or $39\text{k}\Omega$). If you wish to use other values, they should be in the ranges $0.001\mu\text{F}$ to $0.1\mu\text{F}$ and $10\text{k}\Omega$ to $100\text{k}\Omega$. (see Fig. 9).

(3) The dynamic ranges for the BA6820F and BA6822S/F comparators are large, and the comparators will operate even with low-level signals.

For this reason, noise may cause the LEDs to light when they should not, and to prevent this, GND line noise should be kept sufficiently low.

(4) Take care to ensure the none of the pins have a voltage applied to them that is higher than V_{CC} or lower than GND (e.g. supply the LED current from a source other than V_{CC}).

(5) In general, the level meter output block is switched on and off in the range GND to V_{CC} , and a large voltage with a large high-frequency component is generated.

Therefore, if the input and output lines are close, the out-

put may be fed back to the input and cause oscillation, incorrect LED lighting, or faulty operation of the IC. Design the PCB artwork so that there is no coupling between the input and output lines or with other units, in the same way as for linear amplifier PCB design. If they must be physically close, insert a capacitor between the input and GND to reduce the AC input impedance, and prevent noise from entering the input.

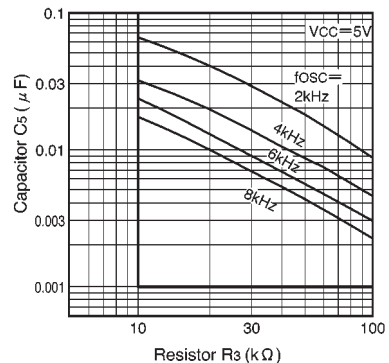

Range of the CR circuit connected to pin 9

Fig. 9

● Electrical characteristic curves

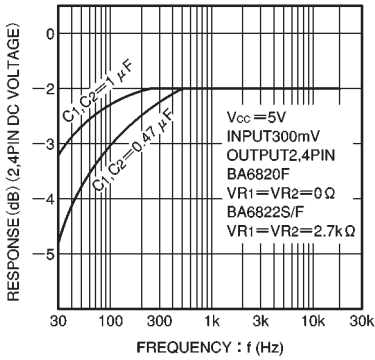

Fig. 10 Frequency characteristics

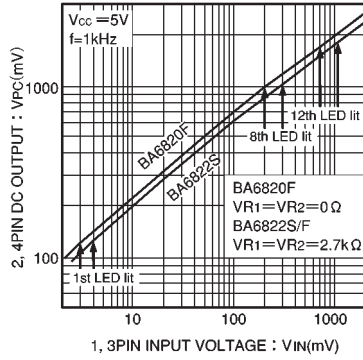

Fig. 11 Pin 2 and pin 4 DC output voltage vs. pin 1 and pin 3 AC input voltage

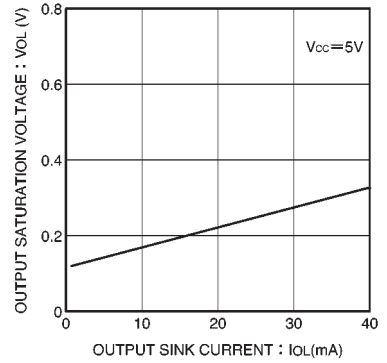

Fig. 12 Output saturation voltage vs. sink current (LED output)

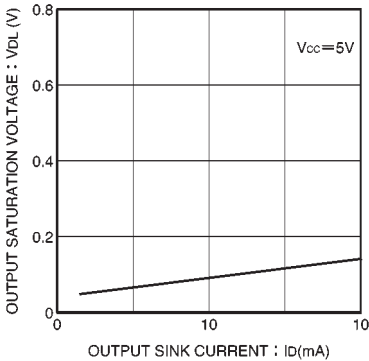

Fig. 13 Output saturation voltage vs. sink current (display switch output)

● External dimensions (Units: mm)

