

# 4-channel PRE / REC amplifier with auto-tracking interface

## BA7184S

The BA7184S is a PRE / REC amplifier developed for use in video cassette recorders. It is compatible with four-head decks and features built-in FB damping, four preamplifiers, a chroma output amplifier, an FM output amplifier (with AGC), an envelope detector and envelope comparator, a constant-current BTL-drive REC amplifier (with AGC) and channel switching, EP / SP switching, and mode switching integrated onto a single monolithic IC.

### ●Applications

VCRs

### ●Features

- 1) The playback amplifier has a total gain of 56dB (Typ.), and has a low-noise preamplifier. Designed for VHS band operation with low external parts count. The IC has 4 circuits for 4-head VCR applications.
- 2) Two playback output systems (through output and AGC output). The AGC output level is 315mV<sub>P-P</sub> (Typ.); suitable for FM brightness signal output.
- 3) Auto-tracking interface for automated tracking adjustment. Linear detector characteristic with sensitivity that can be set using external components.
- 4) The recording amplifier uses constant-current BLT drive that handles load variations (i.e. headimpedance) well, and gives stable recording characteristics. 2 circuits are provided for 4-head VCR use.
- 5) Built-in recording level AGC means adjustment of FM recording current is not necessary.
- 6) Head switches for 4-channel PRE / REC system provided.
- 7) Operates off a single 5V power supply, with low power dissipation.

### ●Absolute maximum ratings (Ta = 25°C)

Parameter	Symbol	Limits	Unit
Applied voltage	V <sub>CC</sub>	7.0	V
Power dissipation	P <sub>d</sub>	1050*1	mW
Operating temperature	T <sub>opr</sub>	- 20 ~ + 65	°C
Storage temperature	T <sub>stg</sub>	- 55 ~ + 125	°C

\*1 Reduced by 10.5mW for each increase in Ta of 1°C over 25°C (free air).

### ●Recommended operating conditions (Ta = 25°C)

Parameter	Symbol	Min.	Typ.	Max.	Unit	Conditions
Playback / recording	V <sub>CC</sub>	4.5	5.0	5.5	V	13pin

○ Not designed for radiation resistance.

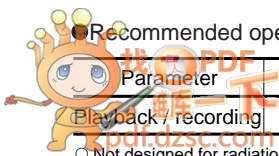

●Block diagram

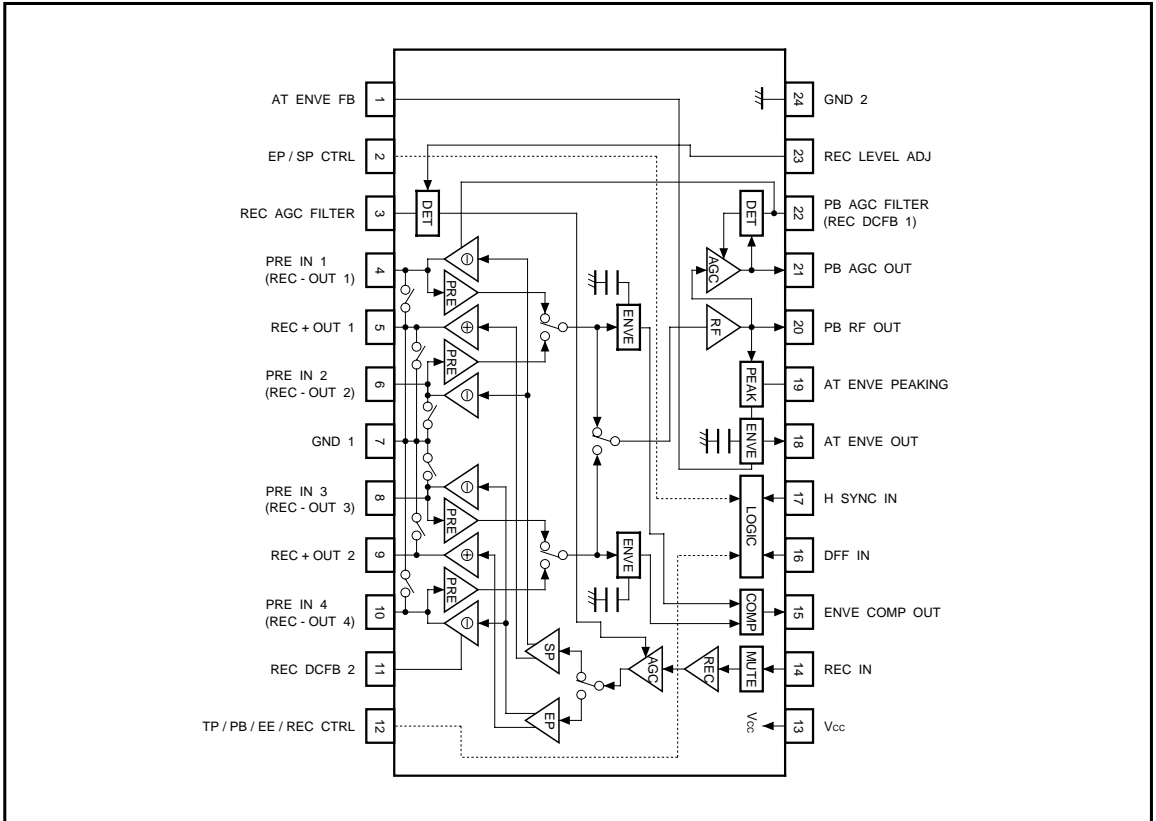

## ●Electrical characteristics (unless otherwise noted, Ta = 25°C, Vcc = 5.0V and f = 4.0MHz)

Parameter	Symbol	Min.	Typ.	Max.	Unit	Conditions	Measurement circuit
(Playback system) (Pin 12: H)							
Supply current	Iq (P)	—	27	45	mA	No signal	Fig. 1
Voltage gain ch-1	G <sub>VP1</sub>	52	56	60	dB	Pin 4 input = 0.3mV <sub>P-P</sub> , pin 2: L, pin 16: L, pin 20 output measurement	Fig. 1
Voltage gain ch-2	G <sub>VP2</sub>	52	56	60	dB	Pin 6 input = 0.3mV <sub>P-P</sub> , pin 2: L, pin 16: H, pin 20 output measurement	Fig. 1
Voltage gain ch-3	G <sub>VP3</sub>	52	56	60	dB	Pin 8 input = 0.3mV <sub>P-P</sub> , pin 2: H, pin 16: L, pin 20 output measurement	Fig. 1
Voltage gain ch-4	G <sub>VP4</sub>	52	56	60	dB	Pin 10 input = 0.3mV <sub>P-P</sub> , pin 2: H, pin 16: H, pin 20 output measurement	Fig. 1
Voltage gain differential	ΔG <sub>VP</sub>	-1.5	—	+1.5	dB	ΔG <sub>VP</sub> = G <sub>VP1</sub> - G <sub>VP2</sub> , G <sub>VP3</sub> - G <sub>VP4</sub>	Fig. 1
Frequency characteristic	ΔG <sub>Vf</sub>	-8	-1.7	—	dB	Pin 20 output level difference for f = 8.0 / 1.0MHz, V <sub>IN</sub> = 0.3mV <sub>P-P</sub> .	Fig. 1
2nd harmonic distortion	2HD <sub>P</sub>	—	-42	-35	dBc	V <sub>IN</sub> = 0.3mV <sub>P-P</sub> , 8.0MHz spurious	Fig. 1
3rd harmonic distortion	3HD <sub>P</sub>	—	-50	-35	dBc	V <sub>IN</sub> = 0.3mV <sub>P-P</sub> , 12.0MHz spurious* <sup>2</sup>	Fig. 1
Maximum output level	V <sub>OMP</sub>	0.8	1.2	—	V <sub>P-P</sub>	When pin 20 output 2nd harmonic distortion is -30dBc	Fig. 1
Crosstalk	CT <sub>P</sub>	—	-45	-30	dBc	Pin 20 output level difference for pin 2: H / L, pin 16: H / L.	Fig. 1
Output DC offset	ΔV <sub>ODC</sub>	—	—	200	mV <sub>P-P</sub>	Pin 20 output DC offset for pin 2: H / L, pin 16: H / L.	Fig. 1
Input conversion noise	V <sub>NIN</sub>	—	0.25	1.0	μVrms	Rg = 10Ω, input conversion of pin 20 output noise* <sup>2</sup>	Fig. 1
AGC output level	V <sub>AGC</sub>	265	315	365	mV <sub>P-P</sub>	V <sub>IN</sub> = 0.3mV <sub>P-P</sub> , pin 21 output measurement	Fig. 1
AGC control sensitivity	ΔV <sub>AGC</sub>	—	0.3	2.0	dB	Pin 21 output level differential for V <sub>IN</sub> = 0.15 to 0.6mV <sub>P-P</sub> .	Fig. 1
AGC frequency characteristic	ΔG <sub>VAF</sub>	-8	-3	—	dB	f = 8.0 / 1.0MHz, V <sub>IN</sub> = 0.3mV <sub>P-P</sub> * <sup>2</sup>	Fig. 1
PB switch ON resistance	R <sub>ONS, 9</sub>	—	5	10	Ω	Pin 5 and pin 9 impedance* <sup>2</sup>	Fig. 1
ENVE residual voltage	V <sub>ENV1</sub>	—	0.7	1.0	V	Pin 18 output measurement when no signal	Fig. 1
ENVE output level	V <sub>ENV2</sub>	2.4	2.9	3.4	V	Pin 18 output measurement when pin 20 output = 400mV <sub>P-P</sub>	Fig. 1
ENVE saturation voltage	V <sub>ENV3</sub>	4.0	4.5	—	V	Pin 18 output measurement for large signal	Fig. 1
PRE ch 2 and 4 holding voltage	V <sub>TH16H</sub>	3.5	—	V <sub>CC</sub>	V	Pin 16 DC voltage for ch 2 and 4 operation	Fig. 1
PRE ch 1 and 3 holding voltage	V <sub>TH16L</sub>	0	—	1.2	V	Pin 16 DC voltage for ch 1 and 3 operation	Fig. 1
EP mode holding voltage	V <sub>TH2H</sub>	3.5	—	V <sub>CC</sub>	V	Pin 2 DC voltage for EP mode	Fig. 1
SP mode holding voltage	V <sub>TH2L</sub>	0	—	1.2	V	Pin 2 DC voltage for SP mode	Fig. 1
TP mode holding voltage	V <sub>TH12T</sub>	4.1	—	V <sub>CC</sub>	V	Pin 12 DC voltage for TRICK PLAY mode	Fig. 1
PB mode holding voltage	V <sub>TH12H</sub>	3.0	—	3.7	V	Pin 12 DC voltage for PB mode	Fig. 1
EE mode holding voltage	V <sub>TH12M</sub>	1.1	—	2.6	V	Pin 12 DC voltage for REC MUTE mode	Fig. 1
REC mode holding voltage	V <sub>TH12L</sub>	0	—	0.7	V	Pin 12 DC voltage for REC mode	Fig. 1

\*<sup>2</sup> Guaranteed design values.

Note: dBc: dB below carrier (used to express relative level from carrier reference for convenience sake)

Parameter	Symbol	Min.	Typ.	Max.	Unit	Conditions	Measurement circuit
(Recording system) (Pin 12: L)							
Quiescent current	$I_{q(R)}$	—	67	100	mA	No signal	Fig. 2
Recording AGC level 1	$I_{OAR1}$	27	30	33	mA <sub>P-P</sub>	Pin 14 input = 125mV <sub>P-P</sub> , pin 2: L, pin 5 output measurement	Fig. 2
Recording AGC level 2	$I_{OAR2}$	24	27	30	mA <sub>P-P</sub>	Pin 14 input = 125mV <sub>P-P</sub> , pin 2: H, pin 9 output measurement	Fig. 2
AGC control sensitivity	$\Delta I_{OAR}$	—	0.3	2.0	dB	Pin 14 input = 62.5mV <sub>P-P</sub> , to 250mV <sub>P-P</sub> , pin 5 output level differential	Fig. 2
AGC frequency characteristic	$\Delta I_{OAF}$	-8	-3	—	dB	f = 8.0 / 1.0MHz, pin 14 input = 125mV <sub>P-P</sub> ,*2	Fig. 2
2nd harmonic distortion	2H <sub>DR</sub>	—	-45	-35	dBc	Pin 14 input = 125mV <sub>P-P</sub> , 8MHz spurious	Fig. 2
3rd harmonic distortion	3H <sub>DR</sub>	—	-50	-35	dBc	Pin 14 input = 125mV <sub>P-P</sub> , 12.0MHz spurious*2	Fig. 2
Cross modulation distortion	CMD <sub>R</sub>	—	-50	-35	dBc	4.0MHz ± 630kHz spurious*2	Fig. 2
Maximum output level	$I_{OMR}$	40	50	—	mA <sub>P-P</sub>	When pin 5 output 2nd harmonic distortion is -30dB	Fig. 2
Recording current load characteristic	$\Delta I_{ORL}$	-2.0	-0.3	—	dB	Pin 5 output level difference when load L: 8.2 and 12μH*2	Fig. 2
Mute attenuation ratio	MU <sub>R</sub>	—	-45	-35	dBc	Pin 5 output level difference for pin 12: M / L	Fig. 2
AGC mode holding voltage	$V_{TH17H}$	2.8	—	$V_{CC}$	V	Pin 17 DC voltage to maintain recording AGC operation.	Fig. 2
AGC mode holding voltage	$V_{TH17L}$	0	—	1.2	V	Pin 17 DC voltage to maintain recording AGC stopped.	Fig. 2

\*2 Guaranteed design values.

Note: dBc: dB below carrier (used to express relative level from carrier reference for convenience sake)

● Measurement circuits  
(Playback system)

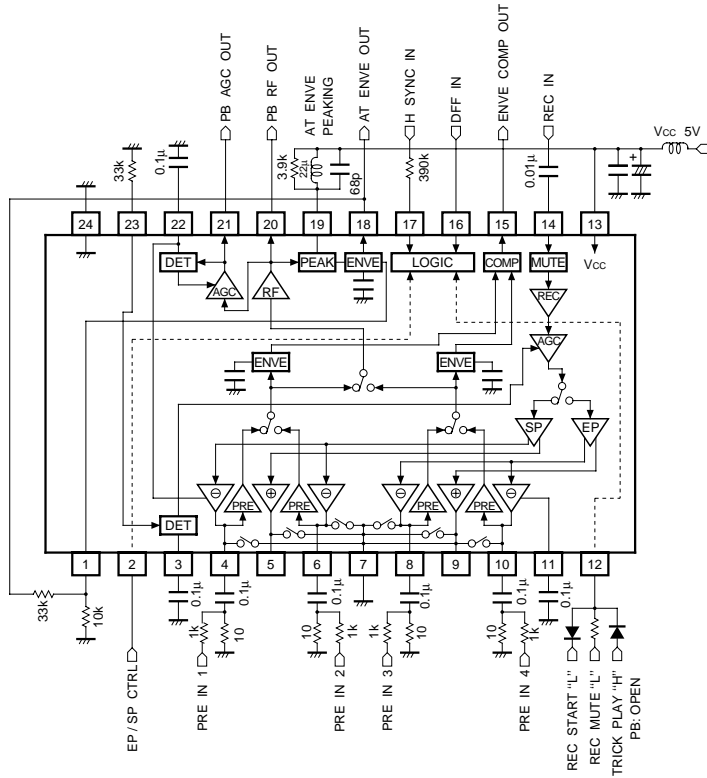

Units: R [Ω]  
C [F]  
L [H]

Fig. 1

(Recording system)

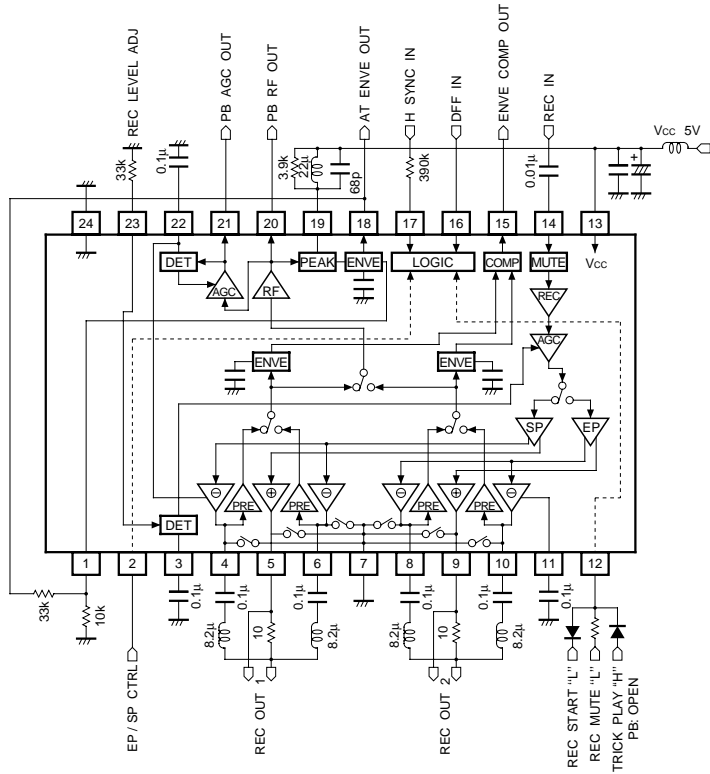

Units: R [Ω]  
C [F]  
L [H]

Fig. 2

●Control system logic table

(1) DFF IN (pin 16)

- Playback input selection (head switching)

Control pin		Function	Control voltage $V_{CTRL16}$ [V]
DFF IN	EP / SP	Selected playback input	
L	H	Ch3 (PRE IN3 8pin)	3.5 ~ $V_{CC}$
H		Ch4 (PRE IN4 10pin)	0.0 ~ 1.2
L	L	Ch1 (PRE IN1 4pin)	—
H		Ch2 (PRE IN2 6pin)	—

(2) EP / SP control (pin 2)

- Recording output selection
- Playback input selection (see (1))

Control pin		Function	Control voltage $V_{CTRL2}$ [V]
EP / SP		Selected recording output	
H		EP (REC OUT 8, 9, 10pin)	3.5 ~ $V_{CC}$
L		SP (REC OUT 4, 5, 6pin)	0.0 ~ 1.2

(3) TP / PB / EE / REC CTRL (pin 12)

- Special playback / playback / recording mute / recording mode switching

Control pin	Mode	Function					Control voltage $V_{CTRL12}$ [V]
		PRE AMP	AT ENVE	ENV COMP	REC MUTE	REC AMP	
OT	TRICK PLAY	ON	ON	ON	OFF	OFF	4.1 ~ $V_{CC}$
H	PB	ON	ON	OFF	OFF	OFF	3.0 ~ 3.7
M	REC MUTE	OFF	OFF	OFF	ON	ON	1.1 ~ 2.6
L	REC	OFF	OFF	OFF	OFF	ON	0.0 ~ 0.7

- Pin 12 is biased internally in the IC. When open, PB mode is selected.

(4) H SYNC IN (pin 17)

- Special playback envelope comparator (ENVE COMP) output latch control.
- AGC operation control for recording.

Control pin		Function		Control voltage $V_{CTRL17}$ [V]
H SYNC		ENVE COMP	AGC detector	
H		Set at falling edge	ON	2.8 ~ $V_{CC}$
L		—	OFF	0.0 ~ 1.2

(5) ENVE COMP OUT (pin 15)

- Outputs playback envelope comparator data for special playback.

Control pin	Function
ENVE COMP	Playback input level
H	Ch1 or Ch2 > Ch3 or Ch4
L	Ch1 or Ch2 < Ch3 or Ch4

●Application example

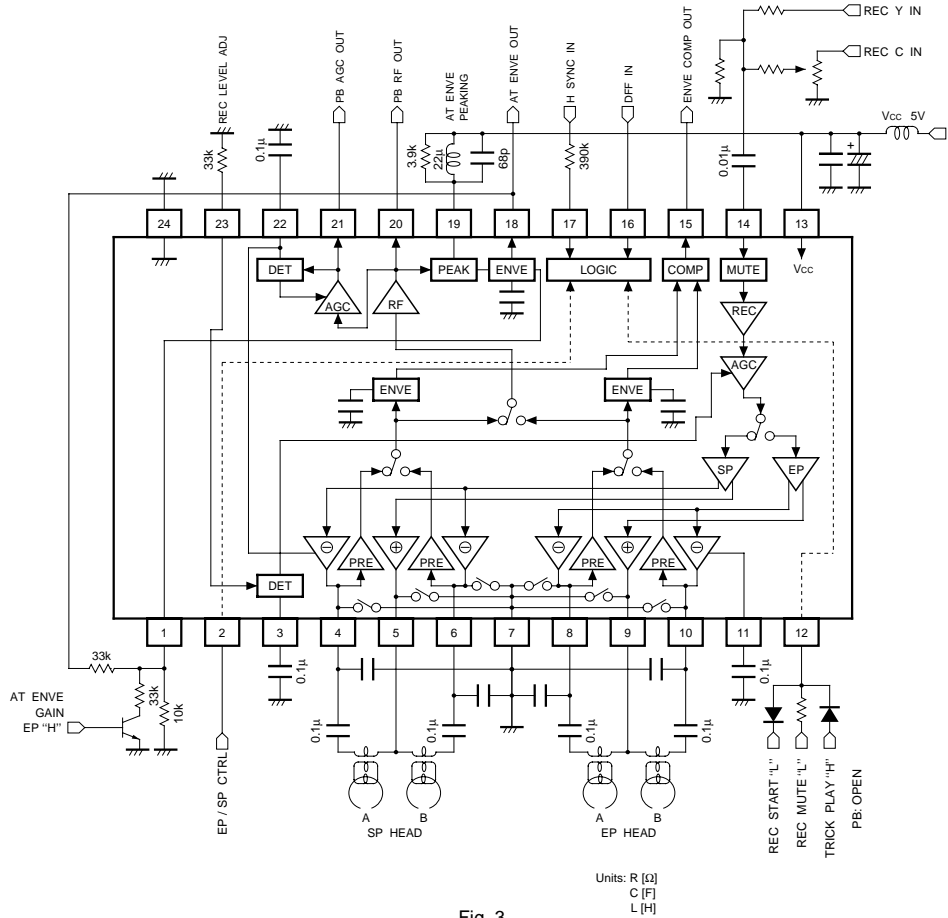

Fig. 3

●External dimensions (Units: mm)

