

# Video signal switcher

## BA7604N

The BA7604N is a switching IC developed for use in VCRs. It has two-channel analog multiplexers, and features wide dynamic range, and wide operating frequency range, and is suitable for switching audio and video signals.

●Applications  
VCRs and TVs

●Features

- 1) Two 2-input / 1-output switches.
- 2) 5V power supply.
- 3) Low power consumption (42mW Typ.).
- 4) Excellent frequency characteristics (10MHz, 0dB, Typ.).
- 5) Wide dynamic range (3.0V<sub>P-P</sub> Typ.).
- 6) High input impedance (20kΩ Typ.).
- 7) Fast switching speed (50ns Typ.).

●Absolute maximum ratings (Ta = 25°C)

Parameter	Symbol	Limits	Unit
Power supply voltage	V <sub>cc</sub>	9	V
Power dissipation	P <sub>d</sub>	500*	mW
Operating temperature	T <sub>opr</sub>	- 40 ~ + 85	°C
Storage temperature	T <sub>stg</sub>	- 55 ~ + 125	°C

\* Reduced by 5.0mW for each increase in Ta of 1°C over 25°C.

●Block diagram

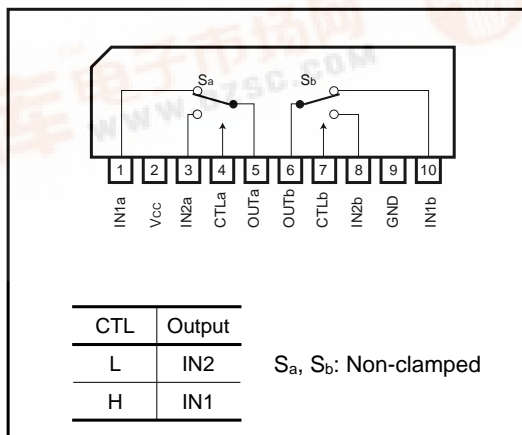

●Equivalent circuits

Sa, Sb

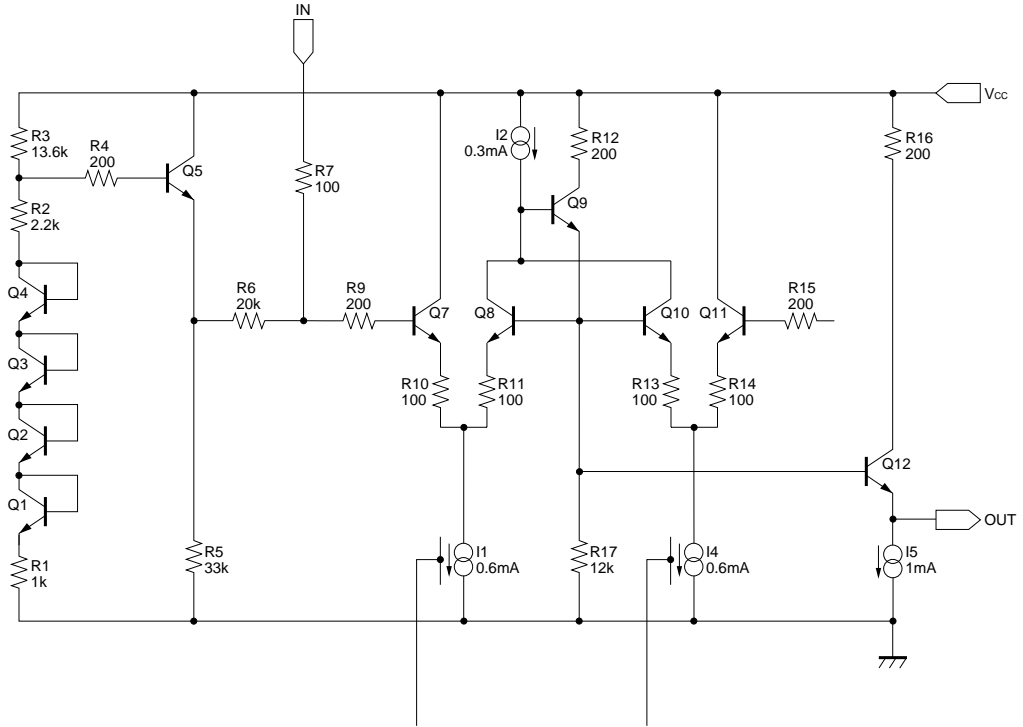

CTL

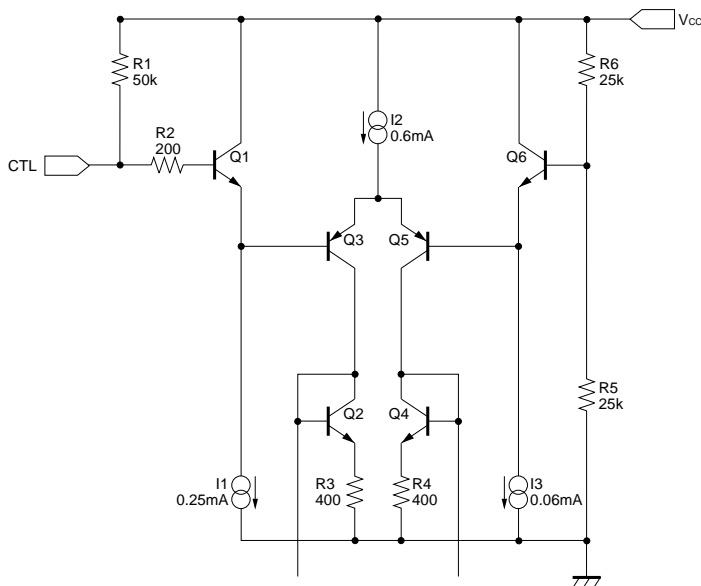

●Electrical characteristics (unless otherwise noted, Ta = 25°C and V<sub>CC</sub> = 5.0V)

Parameter	Symbol	Min.	Typ.	Max.	Unit	Conditions
Operating voltage	V <sub>CC</sub>	4.5	5.0	5.5	V	—
Supply current	I <sub>CC</sub>	—	8.4	13.0	mA	—
Maximum output level	V <sub>om</sub>	2.7	3.0	—	V <sub>P-P</sub>	f = 1kHz, THD = 0.5%
Voltage gain	G <sub>V</sub>	-0.5	0	0.5	dB	f = 1MHz, V <sub>IN</sub> = 1V <sub>P-P</sub>
Interchannel crosstalk	C <sub>T</sub>	—	-65	—	dB	f = 4.43MHz, V <sub>IN</sub> = 1V <sub>P-P</sub>
Frequency characteristic	G <sub>f</sub>	-3	0	1	dB	10MHz / 1MHz, V <sub>IN</sub> = 1V <sub>P-P</sub>
Total-harmonic distortion	THD	—	0.007	—	%	f = 1MHz, V <sub>IN</sub> = 1V <sub>P-P</sub>
CTL pin switch level	V <sub>TH</sub>	2.0	2.5	3.0	V	—
Input impedance	Z <sub>IN</sub>	14	20	26	kΩ	—

Note: Refer to the measurement circuit given in Fig. 1.

●Reference data

Pin DC voltages (reference values)

Units: V<sub>dc</sub>

Pin No.	DC voltage	Pin No.	DC voltage
1	2.48	6	1.76
2	5.00	7	4.91
3	2.48	8	2.48
4	4.91	9	0
5	1.76	10	2.48

Electrical characteristics

Parameter	Min.	Typ.	Max.	Unit
Input impedance (no clamp)	—	20k	—	Ω
Output impedance	—	30	—	Ω

The input coupling capacitor values should be 0.1μF to 1μF.

● Measurement circuit

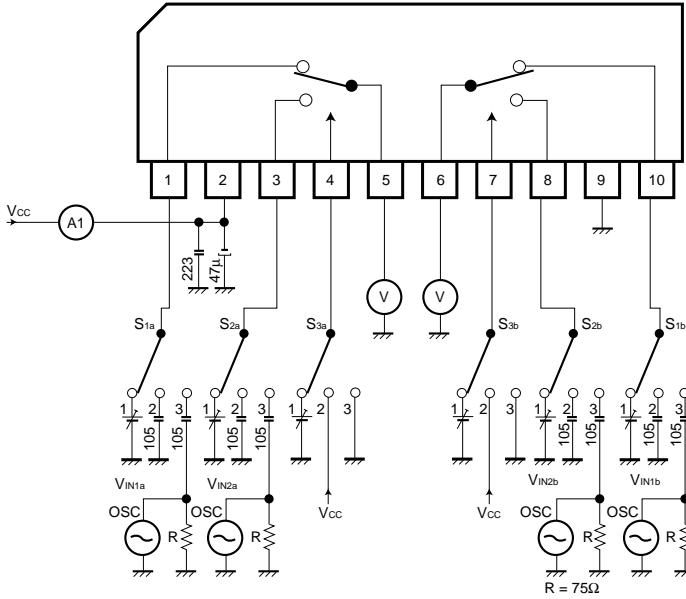

●Measurement conditions

Parameter		Symbol	Switch settings						Measurement method
			S1a	S2a	S3a	S1b	S2b	S3b	
Current dissipation		I <sub>CC</sub>	2	2	2	2	2	2	Ammeter
Maximum output level	I <sub>N1a</sub>	V <sub>om</sub>	3	2	2	2	2	2	Note 1
	I <sub>N2a</sub>	V <sub>om</sub>	2	3	3	2	2	2	
	I <sub>N1b</sub>	V <sub>om</sub>	2	2	2	3	2	2	
	I <sub>N2b</sub>	V <sub>om</sub>	2	2	2	2	3	3	
Voltage gain	I <sub>N1a</sub>	G <sub>V</sub>	3	2	2	2	2	2	Note 2
	I <sub>N2a</sub>	G <sub>V</sub>	2	3	3	2	2	2	
	I <sub>N1b</sub>	G <sub>V</sub>	2	2	2	3	2	2	
	I <sub>N2b</sub>	G <sub>V</sub>	2	2	2	2	3	3	
Interchannel crosstalk	I <sub>N1a</sub>	C <sub>T</sub>	2	3	2	2	2	2	Note 3
	I <sub>N2a</sub>	C <sub>T</sub>	3	2	3	2	2	2	
	I <sub>N1b</sub>	C <sub>T</sub>	2	2	2	2	3	2	
	I <sub>N2b</sub>	C <sub>T</sub>	2	2	2	3	2	3	
Frequency characteristic	I <sub>N1a</sub>	G <sub>f</sub>	3	2	2	2	2	2	Note 4
	I <sub>N2a</sub>	G <sub>f</sub>	2	3	3	2	2	2	
	I <sub>N1b</sub>	G <sub>f</sub>	2	2	2	3	2	2	
	I <sub>N2b</sub>	G <sub>f</sub>	2	2	2	2	3	3	
CTL pin switching level	CTL <sub>a</sub>	V <sub>TH</sub>	3	2	1	2	2	2	Note 5
	CTL <sub>b</sub>	V <sub>TH</sub>	2	2	2	3	2	1	
Total-harmonic distortion	I <sub>N1a</sub>	THD	3	2	2	2	2	2	Note 6
	I <sub>N2a</sub>	THD	2	3	3	2	2	2	
	I <sub>N1b</sub>	THD	2	2	2	3	2	2	
	I <sub>N2b</sub>	THD	2	2	2	2	3	3	
Input impedance	I <sub>N1a</sub>	Z <sub>IN</sub>	1	2	2	2	2	2	Note 7
	I <sub>N2a</sub>	Z <sub>IN</sub>	2	1	3	2	2	2	
	I <sub>N1b</sub>	Z <sub>IN</sub>	2	2	2	1	2	2	
	I <sub>N2b</sub>	Z <sub>IN</sub>	2	2	2	2	1	3	

Note 1: Connect a distortion meter to the output, and input a f = 1kHz sine wave. Adjust the output level until the output distortion is 0.5%. This output voltage at this time is the maximum output level V<sub>om</sub> (V<sub>P-P</sub>).

Note 2: Input a 1V<sub>P-P</sub>, 1MHz sine wave. The voltage gain is given by G<sub>V</sub> = 20 log (V<sub>OUT</sub> / V<sub>IN</sub>).

Note 3: Input a 1V<sub>P-P</sub>, 4.43MHz sine wave. The interchannel crosstalk is given by C<sub>T</sub> = 20 log (V<sub>OUT</sub> / V<sub>IN</sub>).

Note 4: Input 1V<sub>P-P</sub>, 1MHz and 10MHz sine waves. The frequency characteristic is given by G<sub>f</sub> = 20 log (V<sub>OUT</sub> (f = 10MHz) / V<sub>OUT</sub> (f = 1MHz)).

Note 5: Input a 1V<sub>P-P</sub>, 1MHz sine wave. Reduce the CTL pin voltage from V<sub>CC</sub>. The CTL pin switching level (V<sub>TH</sub>) is the CTL pin voltage at which the V<sub>OUT</sub> level drops below 20mV<sub>P-P</sub>.

Note 6: Input a 1V<sub>P-P</sub>, 1kHz sine wave and measure the total-harmonic distortion of the output using a total-harmonic distortion meter.

Note 7: Measure the input pin voltage V<sub>IN50</sub> when a current of DC50μA is flowing into the input pin. Measure the input pin open-circuit voltage. The input impedance is given by Z = (V<sub>IN50</sub> - V<sub>IN0</sub>) / 50 × 10<sup>-6</sup>[Ω].

●External dimensions (Units: mm)

