

Video signal switcher

BA7606 / BA7606F

The BA7606 and BA7606F are switching ICs developed for use in video cameras. Each contains three two-channel analog multiplexers. They feature a large dynamic range, and wide operating frequency range, and the switches have pedestal clamp inputs which are ideal for switching RGB and video signals.

●Applications

Video cassette recorders and televisions

●Features

- 1) Three 2-input / 1-output switches.
- 2) 5V power supply.
- 3) Pedestal clamp inputs
- 4) Low power consumption (62.5mW Typ.).
- 5) Excellent frequency characteristics (10MHz, -1dB Typ.).
- 6) Wide dynamic range (2.6Vp-p Typ.).
- 7) Fast switching speed (50ns Typ.).

●Block diagram

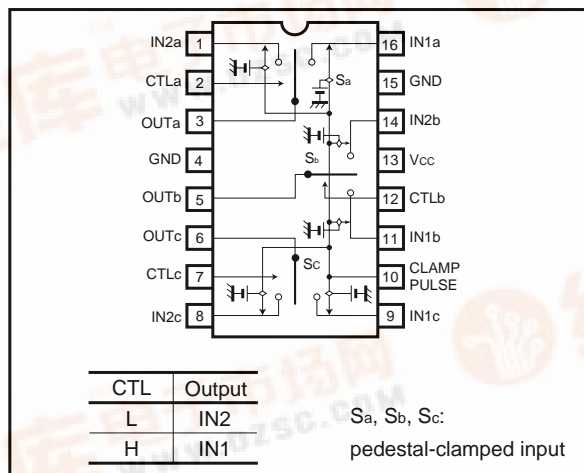

●Absolute maximum ratings (Ta = 25°C)

Parameter	Symbol	Limits	Unit
Power supply voltage	Vcc	9	V
Power dissipation	Pd	500*	mW
Operating temperature	Topr	-40 ~ +85	°C
Storage temperature	Tstg	-55 ~ +125	°C

* Reduced by 5.0mW for each increase in Ta of 1°C over 25°C.

●Equivalent circuits

Sa, Sb, Sc

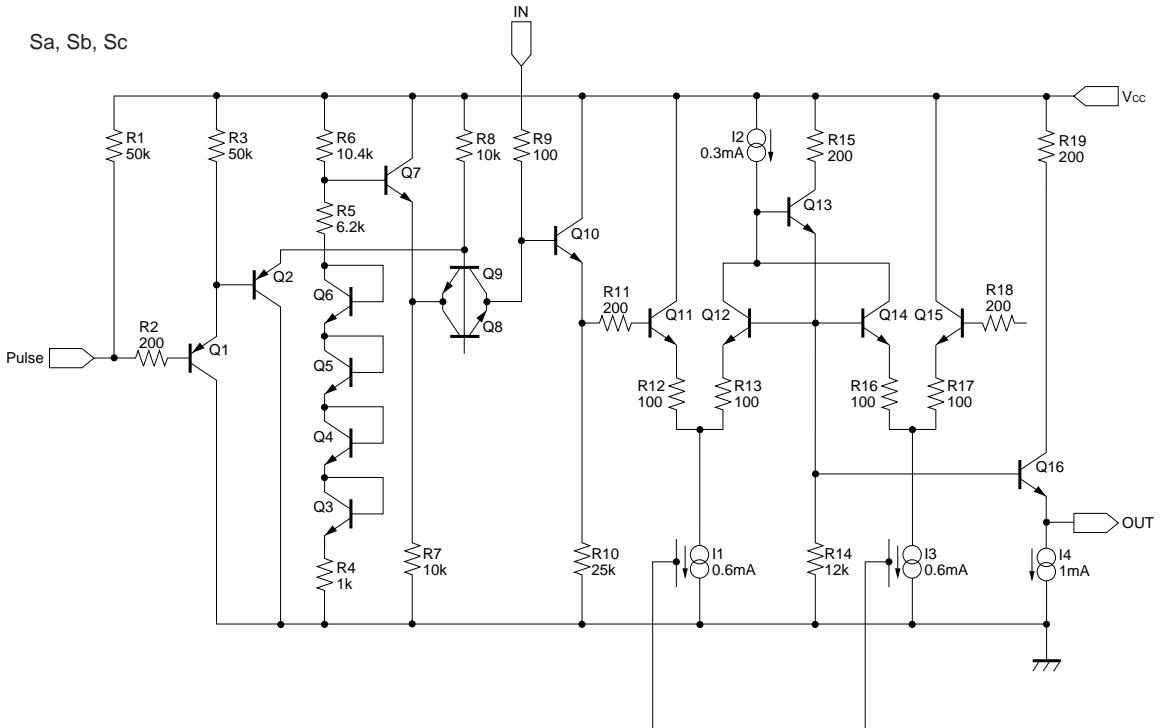

CTL

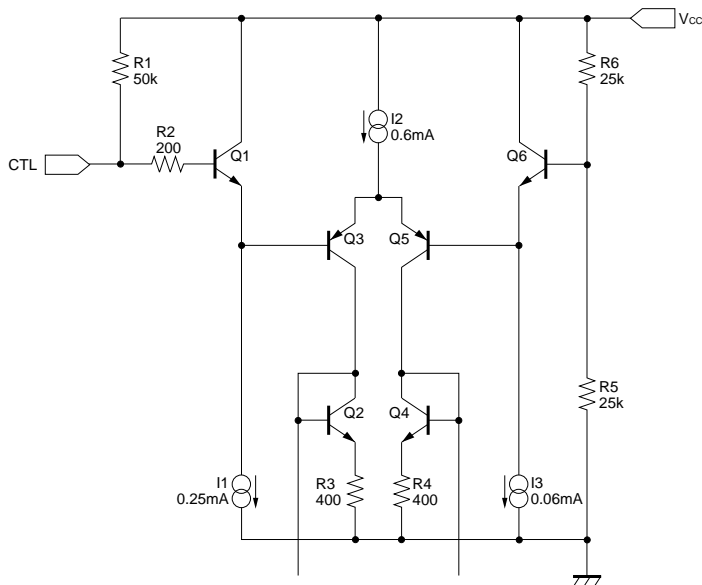

●Electrical characteristics (unless otherwise noted, Ta = 25°C and Vcc = 5V)

Parameter	Symbol	Min.	Typ.	Max.	Unit	Conditions
Operating voltage	V _{CC}	4.5	5.0	5.5	V	—
Supply current	I _{CC}	—	15.0	23.0	mA	—
Maximum output level U	V _{omU}	1.40	1.65	—	V _{P-P}	Note 1
Maximum output level D	V _{omD}	0.80	0.95	—	V _{P-P}	Note 2
Voltage gain	G _V	- 0.9	0	0.5	dB	f = 1MHz, V _{IN} = 1V _{P-P}
Interchannel crosstalk	C _T	—	- 65	—	dB	f = 4.43MHz, V _{IN} = 1V _{P-P}
Frequency characteristics	G _f	- 3	- 1	1	dB	10MHz / 1MHz, V _{IN} = 1V _{P-P}
CTL pin switch level	V _{TH}	2.0	2.5	3.0	V	—
Clamp input level	V _{ct}	0.75	—	2.2	V	—

* Refer to the measurement circuit given in Fig. 1.

Note 1: Positive-side dynamic range from the clamp level

Note 2: Negative-side dynamic range from the clamp level

●Reference date

Pin DC voltages (reference values)

Units: V_{dc}

Pin No.	DC voltage	Pin No.	DC voltage
1	2.96	9	2.96
2	4.91	10	4.97
3	1.54	11	2.96
4	0	12	4.91
5	1.54	13	5.00
6	1.54	14	2.96
7	4.91	15	0
8	2.96	16	2.96

Electrical characteristics

Parameter	Min.	Typ.	Max.	Unit
Pedestal clamp level	1.20	1.54	1.95	V _{dc}
Input impedance (with clamp)	—	1.7M	—	Ω
Output impedance*	—	30	—	Ω

The input coupling capacitor values should be 0.1μF to 1μF.

Use a clamp pulse of at least 1μS (BA7606).

* The pin 6 output impedance of the BA7606 is 130Ω

● Measurement circuit

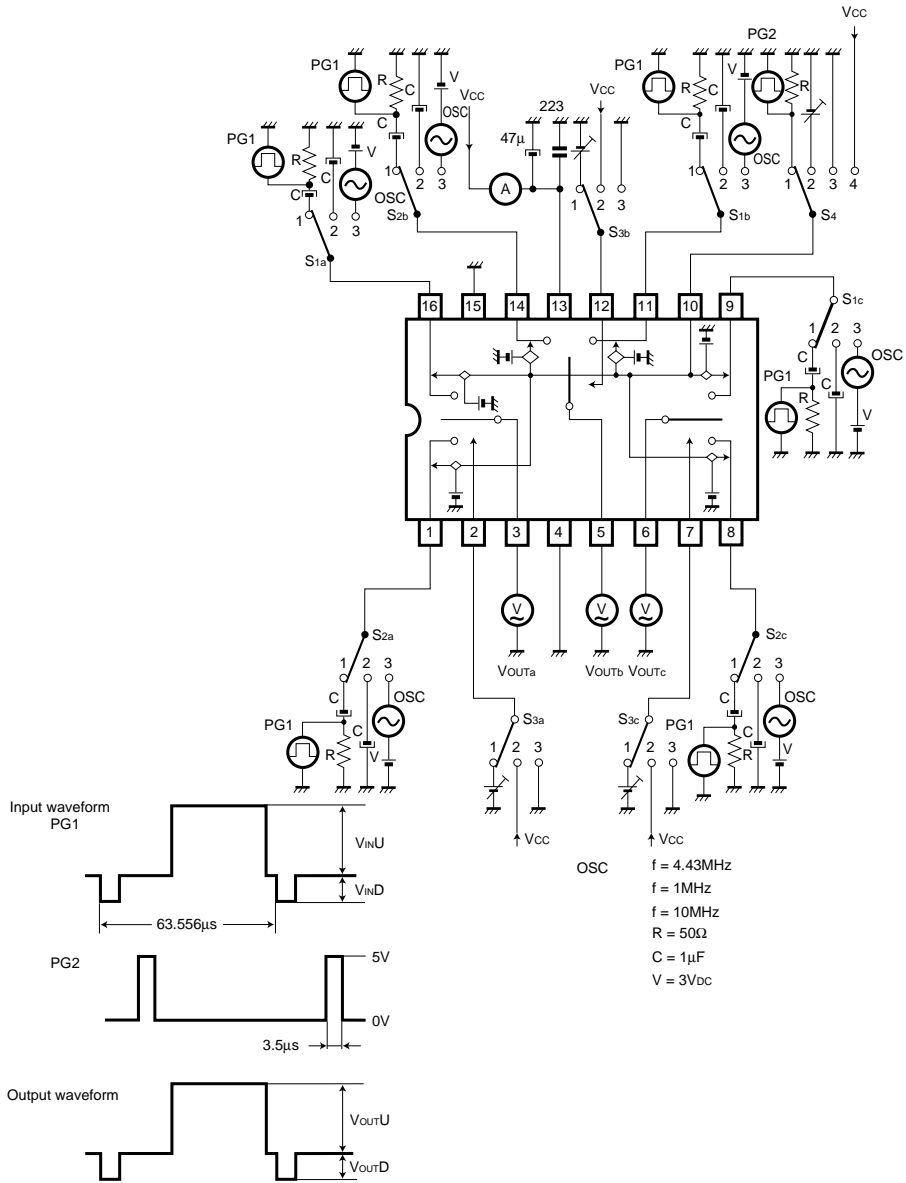

Fig.1

● Measurement conditions

Parameter		Symbol	Switch settings										Measurement method
			S _{1a}	S _{2a}	S _{3a}	S _{1b}	S _{2b}	S _{3b}	S _{1c}	S _{2c}	S _{3c}	S _{4c}	
Current dissipation		I _{CC}	2	2	2	2	2	2	2	2	2	4	Ammeter
Maximum output level (U or D)	IN1a	V _{om}	1	2	2	2	2	2	2	2	2	1	Note 1
	IN2a	V _{om}	2	1	3	2	2	2	2	2	2	1	
	IN1b	V _{om}	2	2	2	1	2	2	2	2	2	1	
	IN2b	V _{om}	2	2	2	2	1	3	2	2	2	1	
	IN1c	V _{om}	2	2	2	2	2	2	1	2	2	1	
	IN2c	V _{om}	2	2	2	2	2	2	2	1	3	1	
Voltage gain	IN1a	G _V	3	2	2	2	2	2	2	2	2	3	OSC f = 1MHz V _{IN} = 1V _{P-P} Note 2
	IN2a	G _V	2	3	3	2	2	2	2	2	2	3	
	IN1b	G _V	2	2	2	3	2	2	2	2	2	3	
	IN2b	G _V	2	2	2	2	3	3	2	2	2	3	
	IN1c	G _V	2	2	2	2	2	2	3	2	2	3	
	IN2c	G _V	2	2	2	2	2	2	2	3	3	3	
Inter-channel crosstalk	IN1a	C _T	2	3	2	2	2	2	2	2	2	3	OSC f = 4.43MHz V _{IN} = 1V _{P-P} Note 3
	IN2a	C _T	3	2	3	2	2	2	2	2	2	3	
	IN1b	C _T	2	2	2	2	3	2	2	2	2	3	
	IN2b	C _T	2	2	2	3	2	3	2	2	2	3	
	IN1c	C _T	2	2	2	2	2	2	2	3	2	3	
	IN2c	C _T	2	2	2	2	2	2	3	2	3	3	
Frequency characteristic	IN1a	G _f	3	2	2	2	2	2	2	2	2	3	OSC f = 10MHz f = 1MHz V _{IN} = 1V _{P-P} Note 4
	IN2a	G _f	2	3	3	2	2	2	2	2	2	3	
	IN1b	G _f	2	2	2	3	2	2	2	2	2	3	
	IN2b	G _f	2	2	2	2	3	3	2	2	2	3	
	IN1c	G _f	2	2	2	2	2	2	3	2	2	3	
	IN2c	G _f	2	2	2	2	2	2	2	3	3	3	
CTL pin switching level	CTLa	V _{TH}	3	2	1	2	2	2	2	2	2	3	OSC f = 1MHz V _{IN} = 1V _{P-P} Note 5
	CTLb	V _{TH}	2	2	2	3	2	1	2	2	2	3	
	CTLc	V _{TH}	2	2	2	2	2	2	3	2	1	3	
Clamp pin	Clamp	V _{ct}	2	2	2	2	2	2	2	2	2	2	Note 6

Note 1: V_{omU} is the value for V_{OUTU} when V_{OUTU} / V_{INU} ≤ -1dB.

V_{omD} is the value for V_{OUTD} when V_{OUTD} / V_{IND} ≤ -1dB.

Note 2: G_V = 20 log (V_{OUT} / V_{IN}).

Note 3: C_T = 20 log (V_{OUT} / V_{IN}).

Note 4: G_f = 20 log (V_{OUT} (f = 10MHz) / V_{OUT} (f = 1MHz)).

Note 5: Reduce the CTL pin voltage from V_{CC}. The CTL pin switching level (V_{TH}) is the CTL pin voltage at which the V_{OUT} level drops below 20mV_{P-P}.

Note 6: Clamp pulse voltage at which V_{OUT} falls below 0.4V and clamp pulse voltage at which V_{OUT} falls below 1.4V.

● External dimensions (Units: mm)

BA7606

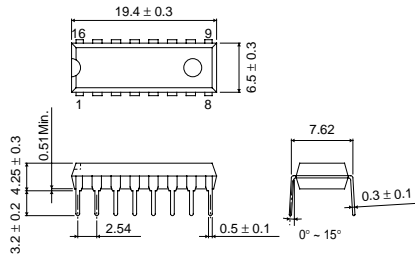

DIP16

BA7606F

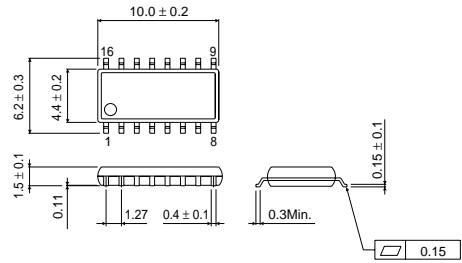

SOP16