

Input selector switch for high definition displays

BA7657F / BA7657S

The BA7657F and BA7657S are for high definition displays, and have internal switches for switching between broadband RGB signals and HD / VD signals, as well as an internal synchronization separator. These ICs simplify the designing of input units for deluxe displays.

●Applications

CRT display, HDTV, video board for personal computer, etc.

●Features

- 1) Operates on a single 5V power supply.
- 2) Internal broadband RGB switch (frequency characteristics: 230MHz, - 3dB).
- 3) Internal HD / VD switch.
- 4) Internal synchronization separator for synchronizing signals superimposed onto G signals.

●Absolute maximum ratings (Ta = 25°C)

Parameter	Symbol	Limits	Unit
Power supply voltage	Vcc	8.0	V
Power dissipation	BA7657F	550*	mW
	BA7657S	1200*	
Operating temperature	Topr	- 25 ~ + 75	°C
Storage temperature	Tstg	- 55 ~ + 125	°C

* Reduced by 5.5mW (BA7657F) or 12mW (BA7657S) for each increase in Ta of 1°C over 25°C.

●Recommended operating conditions (Ta = 25°C)

Parameter	Symbol	Min.	Typ.	Max.	Unit
Power supply voltage	Vcc	4.5	5.0	5.5	V



●Block diagram

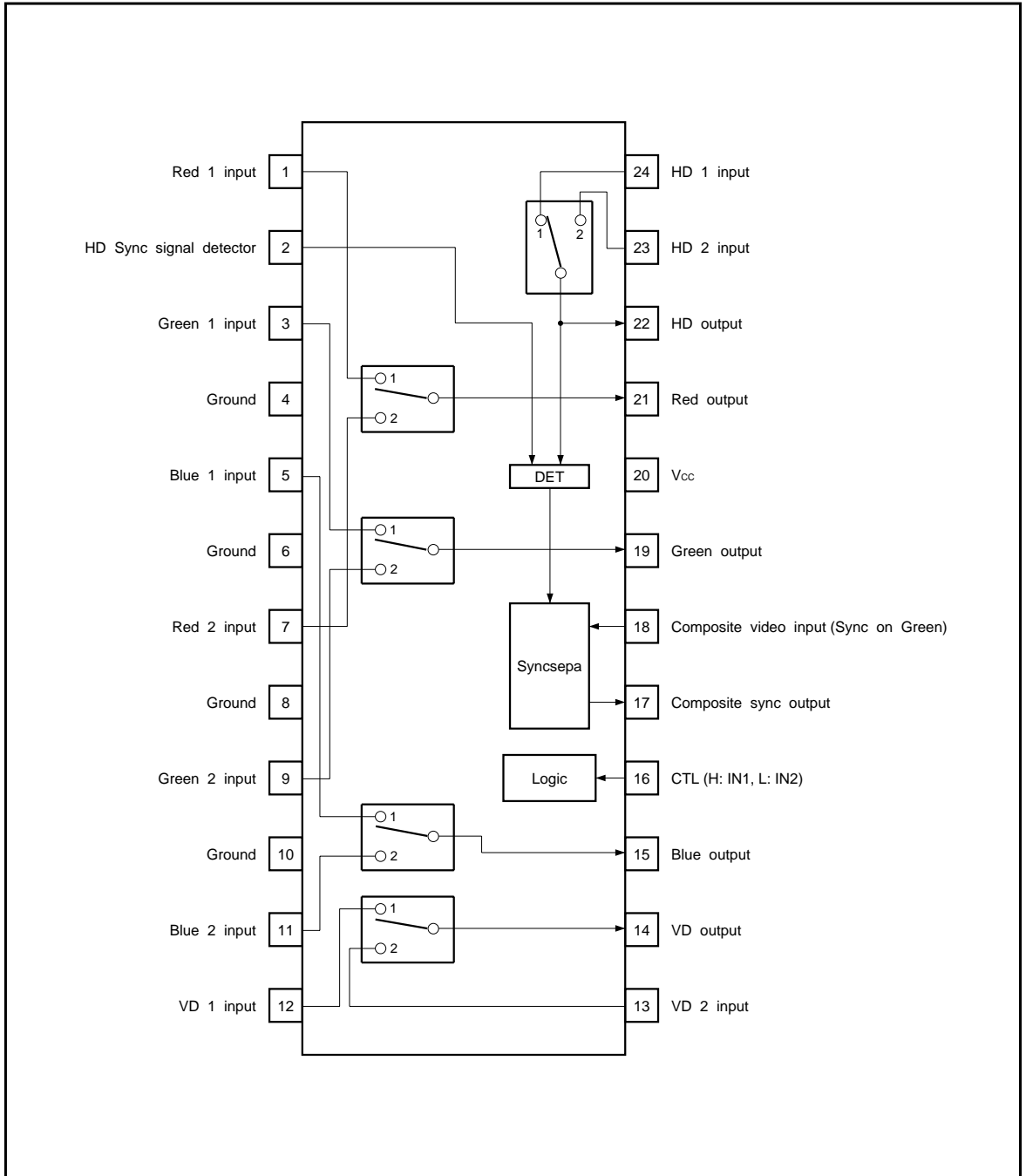

●Pin descriptions

Pin No.	Pin name	Function
1	Red 1 input	Color signal R1 input
2	HD Sync signal detector	Detecting phase of the synchronization signal detector circuit
3	Green 1 input	Color signal G1 input
4	Ground	Ground
5	Blue 1 input	Color signal B1 input
6	Ground	Ground
7	Red 2 input	Color signal R2 input
8	Ground	Ground
9	Green 2 input	Color signal G2 input
10	Ground	Ground
11	Blue 2 input	Color signal B2 input
12	VD 1 input	Vertical synchronization signal VD1 input
13	VD 2 input	Vertical synchronization signal VD2 input

Pin No.	Pin name	Function
14	VD output	Vertical synchronization signal VD output
15	Blue output	Color signal B output
16	Control	Control (high = IN1, low = IN2)
17	Composite sync output	Synchronization signal output
18	Composite video input	Composite signal input (Sync on Green)
19	Green output	Color signal G output
20	V _{cc}	Power supply
21	Red output	Color signal R output
22	HD output	Horizontal synch. signal HD output
23	HD 2 input	Horizontal synch. signal HD2 input
24	HD 1 input	Horizontal synch. signal HD1 input

●Output selection setting table

CTL	R	G	B	HD	VD
H	IN1	IN1	IN1	IN1	IN1
L	IN2	IN2	IN2	IN2	IN2

●Input / output circuits

R. G. B input

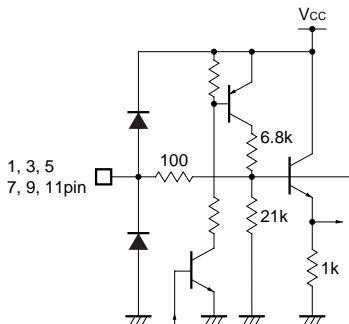

R. G. B output

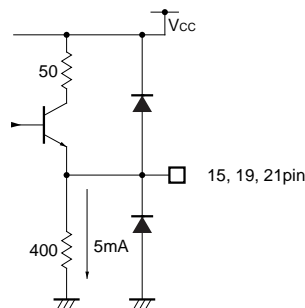

HD, VD input

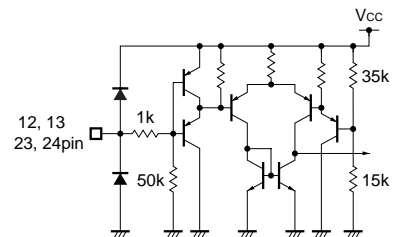

HD. VD output

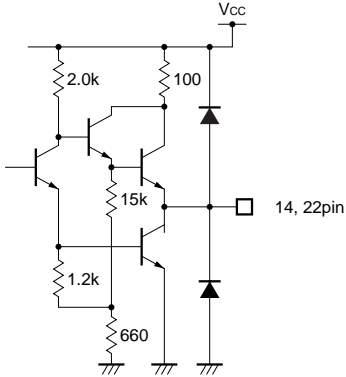

Control

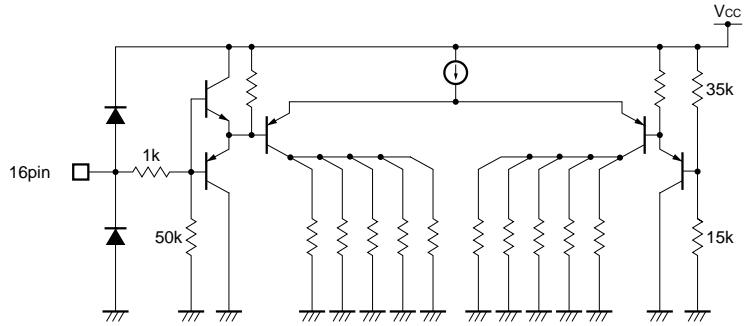

HD sync signal detector

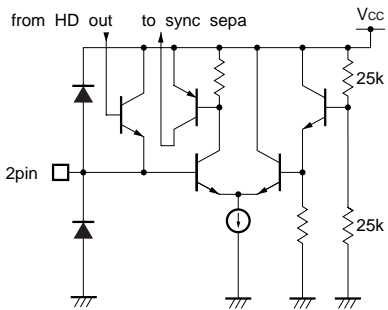

Composite Video input

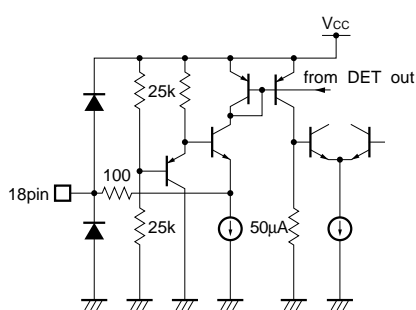

Composite Sync output

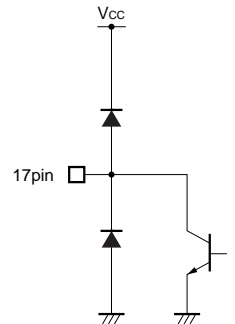

●Electrical characteristics (unless otherwise noted, Ta = 25°C, Vcc = 5.0V)

Parameter	Symbol	Min.	Typ.	Max.	Unit	Conditions	Measurement circuit
Quiescent current	I _{CC}	20	35	50	mA		Fig.1
〈Analog switch unit〉							
Maximum output level	V _{om}	2.8	—	—	V _{P-P}	f = 1kHz	Fig.1
Voltage gain	G _V	-1.0	-0.5	0	dB	f = 1MHz, V _{IN} = 1V _{P-P}	Fig.1
Input pin voltage gain deviation	ΔG _{V1}	-0.2	0	0.2	dB	f = 1MHz, V _{IN} = 1V _{P-P}	Fig.1
Block voltage gain deviation	ΔG _{VB}	-0.2	0	0.2	dB	f = 1MHz, V _{IN} = 1V _{P-P}	Fig.1
Input pin crosstalk 1	CTI1	—	-50	-40	dB	f = 10MHz, V _{IN} = 1V _{P-P}	Fig.2
Block crosstalk 1	CTB1	—	-50	-40	dB	f = 10MHz, V _{IN} = 1V _{P-P}	Fig.2
〈Digital switch unit〉							
Input high level voltage	V _{IH}	1.8	—	—	V		Fig.1
Input low level voltage	V _{IL}	—	—	1.2	V		Fig.1
Input high level current	I _{IH}	80	100	130	μA	V _{IN} = 5.0V	Fig.1
Input low level current	I _{IL}	-3	-1	—	μA	V _{IN} = 0V	Fig.1
Rise time	T _R	—	30	50	ns		Fig.1
Fall time	T _F	—	30	50	ns		Fig.1
Rise delay time	T _{RD}	—	50	80	ns		Fig.1
Fall delay time	T _{FD}	—	30	50	ns		Fig.1
Output high level voltage	V _{OH}	3.0	3.7	—	V		Fig.1
Output low level voltage	V _{OL}	—	0.2	0.4	V		Fig.1
Output high level current	I _{OH}	-400	—	—	μA		Fig.1
Output low level current	I _{OL}	5	—	—	mA		Fig.1
〈SYNC separation unit〉							
Minimum SYNC separation level	V _{SMin.}	-50	—	50	mV _{P-P}		Fig.1
Output high level voltage	V _{OH}	4.5	5.0	—	V		Fig.1
Output low level voltage	V _{OL}	—	0.2	0.5	V		Fig.1
Output low level current	I _{OL}	2	—	—	mA		Fig.1
Rise time	T _R	—	80	130	ns		Fig.1
Fall time	T _F	—	30	80	ns		Fig.1
Rising delay time	T _{RD}	—	100	150	ns		Fig.1
Fall delay time	T _{FD}	—	100	150	ns		Fig.1
〈Control unit〉							
Output high level voltage	V _{IH}	1.8	—	—	V		Fig.1
Output low level voltage	V _{IL}	—	—	1.2	V		Fig.1
Output high level current	I _{IH}	80	100	130	μA	V _{IN} = 5.0V	Fig.1
Output low level current	I _{IL}	-3	-1	—	μA	V _{IN} = 0V	Fig.1

●Guaranteed design parameters (unless otherwise noted, Ta = 25°C, VCC = 5.0V)

Parameter	Symbol	Min.	Typ.	Max.	Unit	Conditions	Measurement circuit
〈Analog switch unit〉							
Input pin crosstalk 2	CTI2	—	-30	-15	dB	f = 230MHz, VIN = 1VP-P	Fig.2
Block crosstalk 2	CTB2	—	-30	-15	dB	f = 230MHz, VIN = 1VP-P	Fig.2
Frequency characteristic deviation	Gf	-6	-3	-1	dB	f = 1MHz / 230MHz, VIN = 1VP-P	Fig.2
Input pin frequency characteristic deviation	ΔGfI	-1	0	+1	dB	f = 1MHz / 100MHz, VIN = 1VP-P	Fig.2
Block frequency characteristic deviation	ΔGfB	-1	0	+1	dB	f = 1MHz / 100MHz, VIN = 1VP-P	Fig.2
〈SYNC separation unit〉							
SYNC separation frequency	fH-R	200	—	—	kHz	input waveform*1	Fig.3
SYNC separation pulse width 1	pwH1	3.0	—	—	μs	input waveform*2 fH = 20kHz	Fig.3
SYNC separation pulse width 2	pwH2	0.5	—	—	μs	input waveform*2 fH = 100kHz	Fig.3
SYNC separation pulse width 3	pwH3	0.3	—	—	μs	input waveform*2 fH = 200kHz	Fig.3
SYNC separation level 1	VS1	300	—	—	μs	input waveform*3 fH = 20kHz	Fig.3
SYNC separation level 2	VS2	100	—	—	μs	input waveform*3 fH = 100kHz	Fig.3
SYNC separation level 3	VS3	60	—	—	μs	input waveform*3 fH = 200kHz	Fig.3

Input waveform (input to pin 3 or 9 [see illustration to right], Ro = 240 Ω)

*1 Vs and pwH = variable. Vs and pwH are interrelated. Refer to characteristics graph.

*2 Vs = 130mV, pwH = variable

*3 pwH = 1 μs , Vs = variable

Duration of horizontal synchronization signal

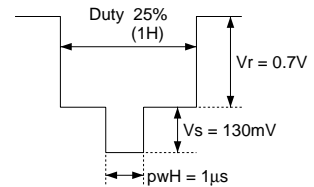

● Measurement circuit

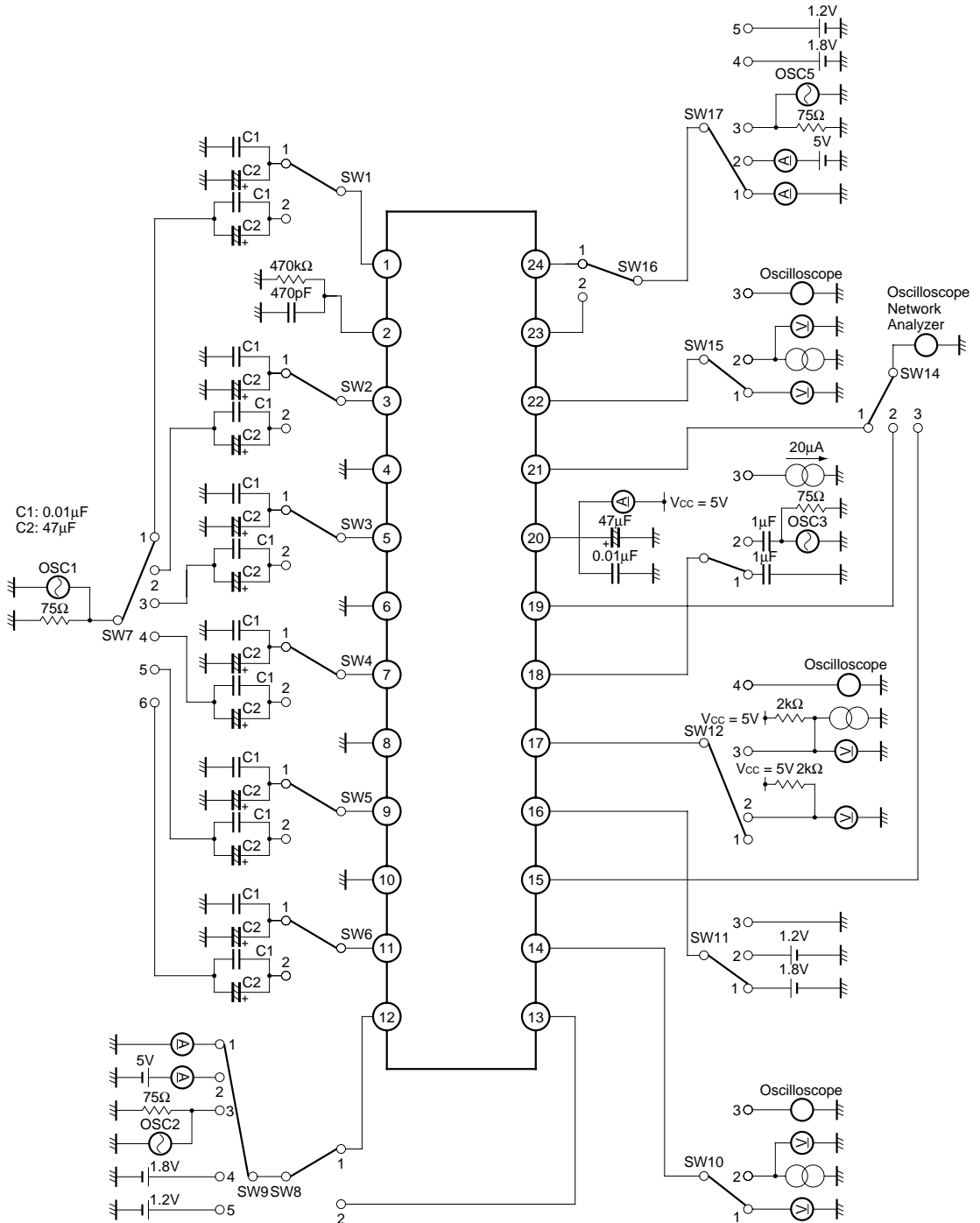

Fig. 1

●Electrical characteristic measurement conditions (1 / 2)

Parameter	Switch condition	
	11	Other
Supply current	3	1

《Analog switch unit》 (listings for color signal R switches only)

Parameter	Switch condition									
	1	2	3	4	5	6	7	11	14	Other
Maximum output level R1	2	1	1	1	1	1	1	1	1	1
Maximum output level R2	1	2	1	1	1	1	1	2	1	1
Voltage gain R1	2	1	1	1	1	1	1	1	1	1
Voltage gain R2	1	2	1	1	1	1	1	2	1	1

《Digital switch unit》 (listings for synchronization signal VD switches only)

Parameter	Switch condition							
	8	9	10	11	15	16	17	Other
Input voltage VD1, "H" level	1	4	1	1	1	1	1	1
Input voltage VD2, "H" level	2	4	1	2	1	1	1	1
Input voltage VD1, "L" level	1	5	1	1	1	1	1	1
Input voltage VD2, "L" level	2	5	1	2	1	1	1	1
Input current VD1, "H" level	1	2	1	1	1	1	1	1
Input current VD2, "H" level	2	2	1	2	1	1	1	1
Input current VD1, "L" level	1	1	1	1	1	1	1	1
Input current VD2, "L" level	2	1	1	2	1	1	1	1
Rise time	1	3	3	1	1	1	1	1
Fall time	1	3	3	1	1	1	1	1
Rise delay time	1	3	3	1	1	1	1	1
Fall delay time	1	3	3	1	1	1	1	1
Output voltage, "H" level	1	2	1	1	1	1	1	1
Output voltage, "L" level	1	1	1	1	1	1	1	1
Output current, "H" level	1	2	2	1	1	1	1	1
Output current, "L" level	1	1	2	1	1	1	1	1

《SYNC separation unit》

Parameter	Switch condition		
	12	13	Other
Minimum SYNC separation level	4	2	1
Output voltage, "H" level	2	3	1
Output voltage, "L" level	2	1	1
Output current, "L" level	3	1	1
Rise time	4	2	1
Fall time	4	2	1
Rise delay time	4	2	1
Fall delay time	4	2	1

● Measurement circuit for frequency characteristics and crosstalk characteristics

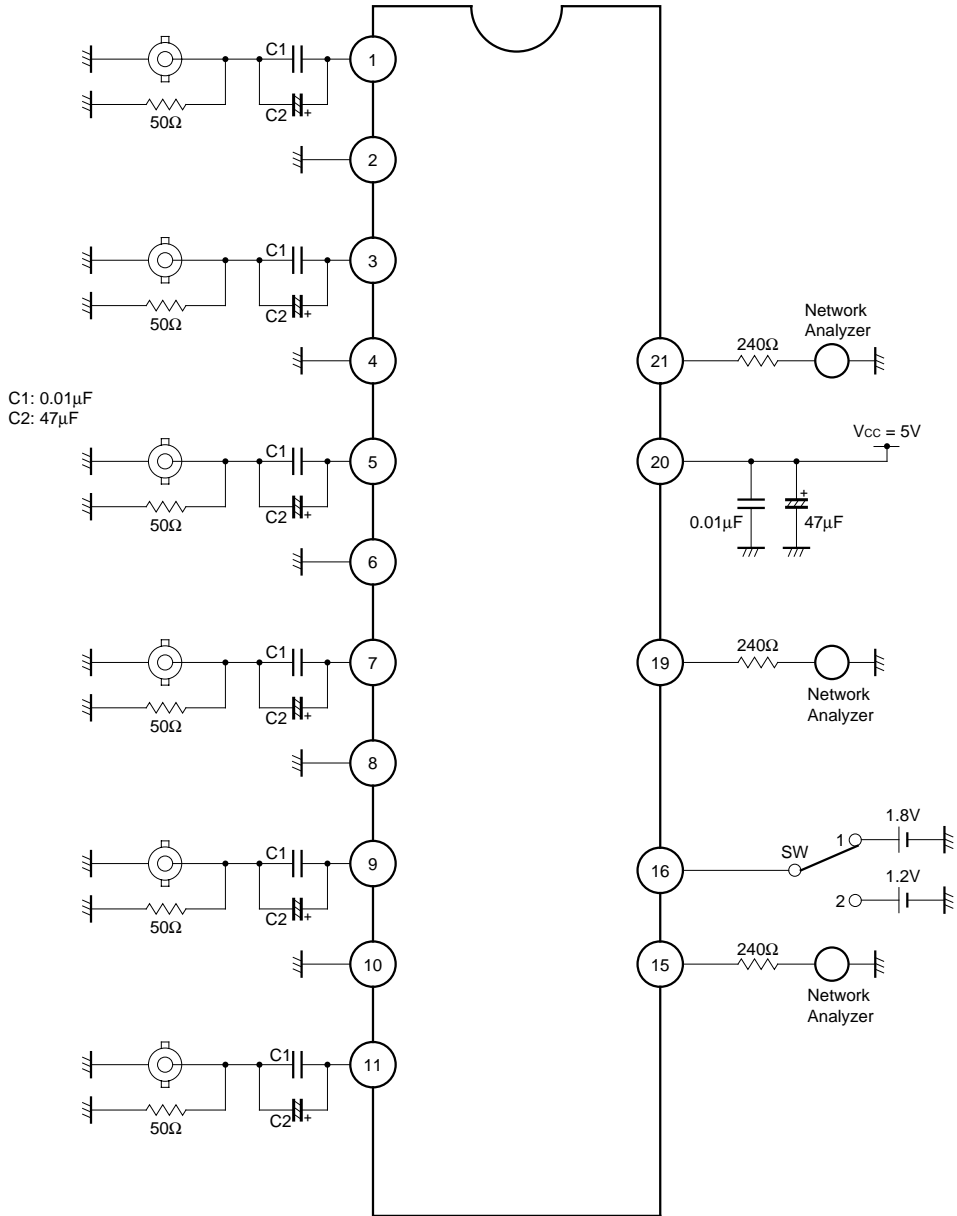

Fig. 2

●Procedure for measurement of frequency characteristics and crosstalk characteristics

(1) Frequency characteristics

Use an oscillator to input a sine wave ($V_{IN} = 1.0V_{P-P}$, $f = 1MHz / 230MHz$) to the color signal pins.

To select R1, G1 and B1: Set the switch to 1.

To select R2, G2 and B2: Set the switch to 2.

$$Gf1 = Gv (f = 1MHz) - Gv (230MHz) [dB]$$

(2) Frequency characteristic deviation

Use an oscillator to input a sine wave ($V_{IN} = 1.0V_{P-P}$, $f = 1MHz / 100MHz$) to the color signal pins.

To select R1, G1 and B1: Set the switch to 1.

To select R2, G2 and B2: Set the switch to 2.

$$Gf1 = Gv (f = 1MHz) - Gv (100MHz) [dB]$$

$$\Delta GfI = Gf (IN1) - Gf (IN2) [dB]$$

$$\Delta GfB = Gf (R1) - Gf (G1), Gf (G1) - Gf (B1),$$

$$Gf (B1) - Gf (R1) [dB]$$

(3) Input pin crosstalk (1)

Use an oscillator to input a sine wave ($V_{IN} = 1.0V_{P-P}$, $f = 10MHz$) to IN1.

Use a capacitor to connect IN2 to GND. Set the switch to 2, then select output IN2 and measure.

$$CTI1 = 20\log (V_{OUT} / V_{IN}) [dB]$$

(4) Input pin crosstalk 2

Use an oscillator to input a sine wave ($V_{IN} = 1.0V_{P-P}$, $f =$

230MHz) to IN1.

Connect IN2 to the ground through a capacitor.

Set the switch to 2, input to IN2, then measure.

$$CTI2 = 20\log (V_{OUT} / V_{IN}) [dB]$$

(5) Block crosstalk 1

Use an oscillator to input a sine wave ($V_{IN} = 1.0V_{P-P}$, $f = 10MHz$) to G1 and B1.

Connect R1 to the ground through a capacitor.

Set the switch to 1 and measure the R output.

$$CTB1R = 20\log (V_{OUTR} / V_{INB1}) [dB]$$

Similarly,

$$CTB1G = 20\log (V_{OUTG} / V_{INB1}) [dB]$$

$$CTB1B = 20\log (V_{OUTB} / V_{INR1}) [dB]$$

(6) Block crosstalk 2

Use an oscillator to input a sine wave ($V_{IN} = 1.0V_{P-P}$, $f = 230MHz$) to G1 and B1.

Connect R1 to the ground through a capacitor.

Set the switch to 1 and measure the R output.

$$CTB2R = 20\log (V_{OUTR} / V_{INB1}) [dB]$$

Similarly,

$$CTB2G = 20\log (V_{OUTG} / V_{INB1}) [dB]$$

$$CTB2B = 20\log (V_{OUTB} / V_{INR1}) [dB]$$

●Circuit operation

(1) Analog switches

Used for switching between the two sets of RGB color signals. Connect the high voltage to CTL to select IN1, or the low voltage to select IN2.

(2) Digital switches

Used for switching between the two sets of HD / VD synchronization signals. Connect the high voltage to CTL to select the HD / VD synchronization signal for IN1, or the low voltage to select the HD / VD synchronization signal for IN2.

(3) Synchronization separator

Used to output the synchronization signal after separating it from the composite signal (Sync on Green). When the HD signal is input it activates the synchronization signal detector, stopping the synchronization separator. The length of time that the synchronization separator remains stopped is set according to the constant attached to the detector wave pin of the synchronization detector.

Relationship between inputs and outputs

Input			Output		
HD	VD	Sync on Green	HD	VD	Composite Sync
—	—	○	—	—	○
○	—	○	○	—	—
—	○	○	—	○	○
○	○	○	○	○	—
○	—	—	○	—	—
—	○	—	—	○	—
○	○	—	○	○	—

● Application example

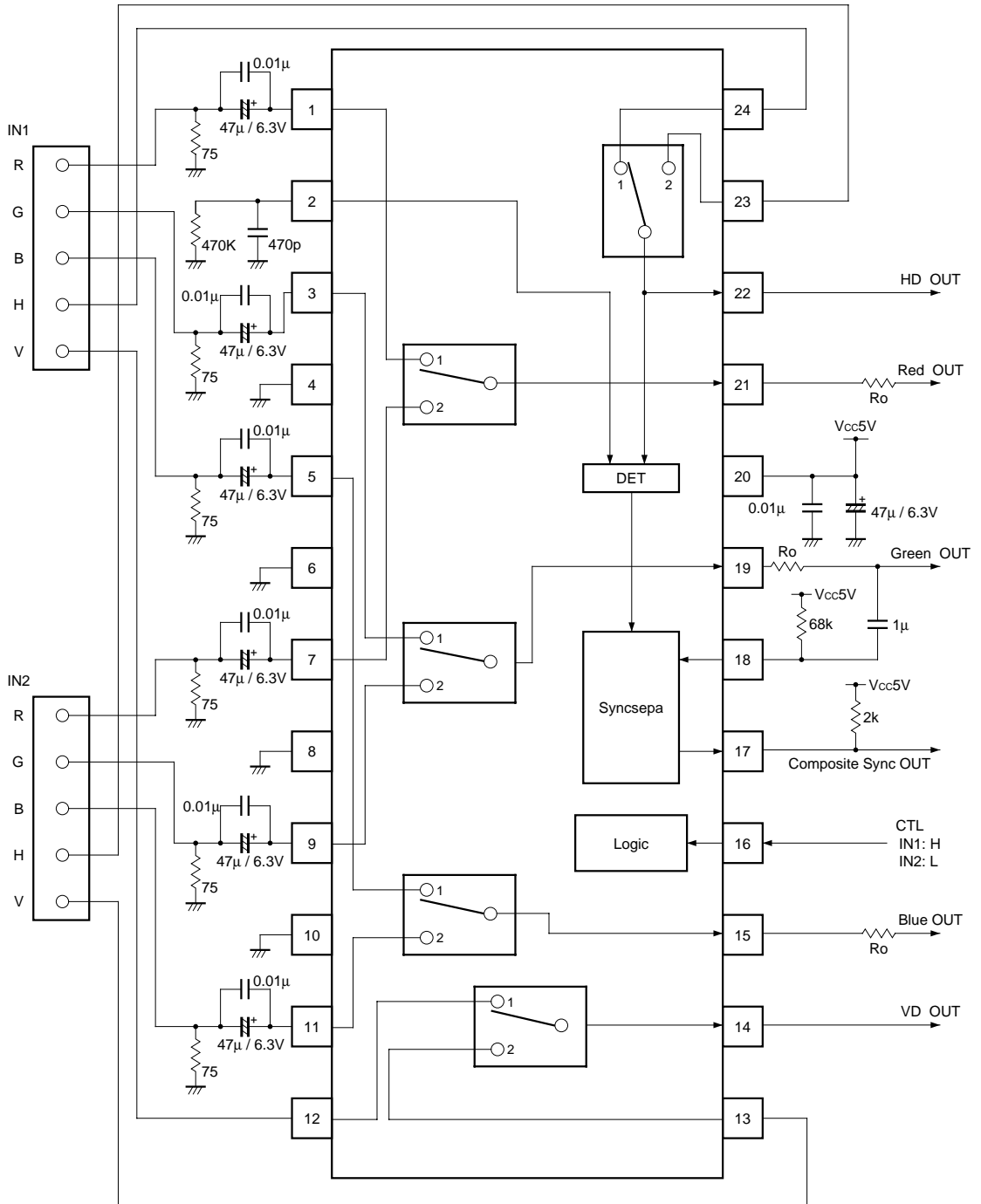

Fig. 3

●Electrical characteristic curves

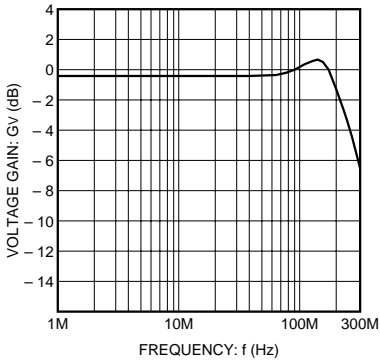

Fig. 4 Frequency characteristics

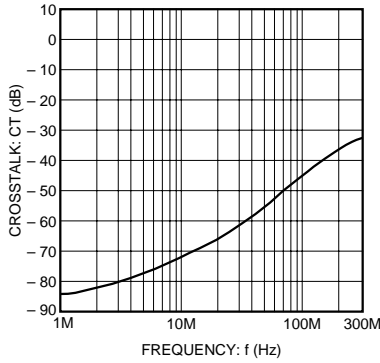

Fig. 5 Interchannel crosstalk characteristics

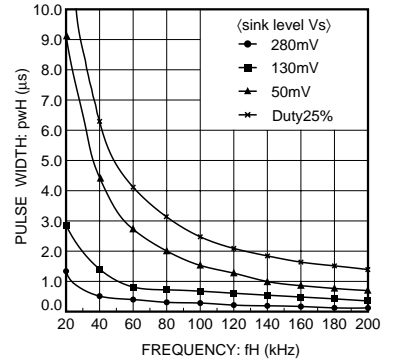

Fig. 6 Minimum SYNC separation characteristics

●Operation notes

Resistors attached to analog switch outputs
 Because analog switch frequency characteristics depend on output load capacity, set external resistance

(R_o) so that the frequency characteristics remain flat. A too-large resistance will suppress the characteristic peak.

●External dimensions (Units: mm)

