

Analog compander with vocal fader for KARAOKE

BA7726AS / BA7726AFS

The BA7726AS and BA7726AFS are analog compressors for karaoke echo systems and have internal logarithmic compression and expansion circuits, a stereo line mixer amplifier, vocal fader function, vocal detection function, microphone ALC, microphone ON / OFF switch, and output switch. When used together with the BU9252 8-bit digital delay, these ICs form a high-grade karaoke echo system with minimum components.

●Applications

Portable CD stereos with karaoke functions, VCRs, mini component stereo systems, LD players

●Features

- 1) Internal stereo line mixer amplifier, allowing selection of through output, left output, or right output.
- 2) Internal vocal elimination function, suitable for vocal faders and left and right output.
- 3) Echo level and loop ratio are DC-adjustable with the internal electronic volume control (EVR).
- 4) Internal microphone ON / OFF switch.
- 5) Vocal detection.
- 6) Internal microphone ALC function.
- 7) Internal anti-popping circuit.

●Absolute maximum ratings (Ta = 25°C)

Parameter	Symbol	Limits		Unit
Power supply voltage	Vcc	14		V
Power dissipation	Pd	BA7726AS	1250*1	mW
		BA7726AFS	850*2	
Operating temperature	Topr	- 10 ~ + 70		°C
Storage temperature	Tstg	- 55 ~ + 125		°C

*1 Reduced by 12.5mW for each increase in Ta of 1°C over 25°C.

*2 Reduced by 8.5mW for each increase in Ta of 1°C over 25°C.

●Recommended operating conditions (Ta = 25°C)

Parameter	Symbol	Min.	Typ.	Max.	Unit
Power supply voltage	Vcc	4.5	9.0	12.0	V



●Block diagram

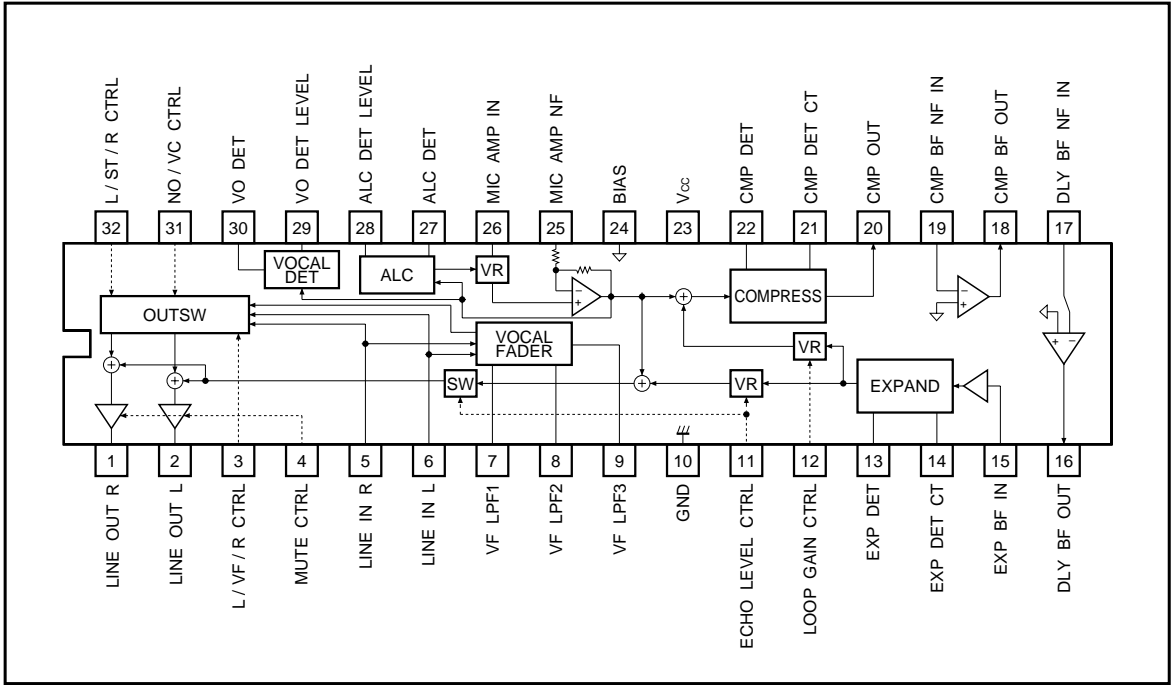

● Pin descriptions

Pin No.	Pin name	Function	Voltage	Pin type
2, 1	LINE OUT L / R	Line output (L, R)	4.5V	EF (P - P)
3	L / VF / R CTRL	Line output switching (LEFT / VOCAL FADER / RIGHT)	2.5V	*
4	MUTE CTRL	Line mute control input	—	*
6, 5	LINE IN L / R	Line input (L, R)	4.5V	100kΩ
7	VF LPF1	Vocal fader mode LPF capacitor	4.5V	23.5kΩ
8	VF LPF2	Vocal fader mode LPF capacitor	4.5V	70.5kΩ
9	VF LPF3	Vocal fader mode LPF capacitor	4.5V	EF (NPN), 15kΩ
10	GND	Ground	0.0V	—
11	ECHO LEVEL CTRL	Microphone off (ground to 0.1Vcc) / echo level adjustment (0.2Vcc to Vcc)	—	*
12	LOOP GAIN CTRL	Loop attenuation ratio setting	—	*
13	EXP DET	Expand detection wave	4.5V	50kΩ
14	EXP DET CT	Expand attack / recovery time setting Attack R = 5.6kΩ , recovery R = 85.6kΩ	—	—
15	EXP BF IN	BF input	4.5V	B (NPN)
16	DLY BF OUT	LPF BF output (EXP)	4.5V	EF (NPN)
17	DLY BF NF IN	LPF BF negative feedback input (EXP)	4.5V	B (NPN)
18	CMP BF OUT	LPF BF output (CMP)	4.5V	EF (P - P)
19	CMP BF NF IN	LPF BF negative feedback input (CMP)	4.5V	B (NPN)
20	CMP OUT	Compression output	4.5V	EF (NPN)
21	CMP DET CT	Compression attack / recover time setting Attack R = 5.6kΩ, recovery R = 85.6kΩ	—	—
22	CMP DET	Compression detection wave	4.5V	60kΩ
23	Vcc	Vcc	9.0V	—
24	BIAS	Bias and capacitor for ripple rejection	4.5V	23.5kΩ
25	MIC AMP NF	Microphone amplifier negative feedback	4.5V	2kΩ
26	MIC AMP IN	Microphone amplifier input	4.5V	100kΩ
27	ALC DET	ALC attack / recovery time setting	—	220Ω
28	ALC DET LEVEL	ALC level setting	—	B (PNP)
29	VO DET LEVEL	Microphone amplifier input detection level setting	—	B (PNP)
30	VO DET	Microphone amplifier input detection attack / recover time setting	—	1kΩ
31	NO / VC CTRL	Line output switching (NORMAL / VOCAL CUT)	—	*
32	L / ST / R CTRL	Line output switching (LEFT / STEREO / RIGHT)	2.5V	*

Note: Pin type EF: emitter follower, P-P: push-pull, B: base

For pins marked with an asterisk (*), refer to Input and output equivalent circuit.

All figures are designed values based on the measurement circuit in Fig. 1 (where Vcc = 9.0V), and are not guaranteed standards.

● Input / output circuits

L / VF / R CTRL

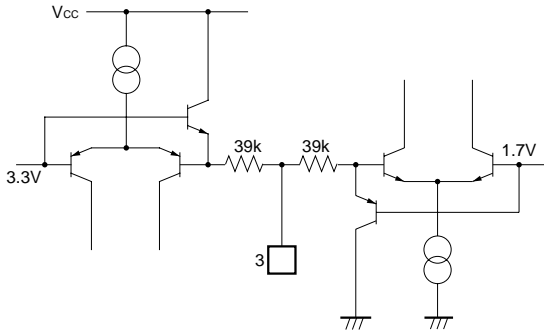

MUTE CTRL

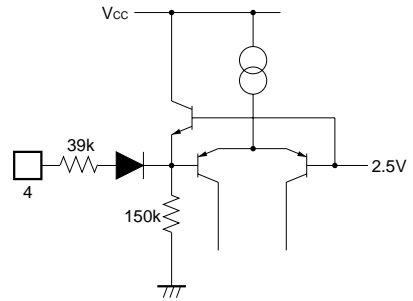

ECHO LEVEL CTRL

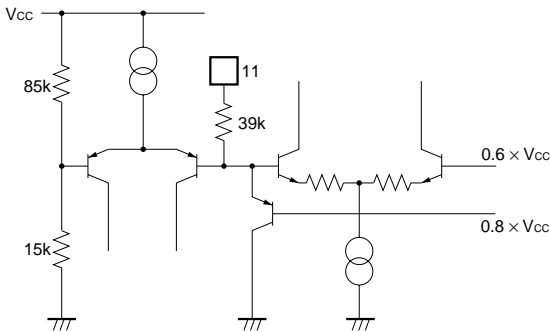

LOOP GAIN CTRL

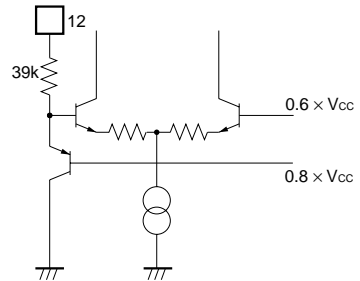

NO / VC CTRL

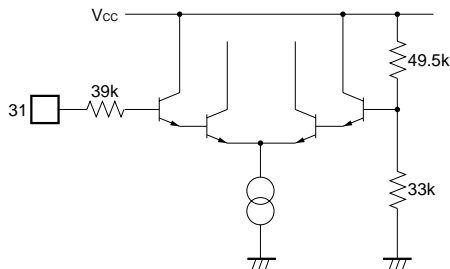

L / ST / R CTRL

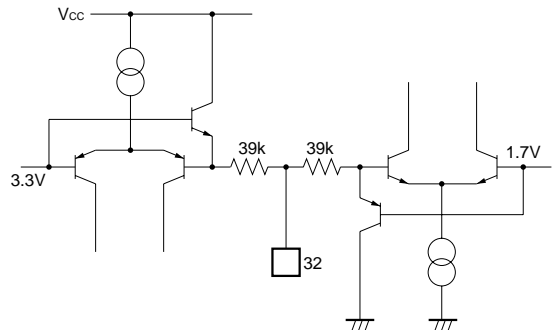

* All figures are designed values, and are not guaranteed standards.

●Electrical characteristics (unless otherwise noted, Ta = 25°C, Vcc = 9.0V)

Parameter	Symbol	Min.	Typ.	Max.	Unit	Conditions
Supply current	I _{CC}	5.5	8.4	12.7	mA	No input
(LINE THROUGH) INPUT : LINE IN, OUTPUT : LINE OUT						
Line through output level	V _{OLL}	-9.0	-8.0	-7.0	dBV	V _{IN} = -20.0dBV
Line through output distortion	THD _{LL}	—	0.026	0.2	%	V _{IN} = -20.0dBV*1 MIC OFF (V _{ECHO} = 0.1 × V _{CC})
Line through max. output level	V _{OMLL}	+7.8	+10.0	—	dBV	THD = 1%*1
Line through noise level	V _{ONLL}	—	-100	-85	dBV	No input, R _g = 1kΩ*2 MIC OFF (V _{ECHO} = 0.1 × V _{CC})
Interchannel crosstalk	CT _{LL}	—	-85	—	dBV	V _{IN} = -12dBV, R _g = 1kΩ*2 MIC OFF (V _{ECHO} = 0.1 × V _{CC})
Mute level	MT	—	-100	-85	dBV	V _{IN} = -12dBV, R _g = 1kΩ*2 MIC OFF (V _{ECHO} = 0.1 × V _{CC}) MUTE (V _{MUTE} = H)
(VOCAL CUT MODE) INPUT : LINE IN, OUTPUT : LINE OUT						
Through mode output level	V _{OLLV}	-1.0	0.0	+1.0	dBV	V _{IN} = -12dBV
Vocal suppression ratio 1	V _{OLL1}	-1.0	0.0	+1.0	dB	V _{IN} = -12dBV (single ch. in.), VOCAL FADER (V _{LSTR} = H, V _{LVFR} = OPEN, V _{NOVC} = OPEN)
Vocal suppression ratio 2	V _{OLL2}	—	-35	-28	dB	V _{IN} = -12dBV (dual ch.in.), VOCAL FADER (V _{LSTR} = H, V _{LVFR} = OPEN, V _{NOVC} = OPEN)
(MIC THROUGH) INPUT : MIC AMP IN, OUTPUT : LINE OUT						
Microphone through output level	V _{OML}	-9.9	-8.4	-6.9	dBV	V _{IN} = -38dBV
Microphone through equivalent input noise	V _{ONML}	—	-117	-102	dBV	R _g = 1kΩ*2
Microphone input crosstalk	CT _{ML}	—	-92	-77	dBV	V _{IN} = -30dBV*2 MIC OFF (V _{ECHO} = 0.1 × V _{CC})
ALC level	V _{OAML}	+5.1	+6.6	+8.1	dBV	V _{Z8} = 2.9V
(COMPRESS) INPUT : MIC AMP IN, OUTPUT : CMP BF OUT						
Compress output level	V _{OMC}	-5.5	-3.5	-1.5	dBV	V _{IN} = -38dBV
Compress characteristics	CMP	—	+5.2	—	dB	V _{IN} = -43dBV → -33dBV Output level differential
(EXPAND) INPUT : DLY BF IN, OUTPUT : LINE OUT						
Expand output level	V _{ODL}	-9.4	-7.4	—	dBV	V _{IN} = -4dBV
Expand characteristics	EXP	—	+19.4	—	dB	V _{IN} = -9dBV → +1dBV, Output level differential
Echo EVR attenuation ratio	ΔV _{ODL}	—	-50	-40	dB	V _{IN} = -4dBV and when V _{IN} = V _{odl} ECHO LEVEL = Min. (V _{ECHO} = 0.2 × V _{CC})
(Loop) INPUT : DLY BF IN, OUTPUT : CMP BF OUT						
Loop output level	V _{ODC}	-4.4	-2.4	—	dBV	V _{IN} = -4dBV
Loop EVR attenuation ratio	ΔV _{ODC}	—	-29	—	dB	V _{IN} = -4dBV and when V _{IN} = V _{odc} LOOP GAIN = Min. (V _{LOOP} = 0.2 × V _{CC})

*1 Unless otherwise noted, mode settings are as follows.

MUTE (V_{MUTE} = GND), STEREO (V_{NOVC} = GND, V_{LSTR} = OPEN, V_{LVFR} = OPEN)

ECHO LEVEL = Max. (V_{ECHO} = V_{CC}), LOOP GAIN = Max. (V_{LOOP} = V_{CC})

Signal frequency : 1kHz, *1 : B.W. = 0.4 ~ 30kHz, *2 : DIN AUDIO

*2 All parameters conform to the Measurement circuit diagram.

Parameter	Symbol	Min.	Typ.	Max.	Unit	Conditions
[Control holding voltage]						
〈MUTE CTRL (4pin)〉						
Mute holding voltage (4pin)	V _{MUTE-L}	GND	—	0.5	V	
Mute holding voltage (4pin)	V _{MUTE-H}	4.5	—	5.0	V	
〈NO / VC CTRL (31pin)〉						
Normal mode holding voltage	V _{NOVC-L}	GND	—	0.3 × V _{CC}	V	
VOCAL CUT mode holding voltage	V _{NOVC-H}	0.5 × V _{CC}	—	V _{CC}	V	
〈L / ST / R CTRL (32pin)〉						
Left mode holding voltage	V _{LSTR-L}	GND	—	0.5	V	
Stereo mode holding voltage	V _{LSTR-M}	2.2	—	2.8	V	
Right mode holding voltage	V _{LSTR-H}	4.5	—	5.0	V	
〈L / VF / R CTRL (3pin)〉						
Left mode holding voltage	V _{LVFR-L}	GND	—	0.5	V	
VOCAL FADER mode holding voltage	V _{LVFR-M}	2.2	—	2.8	V	
Right mode holding voltage	V _{LVFR-H}	4.5	—	5.0	V	
〈ECHO LEVEL CTRL (11pin)〉						
MIC OFF holding voltage	V _{ECHO-L}	GND	—	0.1 × V _{CC}	V	
MIC ON holding voltage	V _{ECHO-H}	0.2 × V _{CC}	—	V _{CC}	V	

● Measurement circuit

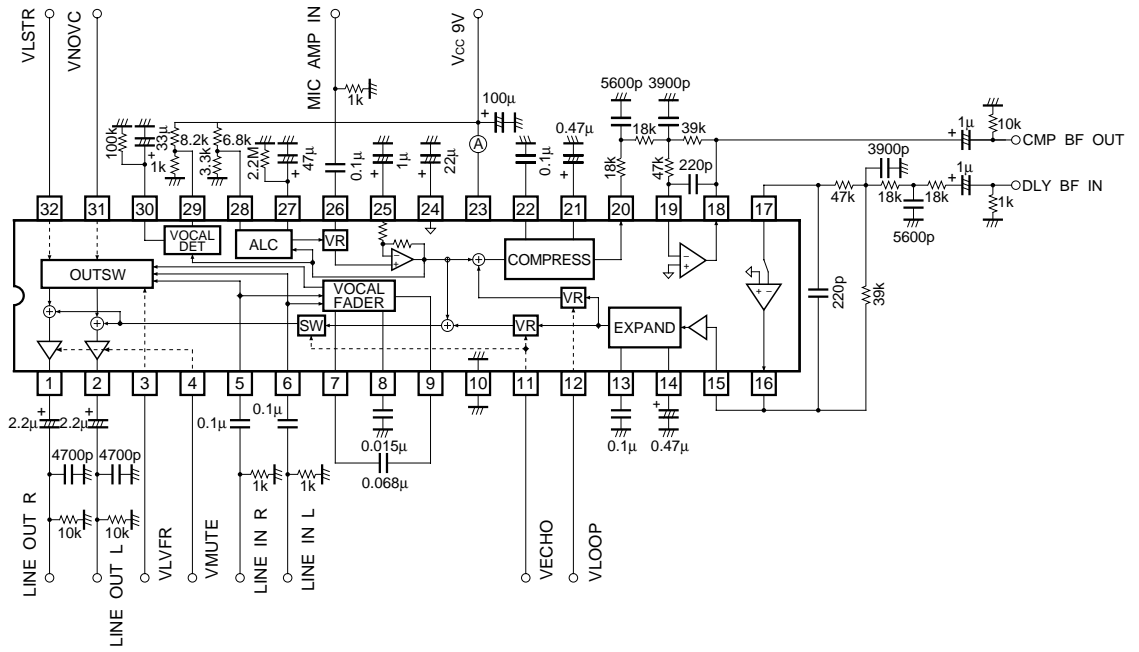

Fig. 1

● Circuit operation

(1) MUTE CTRL (pin 4)

- Controls line muting.

VMUTE (4pin)	
L	H
$\overline{\text{MUTE}}$	MUTE

(2) OUTPUT CTRL (pins 3, 31, 32)

- LINE OUT output is controlled with pins 3, 31 and 32.
(Microphone mixing is controlled with pin 11.)

1) NO / VC CTRL (pin 31)

- Used to select the NORMAL and VOCAL CUT modes.

VNOVC (31pin)	
L	H
NORMAL	VOCAL CUT

NORMAL : Normal output mode. Controlled by pin 32.

VOCAL CUT : Used to erase or attenuate vocals in multiplexed karaoke recordings and normal stereo music recordings. Controlled by pin3.

2) L / ST / R CTRL (pin 32)

- Controls LINE OUT output in the NORMAL mode.

VLSTR (32pin)		
L	M (OPEN)	H
LEFT	STEREO	RIGHT

LEFT : LINE IN L input is output to LINE OUT L / R.

STEREO : LINE IN L / R input is output to LINE OUT L / R without modification

RIGHT : LINE IN R input is output to LINE OUT L / R.

3) L / VF / R CTRL (pin 3)

- Controls LINE OUT output in the VOCAL CUT mode.

VLVFR (3pin)		
L	M (OPEN)	H
LEFT	VOCAL FADER	RIGHT

LEFT : For recordings in which the left channel is karaoke and the right channel is for vocals (with karaoke).

VOCAL FADER : Attenuates the vocals from normal stereo recordings.

RIGHT : For recordings in which the right channel is karaoke and the left channel is for vocals (with karaoke).

* When Vnovc = L, VLVFR = DON'T CARE

(3) ECHO LEVEL CTRL and MIC ON / OFF SW (pin 11)

- Between Vcc and 0.2 × Vcc: Controls echo signal mixing ratio
Between Vcc and GND : Turns microphone input sound (pin 26) to LINE OUT on and off

VECHO (11pin)	
Vcc ~ 0.2 × Vcc	0.1 × Vcc ~ GND
MIC ON and ECHO LEVEL CTRL	MIC OFF

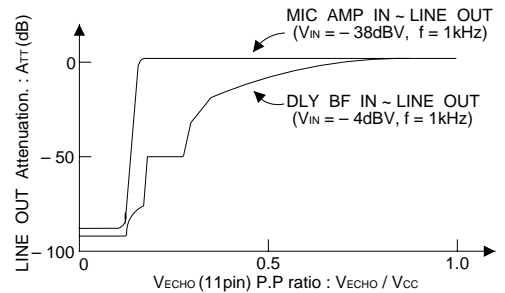

Fig. 2 LINE OUTattenuation ratio vs. Vecho (11pin) partial pressure ratio

* These figures are for standard samples and are not guaranteed standards.

(4) LOOP GAIN CTRL (pin 12)

- Adjusts the loop gain (pins 17 and 18).

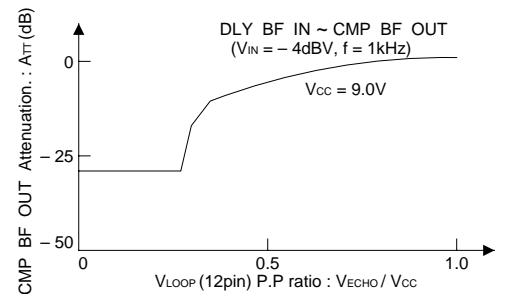

Fig. 3 CMP BF OUT attenuation ratio vs. Vloop (pin 12) partial pressure ratio

* These figures are for standard samples and are not guaranteed standards.

(5) LPF

- Use the internal operational amplifier and an attached capacitor and resistor to configure a tertiary LPF for anti-aliasing and smoothing.

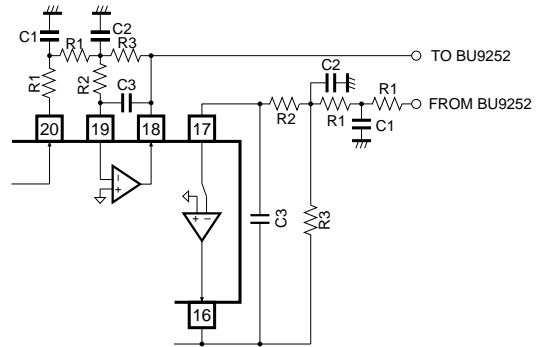

Fig. 4 LPF

LPF constant examples (V_{CC} = 9.0V)

Cutoff frequency	LPF constant						Pass band gain
	R ₁	R ₂	R ₃	C ₁	C ₂	C ₃	
2kHz	22kΩ	56kΩ	47kΩ	6800pF	4700pF	270pF	0.6dB
3kHz	18kΩ	47kΩ	39kΩ	5600pF	3900pF	220pF	0.7dB
4kHz	15kΩ	39kΩ	33kΩ	4700pF	3300pF	180pF	0.8dB

* CMP OUT (pin 20) output is positively correlated with V_{CC}. When V_{CC} is a voltage other than 9.0V, set the pass band gain so that maximum CMP side LPF output (input to BU9252) is 5Vp-p. Make sure that the EXP side LPF constant does not exceed the load drive capability (minimum = 0.3mA, typical 0.5mA).

(6) Vocal fader function

- After the synchronous component of the left and right channels is eliminated, LPF output is added to the signal, which is then output (see figure below). The vocal component is difficult to remove from certain types of sources.

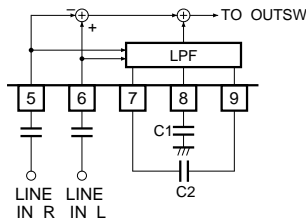

Fig. 5 Vocal fader block

LPF constant examples

Cutoff frequency	LPF constant	
	C ₁	C ₂
100Hz	0.022μF	0.1μF
150Hz	0.015μF	0.068μF
200Hz	0.01μF	0.047μF

* C₁ and C₂ are only necessary when using the vocal fader function.

(7) ALC level

- When V_{CC} is 9.0V, ALC level can be set roughly

between -4dBV and +9dBV, and is determined by the voltage impressed on pin 28 (V₂₈, set with resistive division between V_{CC} and the ground). ALC level is calculated with the following equation, although slight error occurs as V₂₈ approaches V_{CC}.

$$V_{OAML} \cong \frac{1}{2 \times \sqrt{2}} \times (V_{CC} - V_{28}) [V_{rms}],$$

$$1.0 \cong V_{28} \cong 0.85 \times (V_{CC} - 1.0), \text{ at LINE OUT}$$

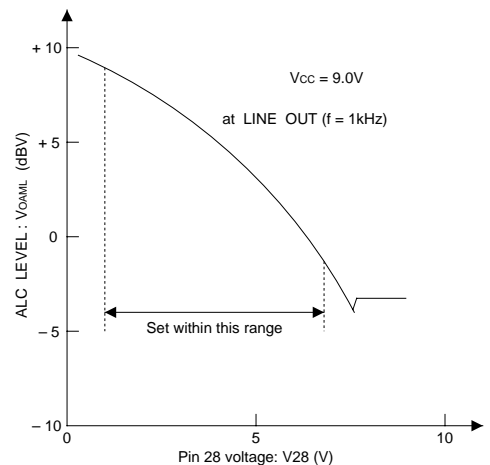

Fig. 6 ALC level vs. pin 28 voltage

* These figures are for standard samples and

(8) Microphone input detection function

- This function detects the signal input to MIC AMP IN (pin 26) and outputs it to pin 30.

	Pin 30 output
No signal input to MIC AMP IN (pin 26)	GND
Signal input to MIC AMP IN (pin 26)	V _{CC} - 1.0V

- The detection level is determined by the voltage impressed on pin 29 (V₂₉, set with resistive division between V_{CC} and the ground) and is calculated with the following equation, although slight error occurs as V₂₈ approaches ground.

$$V_{ODET} \approx 0.03 \times \left(\frac{1}{2 \times \sqrt{2}} \times V_{29} \right) [V_{rms}],$$

$$0.5 \leq V_{29} \leq 0.85 \times (V_{CC} - 1.0), \text{ at MIC AMP IN}$$

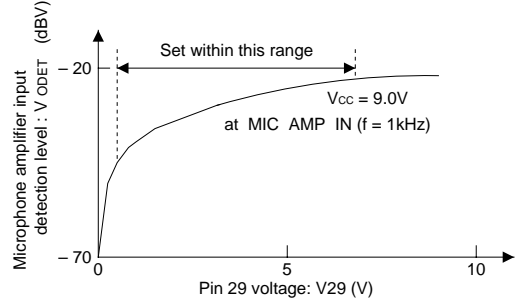
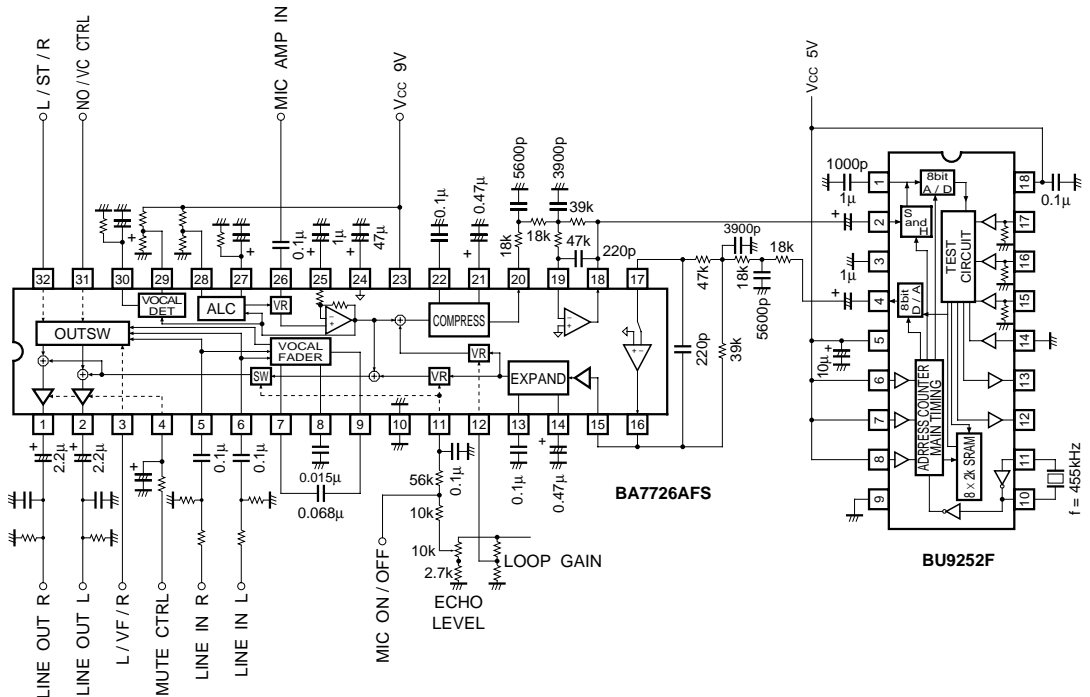

Fig. 7 Microphone amplifier input detection level vs. pin 29 voltage

* These are figures for standard samples and are not guaranteed standards.

● Application example



●Operation notes

(1) LINE OUT (pins 1 and 2) signal processing

- Be sure to attach a capacitor for phase correction to the LINE OUT pins.

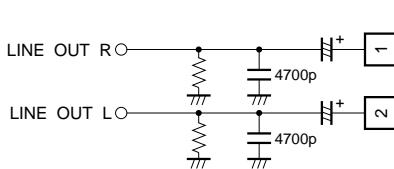

Fig. 9

(2) Setting the loop gain

- Set the LPF constant and pin 12 control voltage so that the loop gain (1st echo wave / 2nd echo wave) does not exceed 1. Be particularly careful of peaking near the LPF cutoff point.

(3) ALC function and microphone amplifier input detection function

- Refer to items 7 and 8 in "Circuit description." When these functions are not used, be sure to ground pins 27 and 28 (the ALC function) and pins 29 and 30 (microphone amplifier input detection function).

●External dimensions (Units: mm)

