

CTL recording / playback amplifier for VHS VCRs

BA8400FV

The BA8400FV is a CTL recording / playback amplifier developed for VHS VCRs. The playback amplifier has an AGC circuit that can handle large input signal fluctuations, and a recording / playback switching circuit is provided to allow high-speed switching.

●Applications

VHS-format VCRs

●Features

- 1) Can be operated off low power supply voltage (2.7V to 3.5V).
- 2) Playback amplifier with AGC.
- 3) Fast switching between recording and playback.

●Block diagram

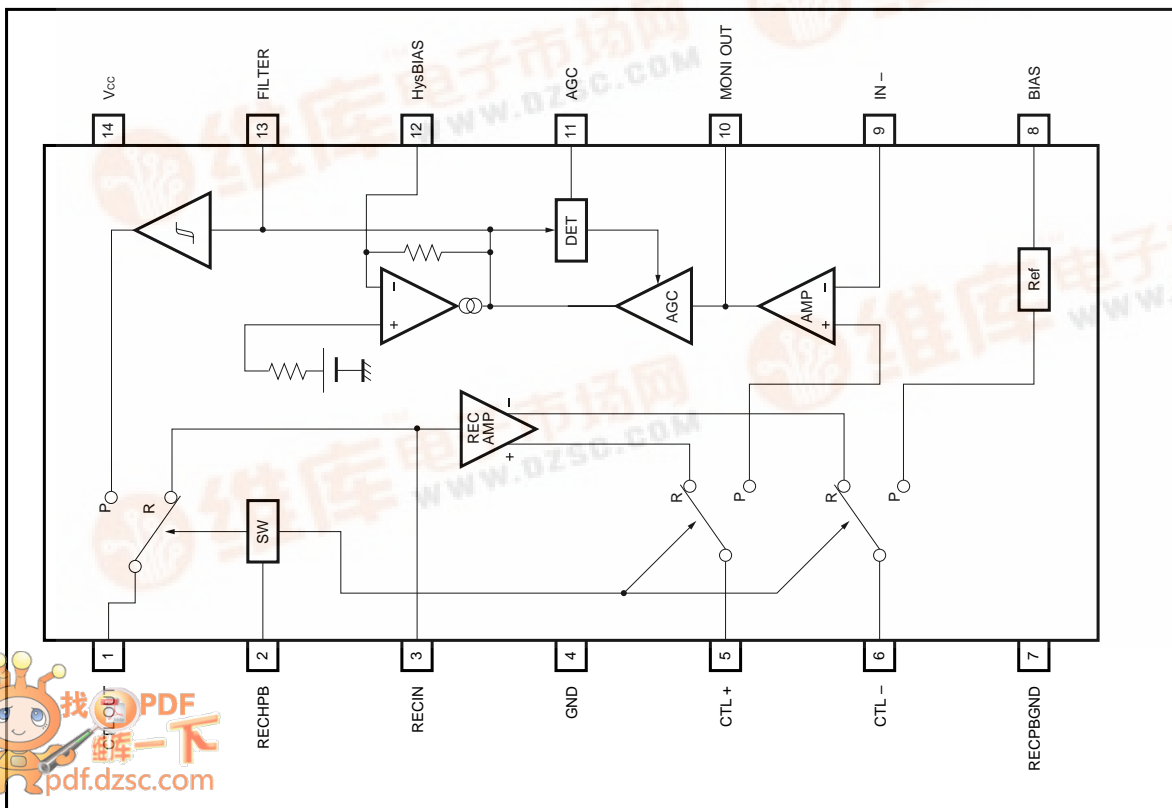

●Pin descriptions

Pin No.	Pin name	Function
1	CTL OUT (CTL pulse output)	CTL pulse output. High output level approx. $V_{cc} - 0.05V$, $I_o = +0.5mA$ Low output level approx. $0.05V$, $I_o = -0.5mA$
2	RECHPB (record / play switch)	Switch input pin for the record / playback amplifiers. High input: REC mode Low input: PB mode Threshold voltage: approx. $1 / 2V_{cc}$
3	RECIN (REC CTL pulse input)	CTL pulse input pin for recording. Threshold voltage: approx. $1 / 2V_{cc}$
4	GND	Power, REC / PB SW, CTL output buffer ground pin.
5	CTL + (CTL head "+" input)	When recording: CTL head positive-side recording current. When playing: input pin for the playback CTL pulse.
6	CTL - (CTL head "-" input)	When recording: CTL head negative-side recording current. When playing: bias pin for the playback CTL pulse input.
7	RECPBGND	Ground pin for the REC and playback amplifiers.
8	BIAS (bias)	Bias pin for the playback amplifier. Bias voltage: $V_{IB8} = 0.15V_{cc} + 1.3V$ (approx.)
9	IN - (playback amplifier input)	Feedback input pin for the playback amplifier.
10	MONIOUT (playback amplifier output)	Playback amplifier output monitor pin. Output dynamic range is the DC level $\pm V_f$.
11	AGC (AGC time constant)	Set the time constant after considering the transient response of the playback mode switching. AGC detect level $V_{detAGC} = 0.47V_{cc}$ [V] (approx.) Playback amplifier output amplitude $V_{AGC} = 2 \times (V_{detAGC} - HysV_{cent})$ [V_{P-P}]
12	HysBIAS (hysteresis amplifier center level)	Connection pin for the bypass capacitor for the hysteresis amplifier center level.
13	FILTER (high-frequency noise filter)	Pin for connection of high-frequency noise filter for AGC amplifier output for playback CTL pulse. Also, input pin for the hysteresis amplifier. Hysteresis amplifier center voltage $HysV_{cent} = 0.27V_{cc}$ [V] approx. High-side hysteresis width $\Delta HysV_H = 0.367V_{cc} - HysV_{cent}$ [V] Low-side hysteresis width $\Delta HysV_L = 0.173V_{cc} - HysV_{cent}$ [V]
14	V_{cc}	Connect a decoupling capacitor close to the pin.

●Absolute maximum ratings ($T_a = 25^\circ C$)

Parameter	Symbol	Limits	Unit
Power supply voltage	V_{cc}	8.0	V
Power dissipation	P_d	450*	mW
Operating temperature	T_{opr}	-25 ~ +75	$^\circ C$
Storage temperature	T_{stg}	-55 ~ +125	$^\circ C$

* Reduced by 4.5mW for each increase in T_a of $1^\circ C$ over $25^\circ C$.●Recommended operating conditions ($T_a = 25^\circ C$)

Parameter	Symbol	Limits	Unit
Applied voltage	V_{cc}	2.7 ~ 3.5	V

○Not designed for radiation resistance.

●Input / output circuits

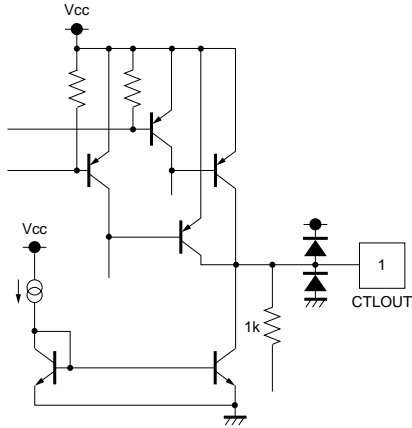

Fig.1

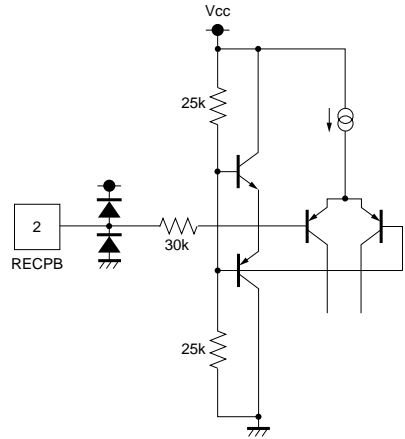

Fig.2

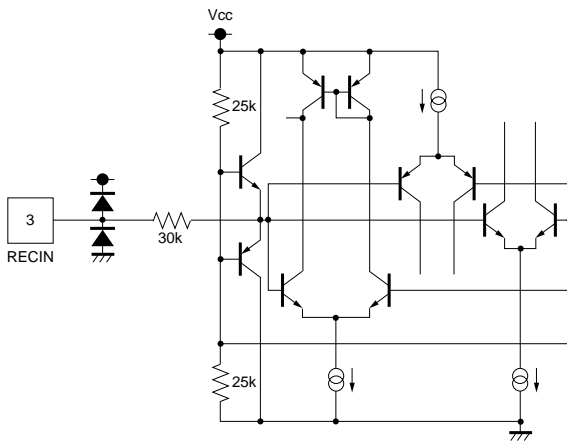

Fig.3

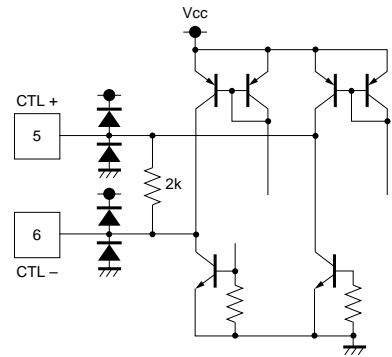

Fig.4

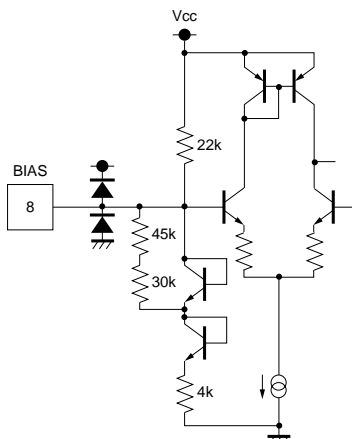

Fig.5

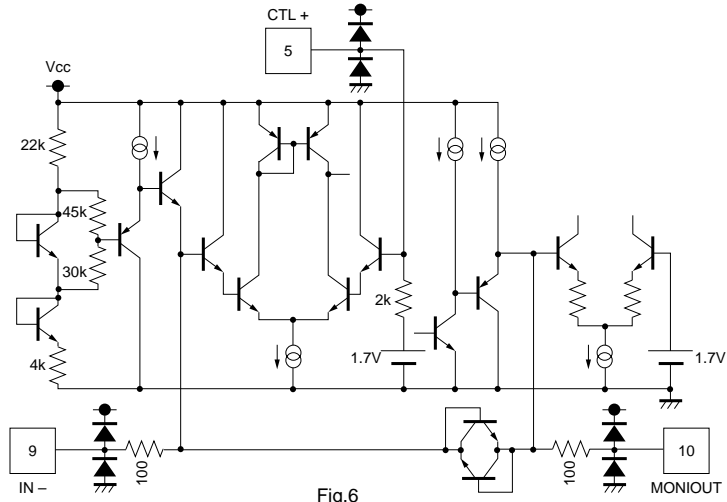

Fig.6

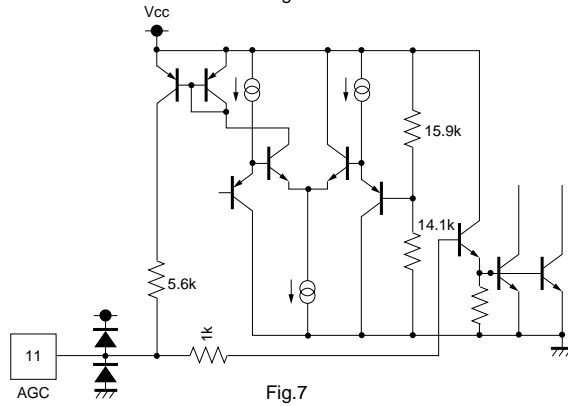

Fig.7

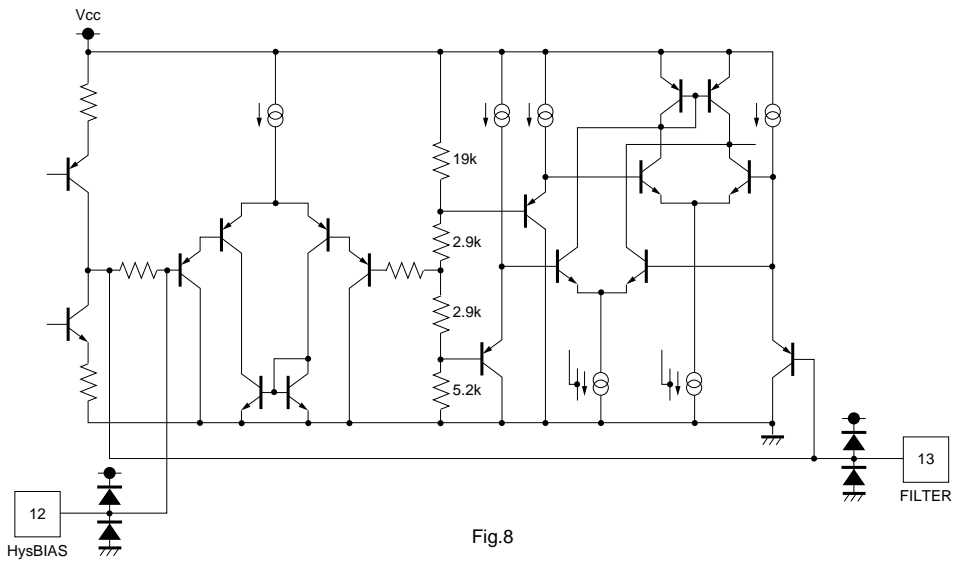

Fig.8

●Electrical characteristics (unless otherwise noted, Ta = 25°C and Vcc = 3V)

Parameter	Symbol	Min.	Typ.	Max.	Unit	Conditions
Circuit current	I _{CC}	—	3.5	7.0	mA	No signal, CTLOUT: High
〈AGC amplifier〉						
AGC amplifier gain	GV _{agc}	2.5	4.5	6.5	dB	—
Input bias voltage	V _{IB8}	1.35	1.7	2.05	V	—
Pin 5 input resistance	Z _{IN5}	1.6	2.0	2.4	kΩ	—
AGC control sensitivity	ΔAGC / V	- 2	0	+ 2	dB	V _{IN} = 0.15→1.0V _{P-P}
Output amplitude	V _{AGC}	0.88	1.1	1.32	V _{P-P}	f = 300Hz, V _{IN} = 300mV _{P-P}
〈Hysteresis amplifier〉						
Hysteresis width	ΔHysV	± 250	± 290	± 330	mV	—
CTLOUT output high level voltage	VOHP	2.0	2.8	—	V	I _o = - 0.5mA
CTLOUT output low level voltage	VOLP	—	0.2	1.0	V	I _o = + 0.5mA
〈REC amplifier〉						
Recording current	I _{rec}	± 1.3	± 2.5	± 3.7	mA	R _o = 400 W
Max. output high level voltage	VOHR	2.0	2.8	—	V	I _o = - 0.5mA
Max. output low level voltage	VOLR	—	0.2	1.0	V	I _o = + 0.5mA
Threshold voltage	V _{th3}	1.0	1.5	2.0	V	—
Input resistance	Z _{IN3}	24	30	36	kΩ	—
〈REC / PB switch〉						
Threshold voltage	V _{th2}	1.0	1.5	2.0	V	—
REC to PB switching time	TR - P	—	—	100	ms	*See note below

* Note: The switching time from REC to PB is the time until CTLOUT is output.

● Measurement circuit

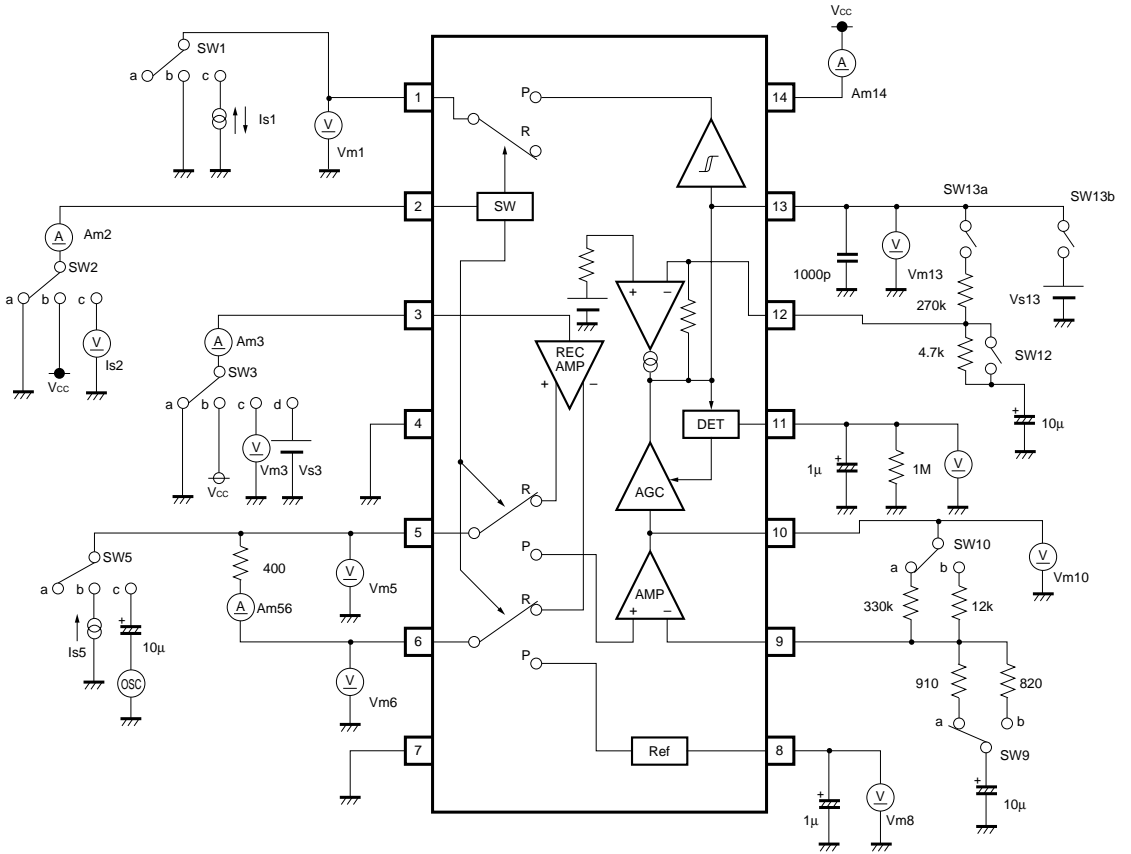

Fig.9

● Measurement conditions (unless otherwise noted, $T_a = 25^\circ\text{C}$ and $V_{CC} = 3\text{V}$)

Parameter	Symbol	Monitor	Switch position									Notes
			SW 1	SW 2	SW 3	SW 5	SW 9	SW 10	SW 12	SW 13a	SW 13b	
Circuit current	I _{CC}	Am14	a	a	a	a	a	a	ON	OFF	OFF	—
〈AGC amplifier〉												
AGC amplifier gain	GV _{AGC}	Vm13	a	a	a	c	b	b	OFF	ON	OFF	*1. $f = 300\text{Hz}$, $V_{IN} = 50\text{mV}_{P-P}$
Input bias voltage	VIB8	Vm8	a	a	a	a	a	a	ON	OFF	OFF	—
Pin 5 input resistance	Z _{IN5}	Vm5	a	b	b	b	a	a	ON	OFF	OFF	*2.
AGC control sensitivity	$\Delta\text{AGC} / V$	13pin	a	a	a	c	a	b	ON	OFF	OFF	*3. $f = 300\text{Hz}$, $V_{IN} = 0.15 / 1.0\text{V}_{P-P}$
Output amplitude	VAGC	13pin	a	a	a	c	a	b	ON	OFF	OFF	*4. $f = 300\text{Hz}$, $V_{IN} = 300\text{mV}_{P-P}$
〈Hysteresis amplifier〉												
Hysteresis width	ΔHysV	Vm1	a	a	a	a	a	a	ON	OFF	b	*5.
CTLOUT output voltage H	VOHP	Vm1	c	a	a	a	a	a	ON	OFF	b	$I_o = -0.5\text{mA}$, $V_{S13} = 1.5\text{V}$
CTLOUT output voltage L	VOLP	Vm1	c	a	a	a	a	a	ON	OFF	b	$I_o = +0.5\text{mA}$, $V_{S13} = 0\text{V}$
〈REC amplifier〉												
Recording current 5	I _{rec5}	Am56	a	b	b	a	a	a	ON	OFF	OFF	—
Recording current 6	I _{rec6}	Am56	a	b	a	a	a	a	ON	OFF	OFF	—
Max. output voltage "H"	VOHR	Vm1	c	b	b	a	a	a	ON	OFF	OFF	$I_o = -0.5\text{mA}$
Max. output voltage "L"	VOLR	Vm1	c	b	a	a	a	a	ON	OFF	OFF	$I_o = +0.5\text{mA}$
Input threshold voltage	V _{th3}	Vm3	a	b	c	a	a	a	ON	OFF	OFF	—
Input resistance	Z _{IN3}	Vm3	a	b	d	a	a	a	ON	OFF	OFF	*6.
〈REC / PB switch〉												
Threshold voltage	V _{th2}	Vm2	a	c	a	a	a	a	ON	OFF	OFF	—
REC to PB switching time	TR-P	1pin	a	ba	a	c	a	a	ON	OFF	OFF	*6.

Measurement method

- *1 Input a sine wave of $f = 300\text{Hz}$ to pin 5, and measure the output amplitudes on pins 10 and 13 (V_{o10} and V_{o13}).
The AGC gain is given by: $G_{VAGC} = 20\log(V_{o13} / V_{o10})$ [dB].
- *2 Measure the output voltages V_{o0} and $V_{o.5}$ on pin 5 when currents of $I_{s5} = 0$, and $I_{s5} = 0.5\text{mA}$ are applied.
The input resistance is given by: $Z_{IN5} = \{0.0005 / (V_{o.5} V_{o0})\}^{-1}$ [Ω]
- *3 Input a sine wave of $f = 300\text{Hz}$ to pin 5. Adjust the input level until the output amplitude on pin 10 is 0.15V_{P-P} and 1.0V_{P-P} , and measure the corresponding output amplitudes on pin 13 ($V_{o0.15}$ and $V_{o1.0}$).
The AGC control sensitivity is given by: $\Delta\text{AGC} / V = 20\log(V_{o1.0} / V_{o0.15})$ [dB].
- *4 Input a sine wave of $f = 300\text{Hz}$ to pin 5. Adjust the input level until the output amplitude on pin 10 is 300mV_{P-P} .
Measure the output amplitude on pin 13.
- *5 With pin 13 floating, measure the output voltage V_{ocent} .
Increase V_{S13} from 0V , and record V_{INH} as the V_{S13} voltage when the pin 1 output exceeds 2.8V .
Decrease V_{S13} from 1.5V , and record V_{INL} as the V_{S13} voltage when the pin 1 output goes below 0.2V .
High-side hysteresis width $\Delta\text{HysVH} = V_{INH} V_{ocent}$ [V_{P-P}]
Low-side hysteresis width $\Delta\text{HysVL} = V_{INL} V_{ocent}$ [V_{P-P}]
- *6 Measure the currents $I_{IN2.7}$ and $I_{IN3.0}$ on pin 3 when voltages V_{S3} of 2.7V and 3.0V respectively are applied.
The input resistance is given by: $Z_{IN3} = 0.3 / (I_{IN3.0} I_{IN2.7})$ [Ω]
- *7 Input a square wave of 300Hz , $V_{IN} = 20\text{mV}_{P-P}$ to pin 5, and measure the time that it takes CTLOUT to be output after pin 2 goes from V_{CC} to 0V .

●External dimensions (Units: mm)

