



BCM3250 PRODUCT Brief



BCM3250 QAMLINK® ADVANCED SET-TOP BOX SINGLE-CHIP FRONT-END

FEATURES

- **Two complete QAMLink variable symbol rate receivers (in-band video and DOCSIS/EuroDOCSIS IP data receive channels)**
 - Dual 10-bit A/D converters with input AGC amplifiers
 - Dual 1-7 Mbaud 256-QAM receivers
 - Dual ITU-T J.83 Annex A/B/C compatible FEC decoders
- **QPSK out-of-band receiver**
 - 100 – 200 MHz LO with AGC and 6-bit A/D converter
 - DigiCipher II®/DVB/DAVIC FEC decoder
- **Upstream QPSK/16-QAM transmitter**
 - 0 – 65 MHz direct RF output
 - Programmable Starvue II/DOCSIS/EuroDOCSIS/DVB/DAVIC FEC encoder
 - 10-bit D/A converter with output power control interfaces
- **DOCSIS/EuroDOCSIS media access controller (MAC)**
 - DOCSIS/EuroDOCSIS version 1.1 based
 - Extensions for fragmentation and concatenation
 - Support for enhanced Quality of Service (QoS) for Voice over IP (VoIP) applications
- **DAVIC media access controller (MAC)**
 - DAVIC 1.2/1.5 compliant
 - Support for 1.5 Mbps and 3 Mbps on both upstream and downstream
 - Parsing, CRC, and ATM cell extraction
 - Hardware SAR engine
- **Both processor interface and PCI 2.2**
- **Direct interface to VoIP DSP**

SUMMARY OF BENEFITS

- **Represents a complete solution for interactive set-top box front-end, including cable modem functions.**
 - Universal front-end supports the ITU-T J.83 Annex A/B/C as well as OpenCable, DOCSIS/EuroDOCSIS and DVB/DAVIC.
 - DOCSIS/EuroDOCSIS 1.1-based media access controller (MAC) supports Voice over IP and high-speed Internet access capability.
 - DAVIC 1.2/1.5 MAC supports conditional access systems and lower data rate services.
 - BCM3250, together with BCM7020/BCM7030 Video Decoder and Graphics Engine, provide a two-chipset solution for OpenCable applications.
- **Includes second in-band channel pass through for picture-in-picture functionality and multiple camera angles.**
- **Integration of all analog functions leads to lower system cost and improved performance.**
- **Single upstream transmitter is shared between modem and upstream interactive video commands, eliminating the need for a second upstream channel.**
- **Integrated peripheral control unit supports required set-top box peripherals without additional external devices.**

Interactive Set-Top Box System Block Diagram

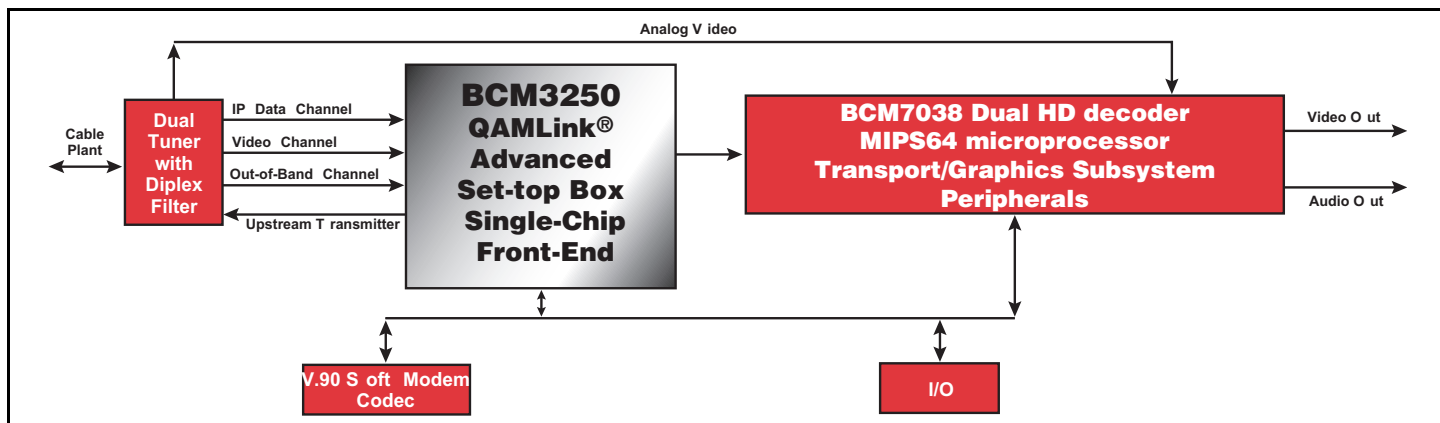

OVERVIEW

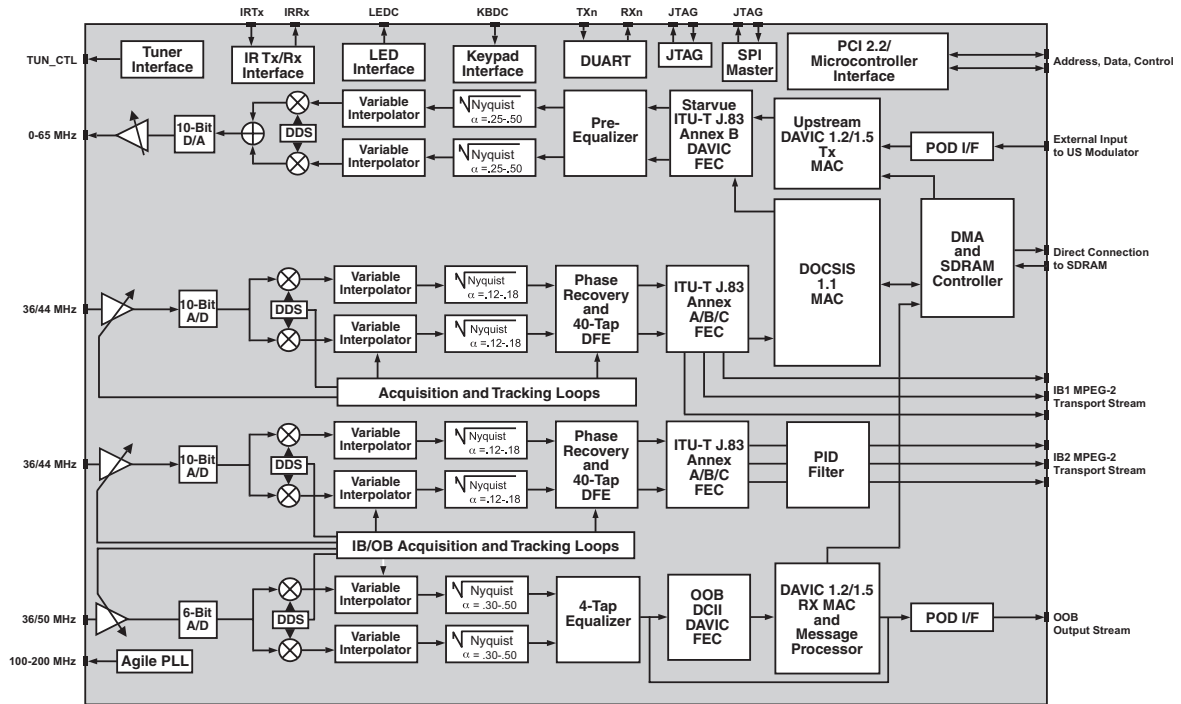

The Broadcom **BCM3250** combines dual 256-QAM receivers, a 4/16-QAM burst transmitter, an out-of-band QPSK receiver, a DOCSIS/EuroDOCSIS 1.1 based MAC, and a DAVIC 1.2/1.5 compliant MAC integrated into a single chip. The **BCM3250** is the world's first complete front-end solution with an integrated DOCSIS/EuroDOCSIS 1.1 MAC to address the next generation of OpenCable/interactive set-top boxes. Quality of Service (QoS) and fragmentation are supported for additional applications, such as telephony and high-speed Internet access.

The dual receivers in the **BCM3250** directly sample a 36–44 MHz carrier frequency with a 10-bit A/D converter, which is preceded by a programmable gain amplifier (PGA). Two distinct forward error correction (FEC) methods are supported in each receiver. The first standard, ITU-T J.83 Annex A/C, is also referred to as the DVB or DAVIC standard. The second, ITU-T J.83 Annex B, is variously known as DigiCipher II® and SCTE DVS-031.

The out-of-band (OOB) receiver in the **BCM3250** contains a frequency agile oscillator that can down convert any channel in the 70–130 MHz frequency range to a SAW centered IF. The desired channel is then sub-sampled by a 6-bit A/D converter at a rate that is more than four times the symbol rate. OOB data can be passed through or terminated by the DAVIC MAC or message processor.

On the upstream channel, the **BCM3250** provides complete Starvue II, Annex B, and DAVIC compatible 4/16-QAM upstream burst FEC

encoder and modulator functionality. In the final stage, an on-chip 10-bit DAC converts the signal to an analog waveform with programmable output power levels.

The DOCSIS/EuroDOCSIS 1.1 MAC includes baseline privacy encryption and decryption, transmission convergence sublayer support, a TDM/TDMA framer and a scatter/gather DMA interface. The MAC in the **BCM3250** also includes fragmentation, concatenation, and multiple SIDs, enabling full support for Quality of Service applications such as Voice over IP.

The DAVIC 1.2/1.5 MAC enables the **BCM3250** to operate in DAVIC-centric conditional access systems. It supports Extended Super Frame (ESF) parsing on the downstream and upstream timing/synchronization. Hardware also performs data filtering and SAR functions.

The **BCM3250** also provides a peripheral control unit consisting of a keypad controller, LED controller, IR receiver and transmitter controller. In addition, dual UARTs, a generic I/O port controller, an interrupt controller, and an RF tuner controller are included.

The high level of integration of the **BCM3250** provides the lowest system cost for the next generation of interactive set-top boxes. The **BCM3250**, along with the BCM7038, provides a complete interactive set-top box solution with advanced graphics capabilities.

Broadcom®, the pulse logo, and Connecting everything® are trademarks of Broadcom Corporation and/or its subsidiaries in the United States and certain other countries. All other trademarks mentioned are the property of their respective owners.

Connecting
everything®



BROADCOM CORPORATION
16215 Alton Parkway, P.O. Box 57013
Irvine, California 92619-7013

© 2003 by BROADCOM CORPORATION. All rights reserved.

Phone: 949-450-8700
Fax: 949-450-8710
E-mail: info@broadcom.com
Web: www.broadcom.com