

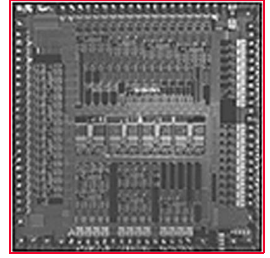

# BCM3416 PRODUCT Brief



## ADVANCED DIGITAL CABLE TUNER

### FEATURES

- Supports 64 and 256 QAM
- Input frequency range of 50 MHz through 860 MHz \*
- IF output range of 36 MHz through 44 MHz
- High linearity across entire frequency range
- Differential signals for high noise immunity
- Eliminates need for image reject mixer
- Highly integrated and cost-effective
  - Minimal BOM with reference designs available
  - IF AGC and frequency synthesizers included
  - Standard logic CMOS with single 3.3V supply
  - 48-pin TQFP

\* = For use only in applications where the input frequency to the diplexer is less than 1000 MHz.

### SUMMARY OF BENEFITS

- Narrowband first IF eliminates processing of unnecessary channels
- DOCSIS and EuroDOCSIS 1.0/1.1/2.0 compliant
- Minimal in-house RF expertise required
- Superior alternative to can tuners
  - High quality and reliability (no hand tweaking)
  - Enables lower profile and smaller designs
  - Simplified manufacturing flow
  - Lower BOM cost
- Applications
  - Cable modems
  - Cable set-top boxes

### Tuner Application Example (Cable Modem)

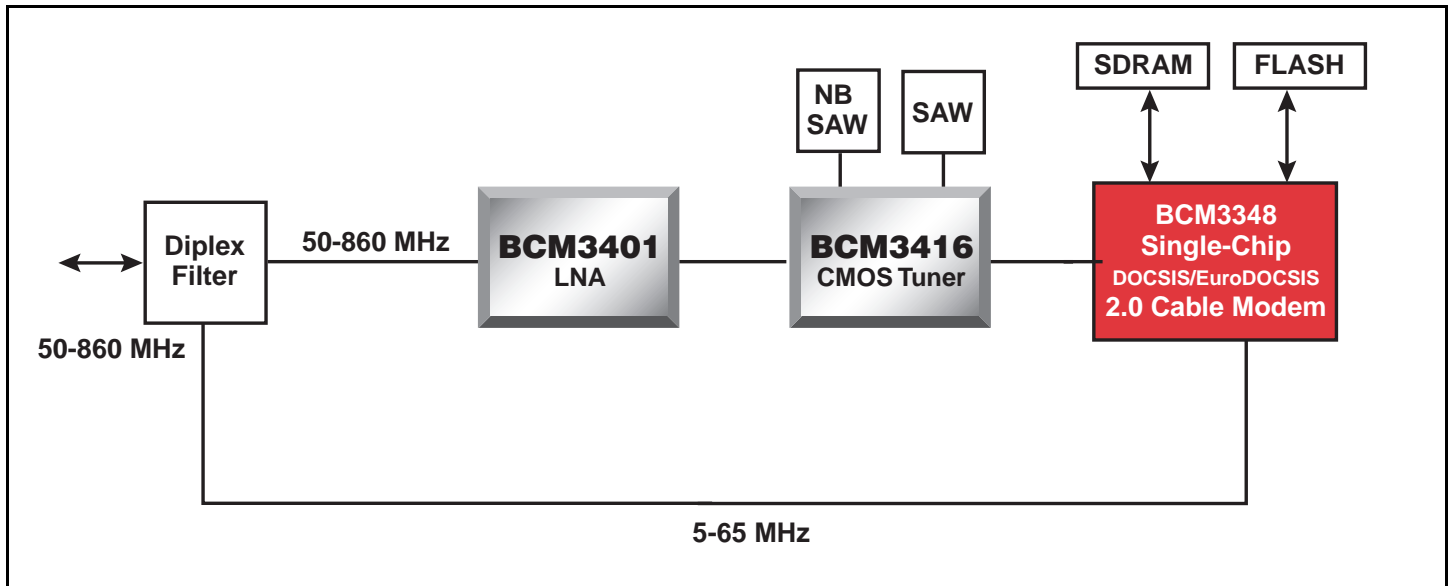

## OVERVIEW

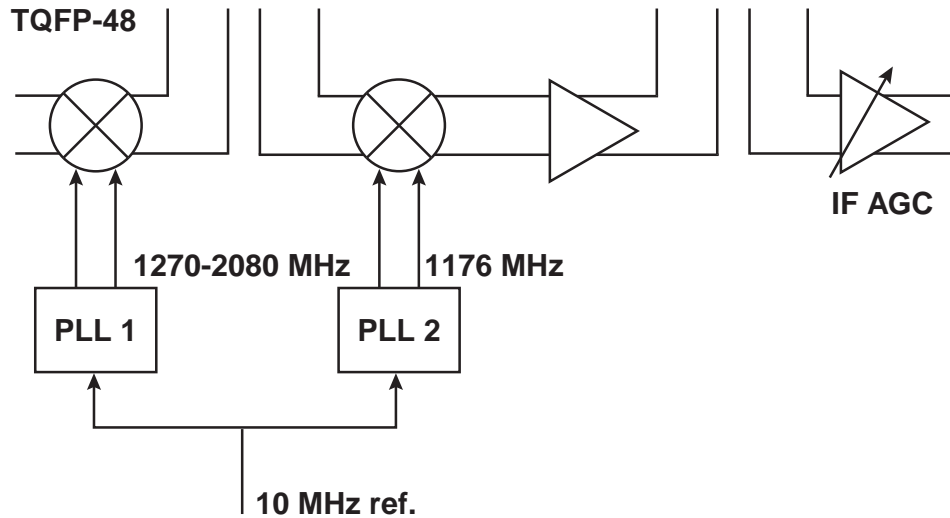

### Overview

The BCM3416 is a highly integrated silicon tuner. The BCM3401, containing an LNA and the RF AGC, is the companion part to the BCM3416. This two-chip solution supports both 64-QAM and 256-QAM digital cable modem applications.

The BCM3416 and BCM3401 are specifically designed to work with Broadcom's industry-leading BCM3345, BCM3360, BCM3348, and BCM3250 single-chip cable modems, and form an attractive alternative to traditional can tuners in any cable modem design.

The BCM3416 supports an IF output frequency range of 36 MHz through 44 MHz and specifically supports the 36.125 MHz and 43.75 MHz center frequencies for the PAL and NTSC standards. Also, the BCM3416 and BCM3401 chipsets are DOCSIS and EuroDOCSIS-based.

Great care was taken to develop the proven reference designs, which also minimize the external components required. This system's expertise allows our customers to design with confidence even if they have minimal in-house RF expertise, while lowering their overall BOM cost versus the traditional can tuners.

### Technical Brief

The signal is passed from the BCM3401 to the up conversion mixer. The up conversion mixer translates the input up to a fixed first IF of 1220 MHz. The narrowband first IF eliminates processing of unnecessary channels.

The down conversion mixer brings the signal down to the output IF of 43.75 MHz (or 36.125 MHz for PAL). The IF amplifier buffers the differential output signal that can directly drive an external SAW filter, where the final channel selection filtering occurs.

The IF AGC amplifies the signal returned from the SAW filter over a 30-dB range and buffers the differential output signal. The signal is then appropriately biased to the input of the BCM3345, BCM3360, BCM3348, and BCM3250.

A two-wire MBus-compatible serial bus controls the chip.

Broadcom®, the pulse logo, and Connecting everything® are trademarks of Broadcom Corporation and/or its subsidiaries in the United States and certain other countries. All other trademarks mentioned are the property of their respective owners.

Connecting  
everything®



**BROADCOM CORPORATION**  
16215 Alton Parkway, P.O. Box 57013  
Irvine, California 92619-7013

© 2003 by BROADCOM CORPORATION. All rights reserved.

3416-PB04-R 09/04/03

Phone: 949-450-8700  
Fax: 949-450-8710  
E-mail: [info@broadcom.com](mailto:info@broadcom.com)  
Web: [www.broadcom.com](http://www.broadcom.com)