



# BCM7021 PRODUCT Brief



## HIGH-DEFINITION VIDEO PCI SUBSYSTEM WITH 2D GRAPHICS

### FEATURES

- **ATSC-compliant, All-Format MP@HL MPEG-2 video decoder**
  - Decodes up to four MP@ML video streams
  - Standard-definition output with reduced memory requirements
  - Simultaneous analog high-definition/standard-definition output
- **Dolby Digital (AC-3)/MPEG multichannel audio decoder with SPDIF output**
  - Dual I<sup>2</sup>S bidirectional audio ports
- **Stereo audio DACs**
- **Advanced 2D/3D-effects graphics engine**
  - Studio-quality text and graphics at HD resolution
  - Supports multiple layers and windows
- **NTSC analog video decoder**
- **NTSC/PAL/HD video encoder**
- **PCI 2.1 compliant**
- **POD support including DVS 213 DES descrambler**
- **DVB and DC2-compliant transport demux with DVB and DES descramblers**
- **Simultaneous CCIR-656 inputs and outputs**
- **Support for PIDs and 64 section filters**

### SUMMARY OF BENEFITS

- **Provides a cost-effective solution for high-definition and standard-definition video and graphics systems common to cable and satellite applications.**
  - Includes standard definition with reduced memory mode
- **Simultaneous high-definition and standard-definition analog output for watch and record capability.**
- **Advanced 2D graphics system allows applications such as internet browsers and electronic program guides to deliver studio-quality text and graphics on television monitors**
- **3D effects create studio-quality screen transitions and add a whole new dimension to electronic program guides.**
- **Personal video recorder capability supports VCR-like functions via a hard disk.**
- **High-performance DMA capability can be used for cable modem traffic**
- **Broadcom-developed device drivers enable rapid software development cycle**
- **Supports DVS POD requirements**
- **PCI interface provides bi-endian support and up to 3 bus masters for maximum system design flexibility.**
- **PCI interface allows for direct connection of cost-effective SuperI/O devices**

### BCM7021 Advanced Video, Graphics, and Audio Subsystem

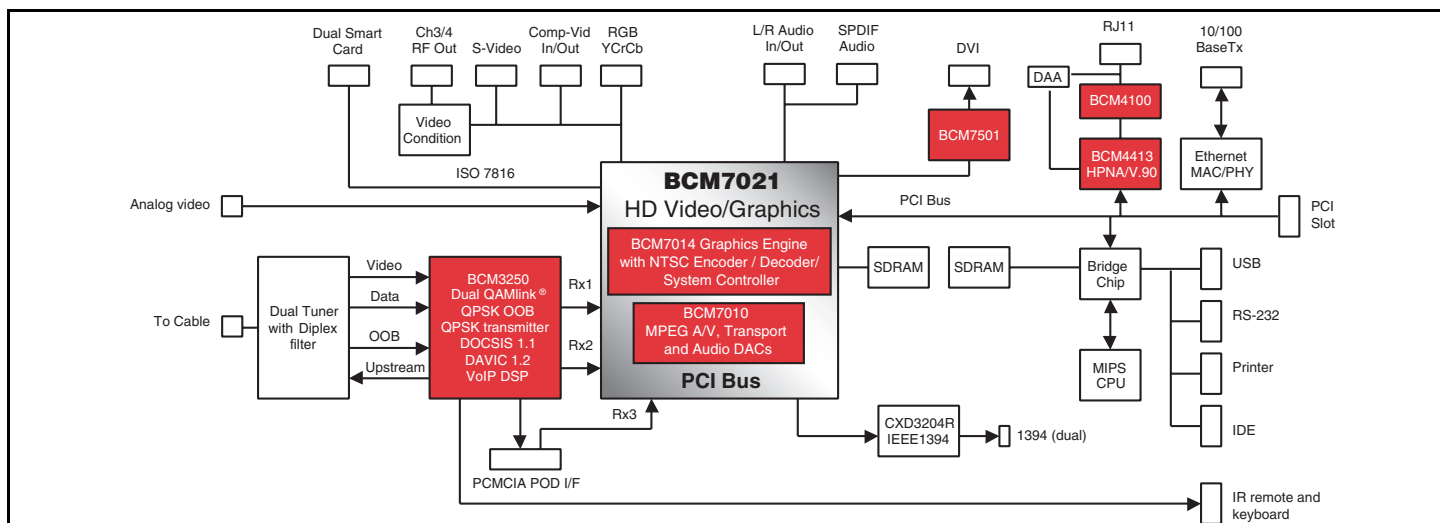

## OVERVIEW

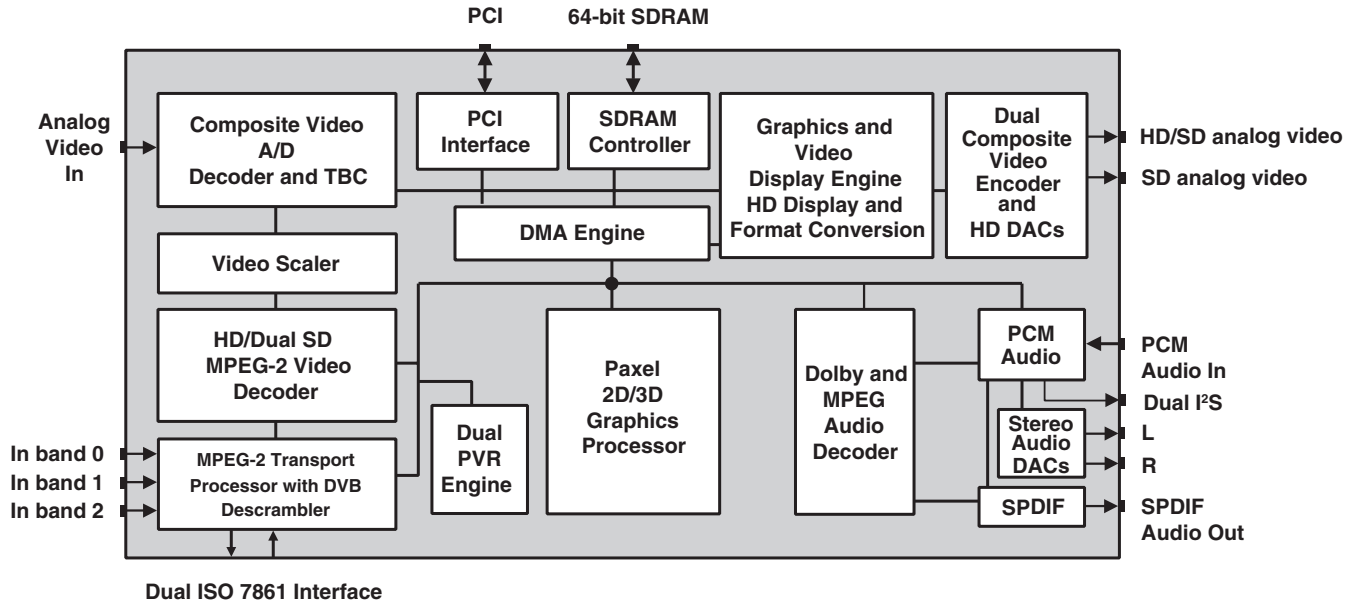

The BCM7021 Advanced High-Definition Video and Graphics Subsystem supports the requirements of television and set-top box systems that require high-definition or standard-definition decoding of MPEG-2 streams with simultaneous high-definition and standard-definition outputs. For systems that require only standard-definition output, a reduced-memory mode substantially reduces the amount of memory needed for the video decompressions process. The video decoder also supports multiple stream standard-definition decoding, providing both tiled video and PIP capability.

The BCM7021 graphics are based on Broadcom's advanced video/graphics technology that allows studio-quality text and graphics to be displayed on television-based systems. The graphics compositing engine allows for many windows of graphics and video to be layered with blending and antialiasing, creating high-quality, rich display capability.

An on-board vector RISC processor provides 2D graphics, antialiased text, and 3D effects.

A MPEG-2 DVB/DC2-compliant transport demux with three transport stream inputs has advanced section filtering capability, DVB descrambler, DES descrambler with ECB/CCB capability, and two ISO7816 smart card interfaces. The DES descrambler is compliant with the DVS 213 requirements for the transport stream POD interface.

The transport engine is designed to support personal video recorder (PVR) functions, allowing the set-top box to support VCR-like functions, such as fast forward/reverse, pause, and record. The BCM7021 supports up to 2 record and 2 playback streams simultaneously.

The BCM7021 decodes both Dolby Digital (AC-3) and MPEG multichannel compressed streams. Audio output is provided over stereo DACs or SPDIF.

A PCM audio engine mixes separate audio streams generated from the MPEG2/Dolby audio decompression circuitry, PCM audio generated from the CPU, or PCM audio input via a baseband audio input. These streams can be resampled and mixed together with volume control.

The BCM7021 is an ideal solution where maximum system design flexibility and performance is key. Its bi-endian architecture and full DMA capability work with any CPU and PCI system configuration.

Broadcom®, the pulse logo, and Connecting everything® are trademarks of Broadcom Corporation and/or its subsidiaries in the United States and certain other countries. All other trademarks mentioned are the property of their respective owners.

Connecting  
everything®



**BROADCOM CORPORATION**  
16215 Alton Parkway, P.O. Box 57013  
Irvine, California 92619-7013

© 2004 by BROADCOM CORPORATION. All rights reserved.

7021-PB03-R 07/06/04

Phone: 949-450-8700  
Fax: 949-450-8710  
E-mail: info@broadcom.com  
Web: www.broadcom.com