

STRUCTURE Silicon Monolithic Integrated Circuit
 TYPE Multiple Voltage Regulator For Car Audio
 PRODUCT SERIES **BD9401FM**
 FEATURES Built in Switching Regulator Controller, 1A Linear Regulator,
 and 500mA High-side Switch.

• ABSOLUTE MAXIMUM RATINGS ($T_A=25^\circ\text{C}$)

PARAMETER	SYMBOL	LIMIT	UNIT
Supply Voltage	VCC	36	V
Supply Voltage 2	VLDOIN	12 ^{*1}	V
Supply Voltage 3 (VREG, VREF)	VREG, VREF	7	V
PWM Output Current	IOMAX	100	mA
Power Dissipation 1	P_{D1}	1.8 ^{*2}	W
Power Dissipation 2	P_{D2}	2.2 ^{*3}	W
Operation Temperature Range	T_{OPR}	-40~+85	°C
Storage Temperature Range	T_{STG}	+150	°C
Junction temperature range	T_{JMAX}	+150	°C

*1 Do not exceed P_D .

*2 P_D decreased at 14.4mW/°C for temperatures above $T_A=25^\circ\text{C}$ without a heat sink.

*3 P_D decreased at 17.6mW/°C for temperatures above $T_A=25^\circ\text{C}$ with PCB (70×70×1.6mm³).

• OPERATING CONDITIONS ($T_A=-40\sim+85^\circ\text{C}$, Do not exceed P_D)

PARAMETER	SYMBOL	MIN.	MAX.	UNIT
Supply Voltage 1	VCC	8	26	V
Supply Voltage 2	VLDOIN	3	11	V
Maximum Frequency (PWM Controller)	VCC	30	500	KHz

NOTE : This product is not designed for protection against radioactive rays.

NOTE : The product described in this specification is a strategic product (and/or service) subject to COCOM regulations.
 It should not be exported without authorization from the appropriate government.

Status of this document

The English version of this document is the formal specification.

A customer may use this translation version only for a reference to help reading the formal version.

If there are any differences in translation version of this document, formal version takes priority.

· ELECTRICAL CHARACTERISTIC 1

 (T_A=25°C, VCC=13.5V, VDOVCC=5V, HSOCTL=PWMCTL=3V unless otherwise specified.)

PARAMETER	SYMBOL	STANDARD VALUE			UNIT	CONDITIONS
		MIN.	TYP.	MAX.		
[Linear Regulator Adjustable 1.0A]						
Output Voltage	V _O	-	3.3	-	V	I _o =10mA
NF Voltage	V _{NF}	1.225	1.250	1.275	V	
Output Peak Current	I _{PEAKL}	1.0	-	-	A	without an external FET
Line regulation	ΔV _{OLI}	-	10	20	mV	VCC=9~26V
Load regulation	ΔV _{OLO}	-	50	100	mV	I _o =800mA
Dropout Voltage	ΔV _{DLDO}	-	0.5	1.0	V	I _o =800mA
Ripple Rejection	RR	50	60	-	dB	I _o =10mA, V _{IN} =0.1V _{p-p}
[High-side Switch 500mA]						
Dropout Voltage	V _{DH}	—	0.5	0.8	V	I _o =500mA
Output Peak Current	I _{PEAKH}	0.5	-	-	A	
[Error Amplification]						
INV Threshold Voltage	V _{INV}	1.225	1.250	1.275	V	VREF=3.0V
INPUT Bias Current	I _{BIAS}	-1	-	1	uA	V _{INV} =0V
Voltage Gain	A _V	-	60	-	dB	DC Gain
Maximum Output Voltage	V _{F_{BM}}	2.0	2.4	2.8	V	V _{INV} =0V
Minimum Output Voltage	V _{F_{BL}}	-	-	0.1	V	V _{INV} =2.0V
Output Sink Current	I _{F_{BSI}}	1	2.5	4	mA	V _{FB} =3V, V _{INV} =0V
Output Source Current	I _{F_{BSO}}	50	100	200	uA	V _{FB} =0V, V _{INV} =2V
[PWM Comparator]						
0% Duty Cycle	V _{TH0}	0.90	1.00	1.10	V	FB Voltage, OSCIN=1.0V
100% Duty Cycle	V _{TH100}	1.80	2.00	2.20	V	FB Voltage, OSCIN=2.0V
[Protection Circuit]						
Timer Start Voltage	V _{SINV}	0.8	0.9	1.0	V	INV Voltage
Stand-by Voltage	V _{S_{SCP}}	-	50	100	mV	SCP Voltage
Threshold Voltage 1	V _{T1SCP}	0.90	1.00	1.10	V	SCP Voltage, SCD_OUT: High
Threshold Voltage 2	V _{T2SCP}	1.80	2.00	2.20	V	SCP Voltage, PWM: OFF
Source Current	I _{S_{OSCP}}	1.5	2.5	4.0	uA	V _{SCP} =0V
[Under Voltage Lockout]						
Threshold Voltage	V _{UVLO}	-	5.70	-	V	PWM:OFF, VCC=13.5→4V
Hysteresis Voltage	V _{HYS}	-	0.07	-	V	VCC=4V→13.5V
[PNP DRIVER]						
Saturation Voltage	V _{SAT}	-	0.8	1.2	V	I _o =75mA
Output Current	V _{DET1}	-	-	5	uA	V _o =30V
[Control Input]						
PWM Off Input Range	V _{PWMOFF}	0.0	-	2.0	V	
PWM On Input Range	V _{PWMON}	3.0	-	VREG	V	
HSDSW Off Input Range	V _{HSDOFF}	0.0	-	2.0	V	
HSDSW On Input Range	V _{HSDON}	3.0	-	VREG	V	
[SCD OUTPUT]						
SCD Low Voltage Range	V _{SCDL}	0.0	-	1.0	V	
SCD High Voltage Range	V _{SCDH}	3.0	-	VREG	V	
[All Devices]						
Consumption Current VCC	I _{CC}	-	1.65	3.2	mA	D_CTL=H_CTL=3V, I _o =0mA
Consumption Current VREG	I _{VREG}	-	1.30	-	mA	VREG=5.0V
Consumption Current VREF	I _{VREF}	-	0.65	-	mA	VREF=3.0V
Stand-by Current	I _{STBY}	-	1	10	μA	D_CTL=H_CTL=0V

○Physical Dimensions

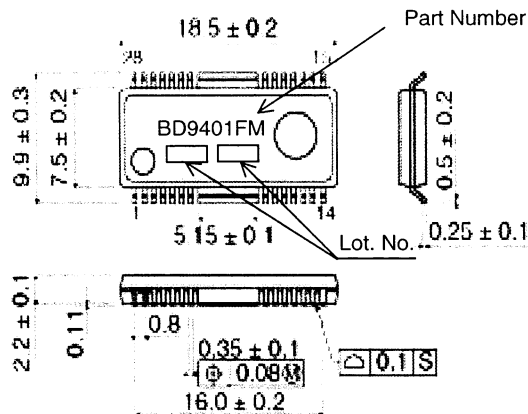

○Block Diagram

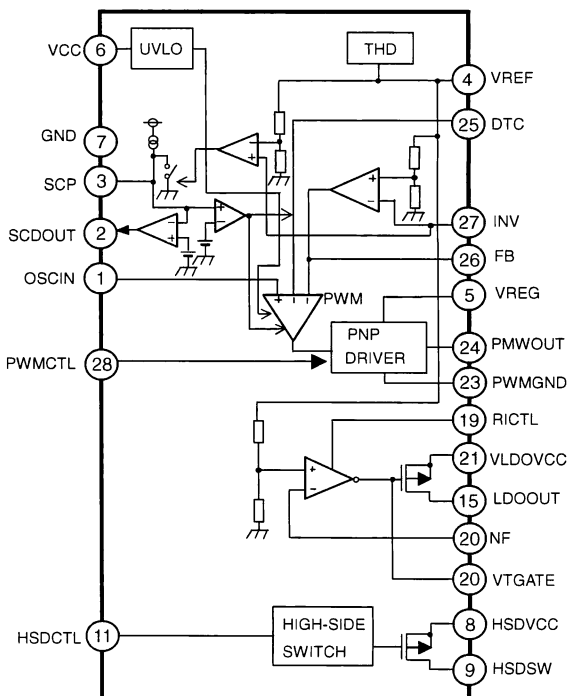

• PIN FUNCTION

No.	PIN NAME	FUNCTION	No.	PIN NAME	FUNCTION
1	OSCIN	Triangle oscillator input from BD9400BFP	16	N.C.	Non connection
2	SCDOUT	DC/DC short circuit detection signal output to BD9400BFP	17	N.C.	Non connection
3	SCP	Adjustment of short circuit protection and detection with capacitor	18	VTGATE	Be connected GATE of external FET
4	VREF	Reference voltage (3V) from BD9400BFP	19	RICTL	Adjustment of current limit for LDO
5	VREG	Reference voltage (5V) from BD9400BFP	20	NF	Negative feedback input pin of LDO
6	VCC	Main power supply pin	21	LDOVCC	Power supply pin for LDO
7	GND	Low-noise ground	22	N.C.	Non connection
8	HSDVCC	Power supply pin for High-side switch	23	PWMGND	PWM ground
9	HSDSW	High-side switch output	24	PWMOUT	PWM Output terminal
10	N.C.	Non connection	25	DTC	Dead Time Control PIN with resistor (adjustment of Soft Start)
11	HSDCTL	High-side switch enable/disable control input from BD9401FM	26	FB	Output terminal of err amplifier
12	N.C.	Non connection	27	INV	Inverting input terminal of err amplifier
13	N.C.	Non connection	28	PWMCTL	DC/DC converter enable/disable control input from BD9400BFP
14	N.C.	Non connection	FIN	FIN	It should be connected ground
15	LDOOUT	LDO output			

※ Please refer to technical note concerning application circuit and etc.

○ NOTE FOR USE

1. **Absolute Maximum Range**
Absolute Maximum Ratings are values stated values, when any values in excess stated values may cause the device to be destroyed.
We cannot be defined the failure mode, such as short mode or open mode.
Therefore, physical devices for protection, such as fuses to be provided when a specific mode exceeds the Absolute.
2. **Operating Supply Voltage Range**
Functional circuit operation is guaranteed within operation ambient temperature, as long as it is within operating supply voltage range. The electrical characteristics standard value can not be guaranteed. However, there is no drastic variation in these values, as long as it is within operating supply voltage range.
3. **Grounding**
Connection of GND indicated in application circuit should be as short as possible to avoid electrical interference.
4. **Power dissipation**
If IC is used on condition that the power loss is over the power dissipation, the reliability will become worse by heat up, such as reduced output current capability.
Also, be sure to use this IC within a power dissipation range allowing enough of margin.
5. **Oscillation Stopper of Output and Bypass Capacitor**
Please put capacitor of $10\ \mu\text{F}$ on LDOOUT respectively to stop oscillation. It has a possibility of oscillation if capacitor value is changed due to temperature change. And it is recommended to use tantalum or electrolytic capacitor with low internal serial resistor (ESR). If extremely big capacitor (over $1000\ \mu\text{F}$) is used, it may have a case to occur oscillation of low frequency. And it is recommended to put bypass capacitor $1\ \mu\text{F}$ into the nearest position between Input pin and GND.
6. **Electrical characteristics described in these specifications may vary, depending on temperature, supply voltage, external circuits and other conditions. Therefore, be sure to check all relevant factors, including transient characteristics.**
7. **Overcurrent protection circuit**
The built-in overcurrent protection circuit is designed to respond to the output current and prevent destruction of the IC from load short circuits; however, it is only effective in protecting the IC from destruction in sudden overcurrent accidents. The protection circuit is not to be used continuously, or for transitions. In executing thermal design, bear in mind that overcurrent protection has negative characteristic according with the temperature.
8. **Thermal shutdown circuit**
A built-in internal shutdown (TSD) circuit is provided to protect the IC from heat destruction. Operation has to be done within the allowable loss range, but in continuous use beyond the range, chip temperature T_j will increase to the threshold, activating the TSD circuit and turning the output power Tr OFF. Once the chip temperature T_j returns to the normal range, the circuit is automatically restored. Note that the TSD circuit is designed to operate over the maximum absolute rating. Therefore, make absolutely certain not to use the TSD function in set design.
9. **Mounting Failures**
Mounting failure, such as misdirection or mismount, may cause a malfunction in the device.
10. **Internal circuits or elements may be damaged when Vcc and pin voltage are reversed. For example, Vcc short circuit to GND while a external capacitor is charged. Output pin capacitor is recommended no larger than $1000\ \mu\text{F}$. In addition, inserting a Vcc series countercurrent prevention diode, or a bypass diode between the various pins and the vcc, is recommended.**
11. **Electric Magnetic Field**
Mal-function may happen when the device is used in the strong electromagnetic field.
12. **We recommend to put diode for protection purpose in case of output pin connected with large load of impedance or reverse current occurred during start up or output off timing.**
13. **Precautions for board inspection**
Connecting low-impedance capacitors to run inspections with the board may produce stress on the IC. Therefore, be certain to use proper discharge procedure before each process of the test operation. To prevent electrostatic accumulation and discharge in the assembly process, thoroughly ground yourself and any equipment that could sustain ESD damage, and continue observing ESD-prevention procedures in all handling, transfer and storage operations. Before attempting to connect components to the test setup, make certain that the power supply is OFF. Likewise, be sure the power supply is OFF before removing any component connected to the test setup.
14. **GND pattern**
When both a small-signal GND and high current GND are present, single-point grounding (at the set standard point) is recommended, in order to separate the small-signal and high current patterns, and to be sure the voltage change stemming from the wiring resistance and high current does not cause any voltage change in the small-signal GND. In the same way, care must be taken to avoid voltage fluctuations in any connected external component GND.

Notes

- No technical content pages of this document may be reproduced in any form or transmitted by any means without prior permission of ROHM CO.,LTD.
- The contents described herein are subject to change without notice. The specifications for the product described in this document are for reference only. Upon actual use, therefore, please request that specifications to be separately delivered.
- Application circuit diagrams and circuit constants contained herein are shown as examples of standard use and operation. Please pay careful attention to the peripheral conditions when designing circuits and deciding upon circuit constants in the set.
- Any data, including, but not limited to application circuit diagrams information, described herein are intended only as illustrations of such devices and not as the specifications for such devices. ROHM CO.,LTD. disclaims any warranty that any use of such devices shall be free from infringement of any third party's intellectual property rights or other proprietary rights, and further, assumes no liability of whatsoever nature in the event of any such infringement, or arising from or connected with or related to the use of such devices.
- Upon the sale of any such devices, other than for buyer's right to use such devices itself, resell or otherwise dispose of the same, no express or implied right or license to practice or commercially exploit any intellectual property rights or other proprietary rights owned or controlled by
- ROHM CO., LTD. is granted to any such buyer.
- Products listed in this document are no antiradiation design.

The products listed in this document are designed to be used with ordinary electronic equipment or devices (such as audio visual equipment, office-automation equipment, communications devices, electrical appliances and electronic toys).

Should you intend to use these products with equipment or devices which require an extremely high level of reliability and the malfunction of which would directly endanger human life (such as medical instruments, transportation equipment, aerospace machinery, nuclear-reactor controllers, fuel controllers and other safety devices), please be sure to consult with our sales representative in advance.

About Export Control Order in Japan

Products described herein are the objects of controlled goods in Annex 1 (Item 16) of Export Trade Control Order in Japan.

In case of export from Japan, please confirm if it applies to "objective" criteria or an "informed" (by MITI clause) on the basis of "catch all controls for Non-Proliferation of Weapons of Mass Destruction.

Thank you for your accessing to ROHM product informations.
More detail product informations and catalogs are available,
please contact your nearest sales office.

Please contact our sales offices for details ;

U.S.A / San Diego	TEL : +1(858)625-3630	FAX : +1(858)625-3670
Atlanta	TEL : +1(770)754-5972	FAX : +1(770)754-0691
Dallas	TEL : +1(972)312-8818	FAX : +1(972)312-0330
Germany / Dusseldorf	TEL : +49(2154)9210	FAX : +49(2154)921400
United Kingdom / London	TEL : +44(1)908-282-666	FAX : +44(1)908-282-528
France / Paris	TEL : +33(0)1 56 97 30 60	FAX : +33(0) 1 56 97 30 80
China / Hong Kong	TEL : +852(2)740-6262	FAX : +852(2)375-8971
Shanghai	TEL : +86(21)6279-2727	FAX : +86(21)6247-2066
Dilian	TEL : +86(411)8230-8549	FAX : +86(411)8230-8537
Beijing	TEL : +86(10)8525-2483	FAX : +86(10)8525-2489
Taiwan / Taipei	TEL : +866(2)2500-6956	FAX : +866(2)2503-2869
Korea / Seoul	TEL : +82(2)8182-700	FAX : +82(2)8182-715
Singapore	TEL : +65-6332-2322	FAX : +65-6332-5662
Malaysia / Kuala Lumpur	TEL : +60(3)7958-8355	FAX : +60(3)7958-8377
Philippines / Manila	TEL : +63(2)807-6872	FAX : +63(2)809-1422
Thailand / Bangkok	TEL : +66(2)254-4890	FAX : +66(2)256-6334

Japan /
(Internal Sales)

Tokyo	2-1-1, Yaesu, Chuo-ku, Tokyo 104-0082	TEL : +81(3)5203-0321	FAX : +81(3)5203-0300
Yokohama	2-4-8, Shin Yokohama, Kohoku-ku, Yokohama, Kanagawa 222-8575	TEL : +81(45)476-2131	FAX : +81(45)476-2128
Nagoya	Dainagayo Building 9F 3-28-12, Meieki, Nakamura-ku, Nagoya, Aichi 450-0002	TEL : +81(52)581-8521	FAX : +81(52)561-2173
Kyoto	579-32 Higashi Shiokouji-cho, Karasuma Nishi-iru, Shiokoujidori, Shimogyo-ku, Kyoto 600-8216	TEL : +81(75)311-2121	FAX : +81(75)314-6559

(Contact address for overseas customers in Japan)

Yokohama	TEL : +81(45)476-9270	FAX : +81(045)476-9271
----------	-----------------------	------------------------